

Prüfbericht Nr. / Test Report No.

**202458306**

UN Regelung Nr. 159 / UN Regulation No. 159



Typ / Type : **R159 Front Radar**

Hersteller / Manufacturer : **Autel**

---

## **Prüfbericht Test Report**

In Anlehnung an

*following to the Regulation*

**Einheitliche Bedingungen für die Genehmigung von Kraftfahrzeugen hinsichtlich  
des Anfahrinformationssystems zur Erkennung von Fußgängern und Fahrradfah-  
rern**

***Uniform provisions concerning the approval of motor vehicles with regard to the  
Moving Off Information System for the Detection of Pedestrians and Cyclists***

**UN Regelung Nr. 159 / UN Regulation No. 159**

vom / dated **10.06.2021**

zuletzt geändert durch / last amended by

**Ergänzung / Supplement 2**

vom / dated **05.06.2022**

Typ / Type : **R159 Front Radar**  
 Hersteller / Manufacturer : **Autel**

---

Die folgende Nummerierung in Klammern entspricht der UN Regelung Nr. 159  
 The following numbering in brackets corresponds to the UN Regulation no. 159

0	Grund der Erweiterung <i>Reason for extension</i>	: entfällt <i>not applicable</i>
<b>I</b>	<b>Allgemeines</b> <b>General</b>	
1	Fabrikmarke (Firmenname des Herstellers) <i>Trade name (trade name of the manufacturer)</i>	: Autel
2	Typ <i>Type</i>	: R159 Front Radar
3	Varianten <i>Variants</i>	-
4	Handelsname(n) und Version(en) <i>Commercial name(s) and version(s)</i>	: R159 Front Radar
5	Fahrzeugklasse <i>Category of vehicle</i>	: entfällt <i>not applicable</i>
6	Name und Anschrift des Herstellers <i>Manufacturer's name and address</i>	: Auteradar Europe UG Forststr. 13A 86576 Schiltberg
7	Name(n) und Anschrift(en) der Fertigungsstätte(n) <i>Name(s) and adress(es) of assembly plant(s)</i>	: entfällt <i>not applicable</i>
8	(ggf.) Name und Anschrift des Bevollmächtigten des Herstellers <i>Name and address of the manufacturer's representative (if any)</i>	: entfällt <i>not applicable</i>
9	Nr. des Beschreibungsbogens <i>No. of Information Document</i>	: entfällt <i>not applicable</i>
9.1	Ausgabedatum <i>Date</i>	: entfällt <i>not applicable</i>
9.2	Änderungsstand <i>Revision status</i>	: nicht zutreffend <i>not applicable</i>

Typ / Type : **R159 Front Radar**  
 Hersteller / Manufacturer : **Autel**

**II Systembeschreibung**  
**System Description**

**10 Allgemeine Beschreibung**  
**General description**

Bei dem AUTEL R159 Anfahrinformati-  
 onssystem handelt es sich um ein Radarbasier-  
 tes System, dass ungeschützte Verkehrsteil-  
 nehmer im Frontbereich bei Anfahrsituati-  
 onen erfasst und dem Fahrer signalisiert.

Das System besteht aus den Komponenten  
 Frontradar, GPS/IMU Einheit und einer An-  
 zeigeeinheit.

Das System detektiert und zeigt dem Fahrer  
 Objekte im Frontbereich des Fahrzeuges an.  
 Dabei beträgt der Erfassungsbereich  
 4,2mx4,2m bei einem Erfassungswinkel von  
 180°.

Die Anzeigeeinheit ist aufteilt in 3 Segmente,  
 die jeweils 3 Farben darstellen können.

Die 3 Segmente stellen die Position des er-  
 fassten Objektes im Erfassungsbereich dar.  
 Über die farbliche Unterscheidung grün-gelb  
 und rot ist der Abstand zum Objekt erkenn-  
 bar.

*The AUTEL R159 collision information sys-  
 tem is a radar-based system that detects vul-  
 nerable road users in the front area in colli-  
 sion situations and signals them to the  
 driver.*

*The system consists of the components front  
 radar, GPS/IMU unit and a display unit.*

*The system detects and displays objects in  
 the front area of the vehicle to the driver. The  
 detection area is 4.2m x 4.2m with a detec-  
 tion angle of 180°.*

*The display unit is divided into 3 segments,  
 each of which can display 3 colours.*

*The 3 segments represent the position of the  
 detected object in the detection area. The  
 distance to the object is indicated by the col-  
 our differentiation green-yellow and red.*

**11 Technische Daten**  
**Technical Data**

: Siehe Anlage 1-1 Punkt 1.1  
 See Annex 1- 1 item 1.1

**12 Informations- und Warnstrategie**  
**Information and warning strategie**

: Siehe Anlage 1-1 Punkt 1.2  
 See Annex 1-1 item 1.2

**13 Kalibrier- und Einlernstrategie**  
**Calibration- and learning strategie**

: Siehe Anlage 1-1 Punkt 2  
 See Annex 1-1 item 2

**14 Verhalten im Fehlerfall**  
**Behaviour in the event of an error**

: Siehe Anlage 1-1 Punkt 1.2  
 See Annex 1-1 item 1.2

Typ / Type : **R159 Front Radar**

Hersteller / Manufacturer : **Autel**

---

15	Systemgrenzen <i>System limitations</i>	: Siehe Anlage 1-1 Punkt 1 <i>See Annex 1-1 item 1</i>
16	Wartung <i>Maintenance</i>	: Siehe Anlage 1-1 Punkt 2 <i>See Annex 1-1 item 2</i>
17	Anbauposition <i>Place of installation</i>	: Siehe Anlage 1-1 Punkt 2 <i>See Annex 1-1 item 2</i>
18	Voraussetzungen <i>Requirements</i>	: entfällt <i>not applicable</i>
19	Kennzeichnung <i>Marking</i>	: Siehe Anlage 1-5 <i>See Annex 1-5</i>
20	Verwendungsbereich <i>Field of application</i>	: NFZ Klasse N2 und N3 sowie Kraftomni- busse (M2 & M3) mit mehr als 9 Sitzplätzen einschließlich Fahrerplatz, welche den fol- genden Einbaubedingungen gerecht wer- den. Das System muss komplett an dem Fahrzeug verbaut sein, in dem der Fahrer die Warnung erhält.

Typ / Type : **R159 Front Radar**Hersteller / Manufacturer : **Autel**

<b>III</b>	<b>Prüfprotokoll</b> <b>Test record</b>	
	<b>Prüffahrzeug</b> <b>Test vehicle</b>	
1	Hersteller <i>Manufacturer</i>	: Iveco
2	Typ <i>Type</i>	: IG80EL2BA
3	Handelsbezeichnung <i>Commercial name</i>	: Eurocargo 75-210
4	Fahrzeug Kategorie <i>Vehicle categorie</i>	: N2
		<p>Hinsichtlich der Anforderungen an die Tests bzgl. der Anforderungen kann das verwendete N2 Fahrzeug für die Fahrzeuge des Verwendungsbereichs dienen.</p> <p><i>With regard to the test requirements, the N2 vehicle used can serve for the vehicles in the field of application.</i></p>
5	Fahrzeug-Ident-Nr. <i>VIN</i>	: ZCFA875F902711826
6	Prüfmasse gesamt (unbeladen) <i>Testing mass unloaden</i>	: 5060 kg
7	Ausstattung <i>Equipment</i>	: -
7.1	Softwarestand Steuergerät <i>Softwareversion ECU</i>	: ASR102_FR_APP_V1.1.1.4.rcl
7.2	Anbauposition Sensor(en) <i>Place of installation for sensor(s)</i>	: Gemäß Anlage 1-1 in Verbindung mit ungünstigstem Fall <i>according Annex 1-1 in connection with worst case</i> Durch die relativ horizontale Erfassungsfläche stellt die höchst mögliche Verbauposition den ungünstigsten Fall dar. <i>Due to the nearly horizontal detection area, the highest possible shoring position represents the most unfavourable case.</i>
8	Bemerkungen <i>Remarks</i>	: -
9	Prüfdatum <i>Date of test</i>	: 24.05.2024

Typ / Type : **R159 Front Radar**  
 Hersteller / Manufacturer : **Autel**

10 Prüfort : DEKRA Automobil Test Center, Klettwitz  
*Place of test*

11 Wetterbedingungen : Trocken, wolzig  
*Weather conditions Dry, cloudy*

**2. Prüfergebnisse**  
**Test results**

**2.1 (5.1.) Allgemeine Anforderungen**  
**General requirements**

2.1.1 (5.1.1) Die Anforderungen des Punktes 5.2.2. der Regelung werden erfüllt. :  Ja/Yes  
*The requirements of point 5.2.2. of the regulation are met.*  Nein/No

2.1.2 (5.1.2) Die Wirksamkeit des Anfahrinformationssystem wird nicht durch magnetische oder elektrische Felder beeinträchtigt werden. :  Ja/Yes  
*The effectiveness of the MOIS is not be adversely affected by magnetic or electrical fields.*  Nein/No

Genehmigung nach UN Regelung Nr. 10 : Radar ASR100:  
*Approval acc. UN Regulation no. 10* E13\*10R06/02\*16316\*00  
 Display MOIS DSP 00:  
 E24\*10R06/02\*5467\*00  
 GPS/IMU ASI100:  
 E24\*10R06/01\*4187\*00

**2.2 (5.2.) Leistungsanforderungen**  
**Performance requirements**

2.2.1 (5.2.1) Die Anforderungen des Punktes 5.2.1. der Regelung werden erfüllt. :  Ja/Yes  
*The requirements of point 5.2.1. of the regulation are met.*  Nein/No

Bemerkung : Als Radar-basiertes System ist es unabhängig von der Umgebungshelligkeit  
*Remark Radar System independent from ambient light*

(5.2.2.) Die Anforderungen des Punktes 5.2.2. der Regelung werden erfüllt. :  Ja/Yes  
*The requirements of point 5.2.2. of the regulation are met.*  Nein/No

Typ / Type : **R159 Front Radar**

Hersteller / Manufacturer : **Autel**

- (5.2.2.1) Die Anforderungen des Punktes 5.2.2.1. der Regelung werden erfüllt.  
*The requirements of point 5.2.2.1. of the regulation are met.* :  Ja/Yes  
 Nein/No
- (5.2.2.2. 1) Die Anforderungen des Punktes 5.2.2.2.1. der Regelung werden erfüllt.  
*The requirements of point 5.2.2.2.1. of the regulation are met.* :  Ja/Yes  
 Nein/No
- (5.2.2.3. 1) Die Anforderungen des Punktes 5.2.2.3.1. der Regelung werden erfüllt.  
*The requirements of point 5.2.2.3.1. of the regulation are met.* :  Ja/Yes  
 Nein/No
- (5.2.2.3. 2) Die Anforderungen des Punktes 5.2.2.3.2. der Regelung werden erfüllt.  
*The requirements of point 5.2.2.3.2. of the regulation are met.* :  Ja/Yes  
 Nein/No
- (5.2.2.3. 3) Die Anforderungen des Punktes 5.2.2.3.3. der Regelung werden erfüllt.  
*The requirements of point 5.2.2.3.3. of the regulation are met.* :  Ja/Yes  
 Nein/No  
Nicht zutreffend  
*Not applicable*
- 2.2.6 (5.2.2.4) Informationssignal entspricht den Anforderungen in Absatz 5.6 der Regelung  
*Information signal complies with the requirements in item 5.6 of the regulation* :  Ja/Yes  
 Nein/No
- (5.2.3) Die Anforderungen des Punktes 5.2.3. der Regelung werden erfüllt.  
*The requirements of point 5.2.3. of the regulation are met.* :  Ja/Yes  
 Nein/No
- 2.2.7 (5.3.1) Die Anforderungen des Punktes 5.3.1 der Regelung werden erfüllt.  
*The requirements of point 5.3.1 of the regulation are met.* :  Ja/Yes  
 Nein/No
- (5.3.2) Die Anforderungen des Punktes 5.3.2 der Regelung werden erfüllt.  
*The requirements of point 5.3.2 of the regulation are met.* :  Ja/Yes  
 Nein/No
- (5.3.3) Die Anforderungen des Punktes 5.3.3 der Regelung werden erfüllt.  
*The requirements of point 5.3.3 of the regulation are met.* :  Ja/Yes  
 Nein/No

Typ / Type : **R159 Front Radar**

Hersteller / Manufacturer : **Autel**

- |       |              |   |  |
|-------|--------------|---|--|
| 2.2.8 | (5.4.1)      | Die Anforderungen des Punktes 5.4.1 der Regelung werden erfüllt.<br><i>The requirements of point 5.4.1 of the regulation are met.</i>     | : <input type="checkbox"/> Ja/Yes<br><input type="checkbox"/> Nein/No<br><br>Nicht zutreffend<br><i>Not applicable</i> |
|       | (5.4.2)      | Die Anforderungen des Punktes 5.4.2 der Regelung werden erfüllt.<br><i>The requirements of point 5.4.2 of the regulation are met.</i>     | : <input type="checkbox"/> Ja/Yes<br><input type="checkbox"/> Nein/No<br><br>Nicht zutreffend<br><i>Not applicable</i> |
|       | (5.4.3)      | Die Anforderungen des Punktes 5.4.3 der Regelung werden erfüllt.<br><i>The requirements of point 5.4.3 of the regulation are met.</i>     | : <input type="checkbox"/> Ja/Yes<br><input type="checkbox"/> Nein/No<br><br>Nicht zutreffend<br><i>Not applicable</i> |
|       | (5.4.4)      | Die Anforderungen des Punktes 5.4.4 der Regelung werden erfüllt.<br><i>The requirements of point 5.4.4 of the regulation are met.</i>     | : <input type="checkbox"/> Ja/Yes<br><input type="checkbox"/> Nein/No<br><br>Nicht zutreffend<br><i>Not applicable</i> |
|       | (5.4.5)      | Die Anforderungen des Punktes 5.4.5 der Regelung werden erfüllt.<br><i>The requirements of point 5.4.5 of the regulation are met.</i>     | : <input type="checkbox"/> Ja/Yes<br><input type="checkbox"/> Nein/No<br><br>Nicht zutreffend<br><i>Not applicable</i> |
|       |              | Bemerkungen<br><i>Remarks</i>   | : Kein manuelle Abschaltung vorgesehen<br><i>No manual deactivation possible</i>                                       |
| 2.2.9 | (5.5.1)      | Die Anforderungen des Punktes 5.5.1 der Regelung werden erfüllt.<br><i>The requirements of point 5.5.1 of the regulation are met.</i>     | : <input checked="" type="checkbox"/> Ja/Yes<br><input type="checkbox"/> Nein/No                                       |
| 2.3.  | <b>(5.6)</b> | <b>Informationssignal</b><br><b><i>Information Signal</i></b>   |  |
| 2.3.1 | (5.6.1)      | Informationssignal entspricht den Anforderungen in Punkt 5.6.1<br><i>Information signal complies with the requirements in point 5.6.1</i> | : <input checked="" type="checkbox"/> Ja/Yes<br><input type="checkbox"/> Nein/No                                       |
| 2.3.2 | (5.6.2)      | Informationssignal entspricht den Anforderungen in Punkt 5.6.2<br><i>Information signal complies with the requirements in point 5.6.2</i> | : <input checked="" type="checkbox"/> Ja/Yes<br><input type="checkbox"/> Nein/No                                       |

Typ / Type : **R159 Front Radar**

Hersteller / Manufacturer : **Autel**

**2.4. (5.7) Kollisionswarnsignal  
Collisionwarning Signal**

2.4.1 (5.7.1) Kollisionswarnsignal entspricht den Anforderungen in Punkt 5.7.1 :  Ja/Yes  
 Nein/No  
*Collisionwarning signal complies with the requirements in point 5.7.1*

2.4.2 (5.7.2) Kollisionswarnsignal entspricht den Anforderungen in Punkt 5.7.2 :  Ja/Yes  
 Nein/No  
*Collisionwarning signal complies with the requirements in point 5.7.2*

2.4.3 (5.7.3) Kollisionswarnsignal entspricht den Anforderungen in Punkt 5.7.3 :  Ja/Yes  
 Nein/No  
*Collisionwarning signal complies with the requirements in point 5.7.3*

2.4.4 (5.7.4) Kollisionswarnsignal entspricht den Anforderungen in Punkt 5.7.4 :  Ja/Yes  
 Nein/No  
*Collisionwarning signal complies with the requirements in point 5.7.4*

2.4.5 (5.7.5) Kollisionswarnsignal entspricht den Anforderungen in Punkt 5.7.5 :  Ja/Yes  
 Nein/No  
*Collisionwarning signal complies with the requirements in point 5.7.5*  
Nicht zutreffend  
*Not applicable*

Bemerkungen : Kein manuelle Abschaltung vorgesehen  
*Remarks No manual deactivation possible*

**2.5 (5.8) Fehlerwarnsignale  
Failure warning signals**

2.5.1 (5.8.1) Fehlerwarnsignal entspricht den Anforderungen in Punkt 5.8.1 :  Ja/Yes  
 Nein/No  
*Failure warning signal complies with the requirements in point 5.8.1*

2.5.2 (5.8.2) Fehlerwarnsignal erfüllt die Anforderungen in Punkt 5.8.2 :  Ja/Yes  
 Nein/No  
*Failure warning signal fulfils the requirements in point 5.8.2*

2.5.3 (5.8.3) Fehlerwarnsignal erfüllt die Anforderungen in Punkt 5.8.3 :  Ja/Yes  
 Nein/No  
*Failure warning signal fulfils the requirements in point 5.8.3*

Bemerkungen : Kein manuelle Abschaltung vorgesehen  
*Remarks No manual deactivation possible*

**2.6 (5.9) Vorschriften für die Überprüfung  
Provisions for inspection**

2.6.1 (5.9.1) Der korrekte Betriebszustand des An- :  Ja/Yes  
fahrinformationssystem kann durch op-  Nein/No  
tische Überprüfung des Status des  
Fehlerwarnsignals bestätigt werden.  
*It is possible to confirm the correct op-  
erational status of the MOIS by a visi-  
ble observation of the failure warning  
signal status.*

**3 Prüfverfahren  
Test procedure**

3.1 (6.1.) Die Anforderungen des Punktes :  Ja/Yes  
6.1.der Regelung werden erfüllt.  Nein/No  
*The requirements of point 6.1.of the  
regulation are met.*

**3.2 (6.2) Prüfbedingungen  
Test conditions**

3.2.1 (6.2.1) Anforderung Prüfstreckenoberfläche :  Ja/Yes  
erfüllt  Nein/No,  
*Requirements to test track surface ful-  
filled*

3.3 (6.2.2.) Anforderung an die Umgebungstem- :  Ja/Yes  
peratur erfüllt  Nein/No  
*Requirements to ambient temperature  
fulfilled*

3.4 (6.2.3) Anforderung an die Sichtverhältnisse :  Ja/Yes  
erfüllt  Nein/No  
*Requirements to visibility conditions  
fulfilled*

3.5 (6.2.4) Anforderung an die Umgebungsbe- :  Ja/Yes  
leuchtung erfüllt  Nein/No  
*Requirements to ambient lighting full-  
filled*  
Nicht zutreffend  
*Not applicable*

Bemerkung : Als Radar-basiertes System ist es unabhän-  
*Remark* : *gig von der Umgebungshelligkeit  
Radar System independent from ambient  
light*

3.6 (6.3) Fahrzeugbedingungen :  
*Vehicle conditions*

3.6.1 (6.3.1) Prüfungsgewicht : Siehe III.6  
*Test weight* *See Item III.6*

Typ / Type : **R159 Front Radar**Hersteller / Manufacturer : **Autel**

- 3.6.2 (6.3.2) Reifenluftdruck entspricht normalen Betriebsbedingungen  
*Tyre pressures for normal running conditions* :  Ja/Yes  
 Nein/No
- 3.6.3 (6.3.1) Das Anfahrinformationssystem wurde gemäß Punkt 6.3.1 der Regelung konditioniert  
*MOIS initialised according 6.3.1 of the regulation* :  Ja/Yes  
 Nein/No
- Bemerkung  
*Remark* : Keine Konditionierung nötig  
*No Pre-Test Conditioning necessary*
- 3.7 Prüf- und Messeinrichtung  
*Measuring- and testing equipment*
- Maßband  
*Measuring tape* : QS-Nr. 6645
- Fahrzeugwaage  
*Vehicle weight scale* : QS-Nr. 6759
- Detektor für audio-visuelle Signale  
*Detector for audio-visual signals* : QS-Nr. 7074
- Ferngesteuerte Plattform  
*Remote controlled platform* : QS-Nr. 7096
- Kreiselplattform 1  
*Gyro platform 1* : QS-Nr. 7092
- Kreiselplattform 2  
*Gyro platform 2* : QS-Nr. 7108
- Fahrradfahrer-Dummy  
*Bicycle dummy* : QS-Nr. 6976
- Personen-Dummy  
*Human Adult dummy* : QS-Nr. 7110
- Personen-Dummy  
*Human child dummy* : QS-Nr. 7097

Typ / Type : **R159 Front Radar**Hersteller / Manufacturer : **Autel**4 Bemerkungen : -  
Remarks**IV Anlagen  
Annexes**

Anlage / Annex	Nr. des Dokuments No. of document		Ausgabe stand State of issue	Datum Date	Sei- ten- zahl No. of pages
Grund der Erweiterung Reason for extension	Anlage 0 Annex 0	-	-	-	-
Systembeschreibung User Guide	Anlage 1-1 Annex 1-1	MOIS_R159_User Man- ual_Eng_V1.1	V1.1	17.06.2024	11
EMV Genehmigung Radar EMC Approval Sensor	Anlage 1-2 Annex 1-2	ASR_R10_Certificate_only	-	28.06.2022	9
EMV Genehmigung IMU&GPS EMC Approval IMU&GPS	Anlage 1-3 Annex 1-3	ASI100_R10_E24	-	21.10.2022	80
EMV Genehmigung Anzeige EMC Approval Display	Anlage 1-4 Annex 1-4	E-mark-E24 10R06 02 5467 00(1)	-	07.03.2024	33
Stückliste List of parts	Anlage 1-5 Annex 1-5	-	-	-	1

**IV Schlussbescheinigung  
Statement of conformity**

Dieser Prüfbericht gilt nur für das beschriebene Prüfobjekt.  
Das für diesen o.a. Typ repräsentative Prüfobjekt - e n t s p r i c h t - hinsichtlich der dokumentierten Prüfungen den Anforderungen der o. g. Prüfgrundlage.  
*This Test Report is only valid for the described test sample.  
The test sample representative for this type – c o m p l i e s – with the requirements of the above mentioned test specification with regard to the documented test method.*  
Die unter Nr. 9 angegebene Beschreibungsmappe und der darin beschriebene Typ - e n t s p r e c h e n - der o. a. Prüfspezifikation. Der ungünstigste Fall wurde entsprechend Punkt 7.2 dieses Prüfberichtes bestimmt.  
*The information folder as mentioned under No. 9 and the type described therein are - i n c o m p l i a n c e - with the Test Specification mentioned above. The worst case was selected as described in point 7.2 of this Test Report.*

Dieser Prüfbericht umfasst die Seiten 1 bis 13 und wird durch den Unterzeichner freigegeben.  
Eine auszugsweise Vervielfältigung und Veröffentlichung des Prüfberichtes ist nur nach schriftlicher Genehmigung des Prüflaboratoriums zulässig.  
*This report includes pages 1 to 13 and is approved by the signer.  
Duplication and publishing in extracts of the Test Report is allowed only by written permission of the Test Laboratory.*  
Das DEKRA Automobil Test Center ist ein durch die DAkkS nach DIN EN ISO/IEC 17025 akkreditiertes Prüflabor. Die Akkreditierung gilt nur für den in der Urkundenanlage D-PL-11060-01-00 aufgeführten Akkreditierungsumfang.  
*The DEKRA Automobil Test Center is a testing laboratory accredited by the DAkkS according to DIN EN ISO/IEC 17025. The accreditation is only valid for the scope of accreditation listed in the documente annex D-PL-11060-01-00.*

Klettwitz, 05.08.2024



Dipl.-Ing. (FH) Rayko Glowa  
Fachspezialist / Specialist

Tel.: 035754/7344 500 – Fax: 035754/7345 500 – e-mail: rayko.glowa@dekra.com

Ende des Prüfbericht.  
*End of Test Report.*

# Moving Off Information (R159) System User Guide

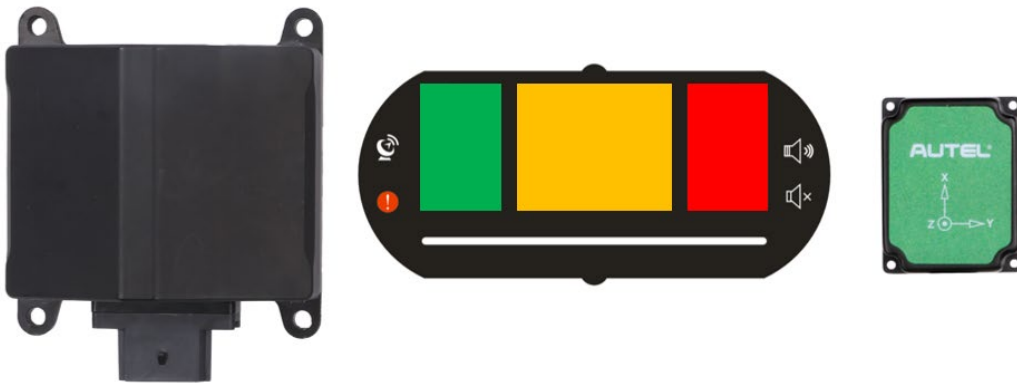

**R159 Front Radar – FR-001R159**

For technical support in all other markets please contact your local distributor.

## Table of contents

<b>1. Moving off Information System Description.....</b>	<b>3</b>
<b>1.1 ASR102 Radar Introduction .....</b>	<b>4</b>
<b>1.2 Warning display .....</b>	<b>5</b>
<b>1.3 GPS&amp;IMU module .....</b>	<b>8</b>
<b>1.4 System connections and the wiring harness .....</b>	<b>8</b>
<b>2. Installation Guide .....</b>	<b>9</b>
<b>2.1 Radar installation .....</b>	<b>9</b>
<b>2.2 Power Access .....</b>	<b>10</b>
<b>2.3 Installation of GPS and IMU module .....</b>	<b>10</b>

# 1. Moving off Information System Description

Moving off Information System is a smart radar-based detection system with precise target recognition and vehicle blind spot warnings. This system fulfills the MOIS UN ECE R159 safety requirements.

The system components are as follows: a millimeter wave radar with an operating frequency of 76-77GHz, a warning screen, a GPS and IMU module, and the cable. The millimeter wave radar can accurately measure object distance, speed, angle and other information through the difference in echoes between the transmitting and receiving electromagnetic waves. It is an all-weather and all-day blind spot warning assistant with a working temperature of -40°C - 85°C. The warning screen warns the driver of a dangerous object in the blind spot and reminds the driver to make timely adjustments on the road to avoid collisions.

The Moving off information system covers 180° on one side, no blind spots, with a target detection range of up to 4.2m x 4.2m.

*Note: The actual radar detection range is much more than 4.2m x 4.2m. For the MOIS application 4.2m x 4.2m is sufficient.*

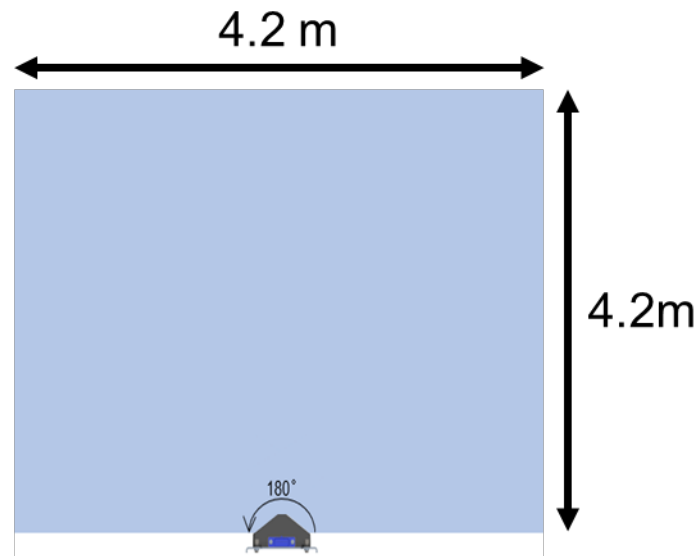

**Figure 1-1 ASR100 radar coverage**

## 1.1 ASR100 Radar Introduction

The ASR100 77 GHz millimeter wave radar is a compact, rugged radar sensor designed and manufactured by Autel Intelligence Vehicle® in China to warn heavy duty trucks/buses etc. of side blind spots with IP69K protection housing, in line with the environment for commercial vehicle use.

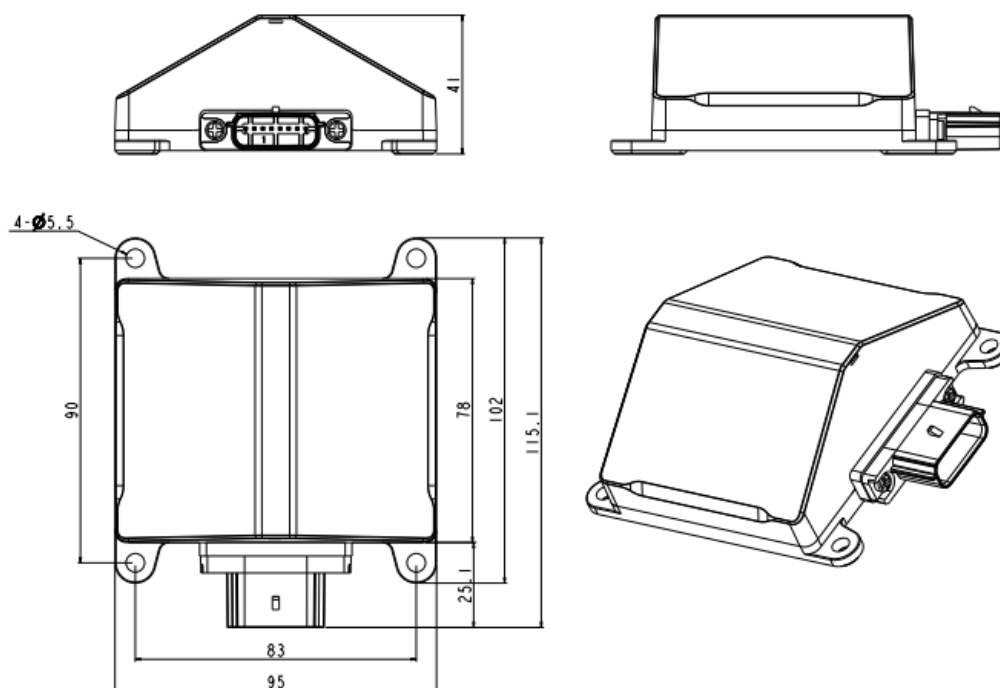

Figure 1-2 ASR100 dimensions

### Performance parameters:

working frequency	76-77GHz	
Maximum detection range	±80 m (vehicle) ±40 m (pedestrian/bicycle)	
working mode	slow speed	High speed
minimum detection range	0.25m	0.9m
distance resolution	0.31 m	0.96 m
distance accuracy	±0.16m	±0.5m
speed range	±60km/h	±150km/h
speed accuracy	±0.43km/h	
speed resolution	0.86km/h	

horizontal angle	180°
angular accuracy	±0.8°

### General parameters:

size	115mm x 95mm x 41mm
weight	2 30g
power consumption	6.5W
communication interface	CAN2.0
operating voltage _	8V - 32V; Passenger car 12V , Commercial vehicle 24V
operating temperature _	-40°C ~ 85°C
storage temperature	-40°C~105°C
installation angle redundancy	-2°~2°
protection rating _	IP69K
operating cycle	60ms

## 1.2 Warning display

The warning display is divided into 3 different segments, see picture below. The middle segment represents the front area (front zone) of the vehicle, 2.5meter (width) x 4.2 meter (length). The left and right segment represents the left and right corridor (left and right zone) next to the vehicle. It represents a rectangle area of 1 – 1.5meter(width) x 4.2 meter (length).

The brightness of the warning display adapts automatically to its ambient light environment.



**Figure 1-3 Warning Display**

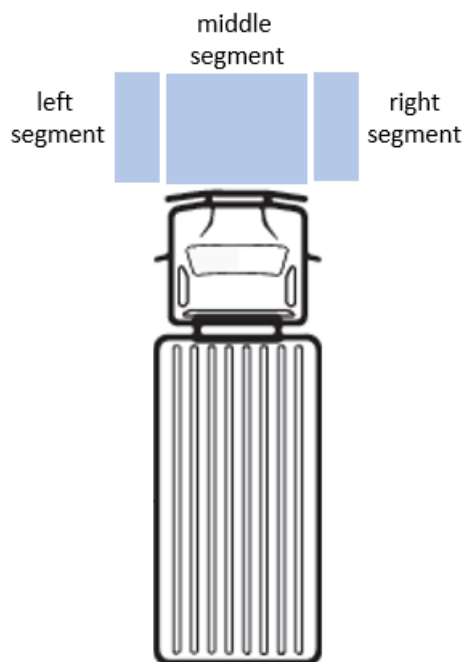

**Figure 1-4 Representation of the segments**

The warning function is divided into two levels as follows: (Note: Conditions for activating the warning function: The vehicle speed is less than or equal than 10km/h.)

- **Level 1 warning:** The vehicle is static. A red, yellow, or green light is shown if there is an object, for example a VRU (vulnerable road user) inside the left, middle or right zone. A light is shown if there is a static or moving object in middle zone. In the left and right zone, only moving object which is crossing the middle zone

will trigger a warning. A red light is shown if the object is less than 80cm away from the vehicle. A yellow light is shown if the object is between 80cm and 180cm from vehicle. A green light is shown if the object between 180cm and 420cm away from vehicle.

- **Level 2 Warning (collision warning):** The level two warning, or the collision warning once the vehicle is starting to move off and there is an there is an object which has the risk of an imminent collision with VRUs inside the left, right or middle zone. This results a blinking light and an acoustic sound.

*Please note that the audible collision warning when moving off is subject to the acceleration of the vehicle.*

The driver can get the approximate location of the object based on the segment of warning display.

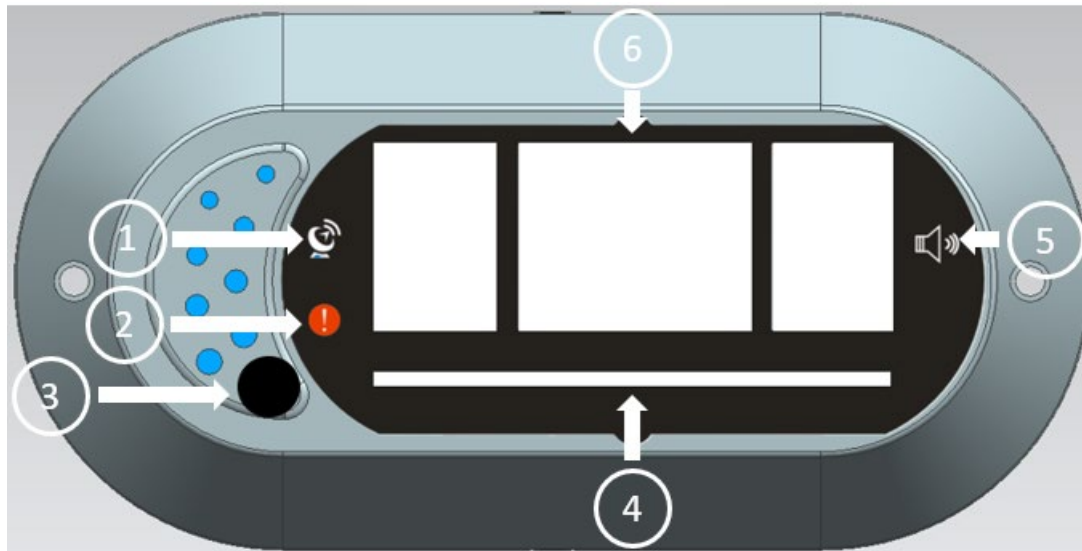

**Figure 1-5 Warning display description**

- ① GPS error indicator: lights up when the GPS sensor has no signal (temporarily), flashes when the GPS sensor has a permanent error signal.
- ② System error indicator: This indicator flashes when system has a malfunction. It lights up when the radar is blocked by ice, mud etc.
- ③ buzzer sound volume adjustment button
- ④ Power indicator: lights up when the display has power.

- ⑤ buzzer sound: lights up when the warning sound is turned on.
- ⑥ warning zone indicator: light up or flashes if there is an object inside the zone, according to level 1 and level 2 warning logic.

### 1.3 GPS&IMU module

This module integrates a high-precision gyroscope, an accelerometer and a GPS module. With this module, no input signal such as speed and acceleration from vehicle is needed.

### 1.4 System connections and the wiring harness

Connect each connector of the radar, display, GPS and IMU module harness as shown below.

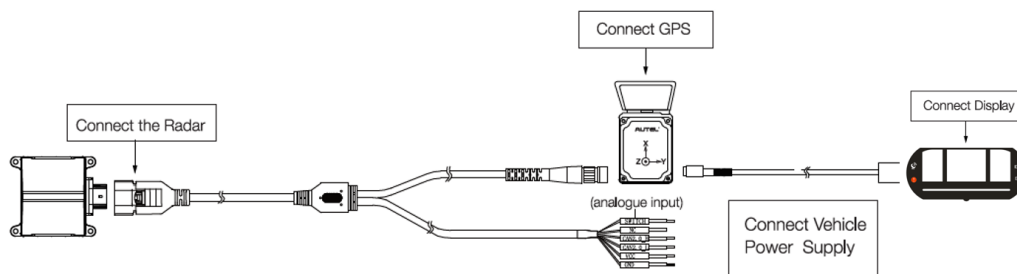

**Figure 1-6 System Connections Schematic**

## 2. Installation Guide

### 2.1 Radar installation

#### Notes on installation

- The radar should be mounted on a low-vibration component. Strong vibrations will affect the detection function.
- The radar should be installed on the most protruding level in the front of the truck to prevent it from being blocked by other parts and affecting its detection performance.
- The radar installation height should be between 60cm and 120cm.
- The radar should be installed in the center of the vehicle, see figure 2-1.

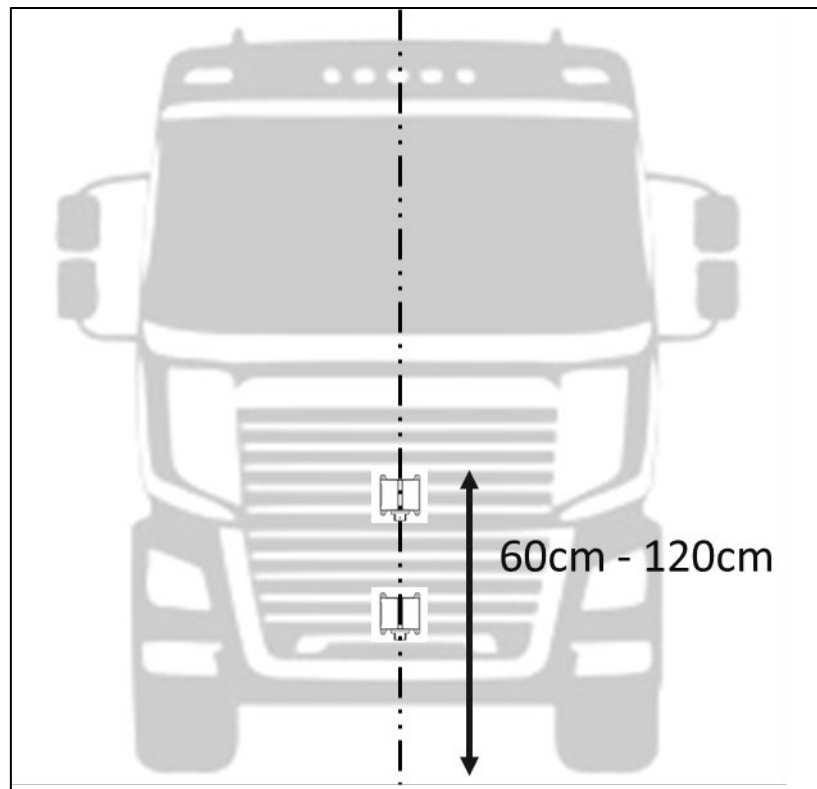

**Figure 2-1 Radar Center Installation**

**Installation Deviation:** To ensure detection accuracy, the horizontal angle error of the radar installation should be within  $\pm 1^\circ$  at best. The vertical angle error when installing is best within  $2^\circ$ .

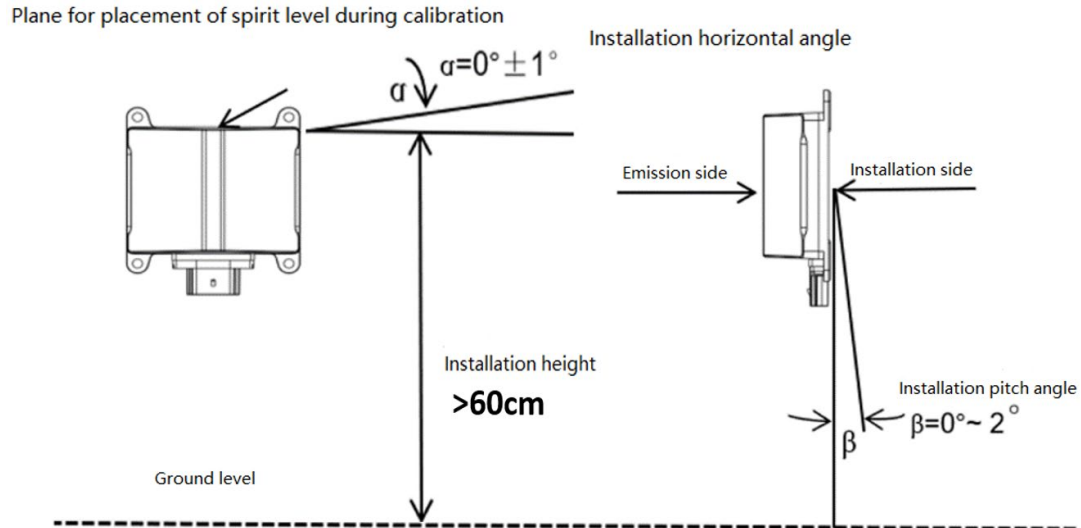

**Figure 2-3 Radar Installation Deviation Chart**

## 2.2 Power Access

The radar must be supplied via KL15 or terminal 15 (12V or 24V). We recommend you find KL15 on the main fuse board and connect the radar to it.

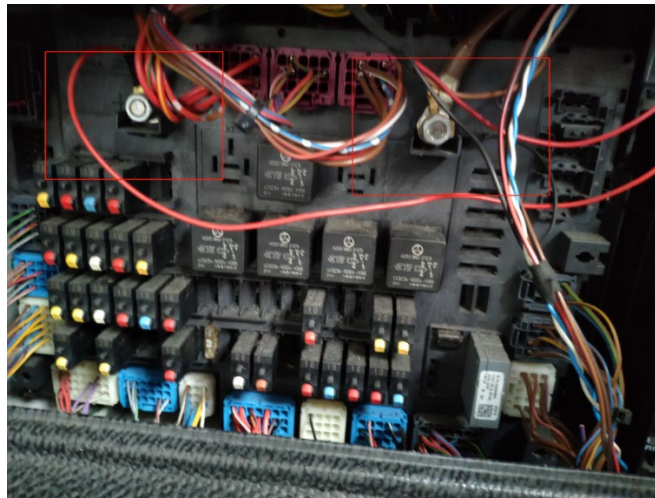

**Figure 2-3 Power Access**

## 2.3 Installation of GPS and IMU module

The GPS/IMU module can be placed anywhere in the driver's cabin, the preferred position is behind the windscreen and somewhere in the middle of the cab.

- Place the GPS&IMU module horizontally, noting that the X-axis direction is the same as the vehicle's forward direction.
- The module can be fixed with screws or double-sided tape.
- Connect the two harnesses at the end of the GPS&IMU module to the radar and the

display respectively.

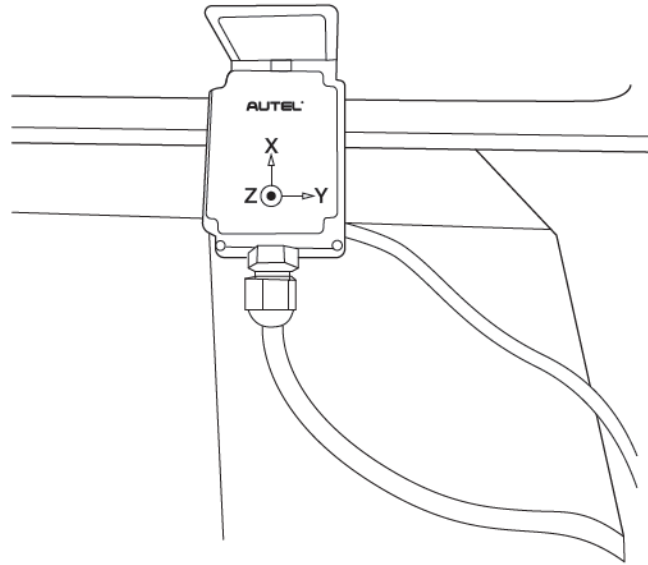

**Figure 2-4 GPS&IMU Module Installation**



**Référence:** E13\*10R06/01\*16316\*00

**Annexes:** - Rapport Technique  
- Fiche de Renseignements du constructeur

Bertrange, le 28 juin 2022

**Communication concernant:**<sup>(2)</sup>  
Communication concerning:

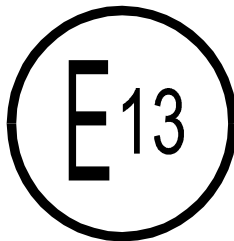

- **la délivrance d'une homologation**  
approval granted  
- ~~l'extension d'homologation~~  
~~approval extended~~  
- ~~le refus d'homologation~~  
approval refused  
- ~~le retrait d'homologation~~  
approval withdrawn  
- ~~l'arrêt définitif de la production~~  
production definitely discontinued

**d'un type de sous-ensemble électrique/électronique<sup>(2)</sup> en ce qui concerne le Règlement N° 10**  
of a type of electrical/electronic sub-assembly with regard to Regulation N° 10

**Numéro d'homologation par type:**  
Approval number:

E13\*10R06/01\*16316\*00

**Marque d'homologation:**  
Approval mark:

 10R - 06 16316

- Fabricant: (marque commerciale du constructeur):**  
Make (trade name of manufacturer): Autel
- Type:**  
Type: ASR100  
**Dénomination(s) commerciale(s) générale(s):**  
General commercial description(s): Side radar  
**Version(s):**  
Version(s):\_ ASR100

- 3. Moyens d'identification du type, s'ils sont marqués sur le véhicule / composant / entité technique<sup>(2)</sup>:**  
Means of identification of type, if marked on the vehicle / component / separate technical unit: ASR100
- 3.1. Emplacement de ce marquage:**  
Location of that marking: Engraved on the housing of the product
- 4. Catégorie du véhicule:**  
Category of vehicle: Not applicable
- 5. Nom et adresse du constructeur:**  
Name and address of manufacturer: Autel Intelligent Automobile Corp., Ltd.  
Floor 8, Floor 7 and Floor 4, Building B1,  
Zhiyuan, No. 1001 Xueyuan Avenue,  
Changyuan Community, Taoyuan Road,  
Nanshan District, Shenzhen City, Guangdong Province,  
P.R. China. Post Code: 518055
- 6. Dans le cas de composants ou d'entités techniques, emplacement et procédé de fixation de la marque de réception CEE:**  
In the case of components and separate technical units, location and method of affixing of the ECE approval mark: Engraved on the housing of the product
- 7. Adresse(s) de l' (des) usine(s) d'assemblage:**  
Address(es) of assembly plant(s): Autel Intelligent Automobile Corp., Ltd.  
Workroom 103, 104, 105, 106, 108, 1st Floor,  
Building A9, Tianliao Industrial Zone,  
Taoyuan Road, Nanshan District, Shenzhen City,  
Guangdong Province, P.R. China.  
Post Code: 518071
- 8. Informations supplémentaires (s'il y a lieu):**  
Additional informations (where applicable): See appendix below
- 9. Service technique responsable de l'exécution des essais:**  
Technical service responsible for carrying out the tests: TÜV Rheinland Luxemburg S.à r.l.  
2-4, rue Edmond Reuter  
L-5326 Contern
- 10. Date du rapport d'essai:**  
Date of test report: 16.02.2022
- 11. Numéro du rapport d'essai:**  
Number of test report: 85-R10-095/22-00
- 12. Remarques (s'il y a lieu):**  
Remarks (if any): See appendix below

13. **Lieu:** Bertrange  
Place:

14. **Date:** 28 juin 2022  
Date:

15. **Signature:**  
Signature:

**Pour le Ministre de la Mobilité  
et des Travaux publics**



**Alain DISFVISCOUR**  
Conseiller

**Pour la SNCH**

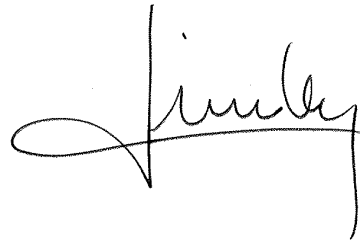

**Laurent LINDEN**  
Directeur opérationnel



16. **L'index de l'ensemble des renseignements déposé chez l'autorité de réception, qui peut être obtenu sur demande, est joint.**

The index to the information package lodged with the approval authority, which may be obtained on request, is attached.

See index to type-approval report

17. **Raison(s) de l'extension:** Not applicable  
Reason(s) for extension:

## Appendice

Appendix

### au certificat d'homologation par type N° E13\*10R06/01\*16316\*00

to type-approval certificate N° E13\*10R06/01\*16316\*00

### concernant l'homologation par type d'un sous ensemble électrique/électronique selon le Règlement N° 10.

concerning the type-approval of an electrical/electronic sub-assembly under Regulation N° 10.

- |   |  |   |                        |               |   |  |            |                 |   |  |
|---|--|---|------------------------|---------------|---|--|------------|-----------------|---|--|
| <b>1.</b>                                 | <b>Informations supplémentaires.</b><br>Additional information.  |   |                        |               |   |  |            |                 |   |  |
| <b>1.1.</b>                               | <b>Tension nominale du système électrique [V]:</b><br>Electrical system rated voltage [V]:   | DC 8 to 32 V  |                        |               |   |  |            |                 |   |  |
|   | <b>Masse:</b><br>Ground:   | <del>Positive</del> /negative <sup>(2)</sup>  |                        |               |   |  |            |                 |   |  |
| <b>1.2.</b>                               | <b>Ce SEEE peut être utilisé sur n'importe quel type de véhicule avec les restrictions suivantes:</b><br>This ESA can be used on any vehicle type with the following restrictions:   | No restrictions   |                        |               |   |  |            |                 |   |  |
| <b>1.2.1.</b>                             | <b>Conditions d'installation, s'il y a lieu:</b><br>Installation conditions, if any:   | Directly connected to car power and vertical installation   |                        |               |   |  |            |                 |   |  |
| <b>1.3.</b>                               | <b>CE SEEE peut seulement être utilisé sur les types de véhicules suivants:</b><br>This ESA can be used only on the following vehicle types:   | Not applicable  |                        |               |   |  |            |                 |   |  |
| <b>1.3.1.</b>                             | <b>Conditions d'installation, s'il y a lieu:</b><br>Installation conditions, if any:   | Not applicable  |                        |               |   |  |            |                 |   |  |
| <b>1.4.</b>                               | <b>La (les) méthode(s) spécifique(s) d'essais utilisée(s) et les bandes de fréquences couvertes pour déterminer l'immunité étai(ent): (indiquez s'il vous plaît à partir de l'annexe 9 la méthode précise utilisée).</b><br>The specific test method(s) used and the frequency ranges covered to determine immunity were: (Please specify precise method used from annex 9). | <table border="0"> <tr> <td>Bulk current injection</td> <td>20 to 400 MHz</td> </tr> <tr> <td>ISO 11452-4, 4<sup>th</sup> edition 2011</td> <td></td> </tr> <tr> <td>Free field</td> <td>400 to 2000 MHz</td> </tr> <tr> <td>ISO 11452-2, 2<sup>nd</sup> edition 2004</td> <td></td> </tr> </table> | Bulk current injection | 20 to 400 MHz | ISO 11452-4, 4 <sup>th</sup> edition 2011 |  | Free field | 400 to 2000 MHz | ISO 11452-2, 2 <sup>nd</sup> edition 2004 |  |
| Bulk current injection                    | 20 to 400 MHz  |   |                        |               |   |  |            |                 |   |  |
| ISO 11452-4, 4 <sup>th</sup> edition 2011 |  |   |                        |               |   |  |            |                 |   |  |
| Free field                                | 400 to 2000 MHz  |   |                        |               |   |  |            |                 |   |  |
| ISO 11452-2, 2 <sup>nd</sup> edition 2004 |  |   |                        |               |   |  |            |                 |   |  |
| <b>1.5.</b>                               | <b>Laboratoire accrédité au titre de la norme ISO 17025 et reconnu par l'autorité d'homologation chargé d'effectuer les essais:</b><br>Laboratory accredited to ISO 17025 and recognized by the Approval Authority responsible for carrying out the tests:   | Not applicable  |                        |               |   |  |            |                 |   |  |
| <b>2.</b>                                 | <b>Commentaires:</b><br>Remarks:   | None  |                        |               |   |  |            |                 |   |  |



**Référence:** E13\*10R06/01\*16316\*00

**Annexes:** - Rapport Technique  
- Fiche de Renseignements du constructeur

Bertrange, le 28 juin 2022

## Index du dossier d'homologation

Index to type-approval report

	<b>Numéro d'homologation:</b> Approval number:	E13*10R06/01*16316*00
	<b>Révision:</b> Revision:	00
	<b>Marque de fabrique ou de commerce:</b> Trade name or mark:	Autel
	<b>Type:</b> Type:	ASR100
1.	<b>Procès-verbal d'essai:</b> Test report:	N° 85-R10-095/22-00
	- Test report:	Page 1 to 4
	- Technical information:	Appendix L - Page 5 & 6
	- List of modifications:	Appendix 0 - Page 7
	- Test protocol:	Appendix 1 - Page 8 to 27
	- List of equipments:	Appendix 2 - Page 28
2.	<b>Dossier du constructeur:</b> Report of the manufacturer:	N° IF-Autel-ASR100-00
	- Manufacturer's information folder	Page 1 to 16
3.	<b>Autres documents annexés:</b> Other documents annexed:	Not applicable
4.	<b>Date de délivrance de l'homologation initiale:</b> Date of issue of initial type approval:	28.06.2022
5.	<b>Date de la dernière délivrance de pages révisées:</b> Date of last issue of revised pages:	Not applicable
6.	<b>Date de la dernière délivrance d'une homologation révisée:</b> Date of last extension:	Not applicable

Type : ASR100  
Manufacturer : Autel Intelligent Automobile Corp., Ltd.

---

## TEST REPORT

according to UN-Regulation

**Uniform provisions concerning the approval of vehicles  
with regard to electromagnetic compatibility**

**UN-Regulation No. 10**

including all amendments until

**Amendment 06, supplement 1**

---

Approval Status

EU/UN-Type approval : --

---

Structure of the Test Report

Item No.

- 0. General information
  - 1. Tested vehicle(s) / object(s)
  - 2. Test record
  - 3. Appendices
  - 4. Statement of conformity
- 

The Test Report shall be reproduced and published only in its entirety by the client. It may however be reproduced and published partially, but only with the written permission of the Technical Service.

Type : ASR100  
 Manufacturer : Autel Intelligent Automobile Corp., Ltd.

## 0. General information

- 0.1. Make (trade name of the manufacturer) : Autel
- 0.2. Type : ASR100  
 Version(s) : ASR100
- 0.3. Category of vehicle : Not applicable
- 0.4. Name and address of the manufacturer : Autel Intelligent Automobile Corp., Ltd.  
 Floor 8, Floor 7 and Floor 4, Building B1, Zhiyuan, No. 1001 Xueyuan Avenue, Changyuan Community, Taoyuan Road, Nanshan District, Shenzhen City, Guangdong Province, P.R. China. Post Code: 518055
- 0.5. No. of the Information folder : IF-Autel-ASR100-00  
 - Date of issue : January 14, 2022  
 - Date of last change : Not applicable

## 1. Tested vehicle(s) / object(s)

- 1.1. Description
- 1.1.1. ~~Vehicle~~ / object
- Trade name : Autel
- Type(s) / variant(s) / version(s) : ASR100 / --- / ASR100
- Identification number : Not applicable
- 1.1.2. Condition of ~~vehicle(s)~~ / Object(s) : New / ~~used~~ / ~~pre-tested~~
- 1.2. Worst case configuration : Only one variant/version, so no worst case assessment required.
- ~~There is no worst case selection applicable because all versions mentioned in the information folder are tested.~~
- ~~Based on the pre-test result / simulation analysis / WCC discussion record.~~
- ~~—Document no. and date:~~
- ~~Only one version is selected for test, because all versions use the same electronic components & layout & wires.~~
- 1.3. Remark : ---

Type : ASR100  
 Manufacturer : Autel Intelligent Automobile Corp., Ltd.

## 2. Test record

- 2.1. Equipment for measuring and testing : The test facilities / measurement equipment used were in compliance with the test requirements. Please see Appendix 2.
- 2.1.1. Specifications for the test site : Not applicable
- 2.1.2. Subcontracting : Not applicable
- 2.2. Test results
- Remark concerning extension : ~~The component type has been tested according to the modification(s) mentioned in appendix 0.~~  
 The new parts meet the requirements of the regulation.  
 An actual practical test of the object was not necessary. The results of the previous test(s) are still valid.
- 2.2.1. Test results referring to measurement
- 2.2.1.1. General requirements : All general requirements are met.  
 (Test data see Appendix 1)
- 2.2.1.2. Test results – radiated narrowband electromagnetic emissions : The requirements of the standards are met.  
 (Test data see Appendix 1)
- 2.2.1.3. Test results – radiated broadband electromagnetic emissions : The requirements of the standards are met.  
 (Test data see Appendix 1)
- 2.2.1.4. Test results – Immunity to electromagnetic radiation : The requirements of the standards are met.  
 (Test data see Appendix 1)
- 2.2.1.5. Test results – conducted Emission : The requirements of the standards are met.  
 (Test data see Appendix 1)
- 2.2.1.6. Test results – immunity to conducted Transients : The requirements of the standards are met.  
 (Test data see Appendix 1)
- 2.2.2. Test results of not measurable attributes : Not applicable
- 2.2.3. Alternative test methods : Not applicable

Type : ASR100  
Manufacturer : Autel Intelligent Automobile Corp., Ltd.

---

- 2.3. Additional information : The results of the test refer exclusively to the object(s) mentioned under point 1. of this report.
- Test site : TÜV Rheinland (Guangdong) Co., Ltd. EMC Laboratory  
No.102, 1F of Southwest Warehouse Building, No.767 TianYuan Road, Tianhe District, Guangzhou, P.R.China,
- Test date : January 17-22, 2022
- 2.4. Remarks : Not applicable

### 3. Appendices

- Appendix L : Technical information about the electrical/electronic sub-assembly (ESA) according to Annex 3B for the communication concerning the UN-type approval
- Appendix 0 : List of modifications
- Appendix 1 : Test protocol
- Appendix 2 : List of equipments
- Information folder No. : IF-Autel-ASR100-00

### 4. Statement of conformity

The Information Document listed in section 0.5., and the type described therein, comply with the requirements stated on page 1.

The test results in this report refer to the ~~vehicle(s)~~ object(s) described under section 1.1.

With regards to the required level of performance to be achieved, the tested samples were representative for the type to be approved (see section 1.2).

Engineering Centre Shanghai, February 16, 2022  
JZ



Jennifer Zhang  
Technical Expert Technical Service

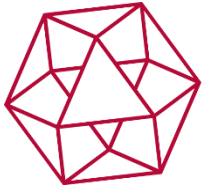

# NSAI

## ECE TYPE-APPROVAL CERTIFICATE



Communication Concerning:<sup>2</sup> Approval granted  
~~Approval extended~~  
~~Approval refused~~  
~~Approval withdrawn~~  
~~Production definitively discontinued~~

Of a type of ~~vehicle~~/component/~~separate technical unit~~<sup>2</sup> with regard to Regulation No. 10.  
Of a type of electrical/electronic sub-assembly<sup>2</sup> with regard to Regulation No.10.

Approval No: **E24\*10R06/01\*4187\*00**

Reason for extension: -N/A

1. Make (trade name of manufacturer): ***Autel***

2. Type and general commercial description: ***ASI-100***

Variant(s): ***N/A***

3. Means of identification of type, if marked on the ~~vehicle~~/  
component/separate technical unit<sup>2</sup>: ***Type Designation***

3.1 Location of that marking: ***On the bottom of the product***

4. Category of vehicle: ***N/A***

5. Name and address of manufacturer: ***Autel Intelligent Automobile Corp.,  
Ltd. Floor 8, Floor 7 and Floor 4,  
Building B1, Zhiyuan, No.1001 Xueyuan  
Avenue, Changyuan Community,  
Taoyuan Road, Nanshan District  
Shenzhen City, Guangdong  
Province, P.R. China Post Code:  
518055***

6. In the case of components and separate technical units,  
location and method of affixing of the approval mark: ***adhesive label on the bottom of the  
product***

7. Address(es) of assembly plant(s): ***Autel Intelligent Automobile Corp.,  
Ltd. Workroom 103 104. 105. 106. 108.  
1st Floor, Building A9, Tianliao  
Industrial Zone, Taoyuan Road,  
Nanshan District, Shenzhen City,  
Guangdong Province, P.R. China***



# NSAI

Approval No: E24\*10R06/01\*4187\*00

- |  |  |
|--|--|
| 8. Additional information (where applicable):  | <i>See appendix below</i>                              |
| 9. Technical service responsible for carrying out the tests:                                     | <i>SGS-TUV Saar GmbH<br/>Am TUV 1 D-66280 Sulzbach</i> |
| 10. Date of test report:   | <i>02.09.2022</i>                                      |
| 11. Number of test report:   | <i>HOM ECN T22/070-00</i>                              |
| 12. Remarks (if any):  | <i>See Appendix below</i>                              |
| 13. Place:   | <i>Dublin</i>  |
| 14. Date:  | <i>21<sup>st</sup> October, 2022</i>                   |
| 15. Signature:  |  |



16. The index to the information package lodged with the approval authority, which may be obtained on Request, is attached.

- 
1. Distinguishing number of the country which issued/extended/refused or withdrawn approval. (see Regulation, provisions on approval).
  2. Strike out what does not apply.



# NSAI

Approval No: E24\*10R06/01\*4187\*00

## Appendix

To type-approval communication concerning the type approval of an electrical/electronic sub-assembly under Regulation No.10.

1. Additional information
  - 1.1. Electrical system rated voltage: *DC 12V~24V, negative ground*
  - 1.2. This ESA can be used on any vehicle type with the following restrictions: *See manufacturer's specifications.*
    - 1.2.1 Installation conditions, if any: *See manufacturer's specifications.*
  - 1.3. This ESA can only be used on the following vehicle types: *N/A*
    - 1.3.1 Installation conditions, if any: *N/A*
  - 1.4. The specific test method(s) used and the frequency ranges covered to determine immunity were: *Bulk Current Injection Method:  
Frequency: (20 – 400 MHz)  
Absorber Chamber Test:  
Frequency: (400 – 2000 MHz)*
  - 1.5. Laboratory accredited to ISO 17025 and recognized by the Approval Authority responsible for carrying out the tests: *SGS-TUV Saar GmbH*
2. Remarks: *N/A*

Appendix to type-approval communication concerning the type approval of a vehicle under Regulation No.10.

1. Additional information
2. Electrical system rated voltage: *N/A*
3. Type of bodywork: *N/A*
4. List of electronic systems installed in the tested vehicle(s) not limited to the items in the information document: *N/A*
  - 4.1. Vehicle equipped with 24 GHz short-range radar equipment (yes/no/optional)<sup>2</sup>: *N/A*
5. Laboratory accredited to ISO 17025 and recognized by the Approval Authority responsible for carrying out the tests: *N/A*
6. Remarks: *N/A*



# NSAI

Approval No: E24\*10R06/01\*4187\*00

## Index to the Information Package

Date of issue:	<i>21<sup>st</sup> October, 2022</i>
Date of latest amendment:	<i>N/A</i>
Reason for extension/revision:	<i>N/A</i>
1. Additional conditions, and advisory notes on legal alternatives.	
2. Test report(s)	
- numbers(s):	<i>HOM ECN T22/070-00</i>
- date of issue:	<i>02.09.2022</i>
- date of latest amendment:	<i>N/A</i>
3. Information document	
- number(s):	<i>IF_ASI-100_R10.06_00</i>
- date of issue:	<i>25.08.2022</i>
- date of latest amendment:	<i>N/A</i>
Documentation:	<i>75 pages</i>



# NSAI

Approval No: E24\*10R06/01\*4187\*00

## Appendix: **Additional conditions, and advisory notes on legal alternatives**

### A: Additional conditions:

1. The attached technical report, with any of its attachments, forms part of this Type Approval certificate.
2. Each device from series production shall be to the measurements specified in the attached drawings, and shall be manufactured only from the materials specified in the Approval documents.
3. Changes in the type are permitted only with the explicit permission of NSAI. Breaches of this requirement will lead to a withdrawal of the Type Approval, and in addition may be subject to criminal prosecution.
4. At regular intervals, any tests or associated checks prescribed by the applicable legislation to verify continued conformity with the approved type shall be carried out. The manufacturer shall demonstrate compliance with this by submitting to NSAI evidence of adequate arrangements and documented control plans for each type approved.
5. Any set of samples or test pieces showing evidence of non-conformity shall give rise to further sampling and testing and all steps shall be taken to restore conformity of production.
6. This Type Approval will expire when it is surrendered by the holder, or withdrawn by NSAI, or when the approved type no longer conforms to legal requirements. The recall of the Type Approval can be issued by NSAI when the conditions required for the issuing or continuation of the Type Approval are no longer current, or when the Approval holder is in breach of the duties attached to the Type Approval, or when it is established that the approved type no longer meets the requirements of traffic safety.
7. Changes in the company name, address or manufacturing site, as well as in any of the sales or other agents specified in the issuing of the approval must immediately be notified to NSAI.
8. The duties imposed by the issuing of this certificate are not transferable. The legal protection of third parties is not affected by this certificate.
9. When the manufacture or sale of the system, component or separate technical unit has not been started within one year of the date of issue of this certificate, then NSAI is to be informed. This requirement also applies when the manufacture or sale has been halted for more than one year, or when it ought to have been halted for more than one year. The initial commencement of manufacture or sale, or the resumption of manufacture or sale, shall then be notified to NSAI within one month of commencement or resumption.

### B: Legal Options:

Any objection to the requirements set out in this certificate shall be made within one month of the date of issue. The objection shall be made, in writing, to NSAI in Dublin.

---

# Technical Report

V00

Test standard:  
**ECE R10**

Level of amendment:  
**06 Series of amendments, 01 supplement**

Title:  
**Electromagnetic compatibility**

---

Manufacturer:  
**Autel Intelligent Automobile Corp., Ltd.**

Type:  
**ASI-100**

---

Subject of testing:  
**Component**

**0      General:**

0.1	Make (trade name of manufacturer):	Autel
0.2	Type:	ASI-100
0.2.1	Variant:	n.a.
0.2.2	Commercial description(s):	n.a.
0.3	Means of identification of type, if marked on the vehicle / component / technical unit:	Type designation
0.3.1	Location of that markings:	refer to information document
0.4	Category of vehicle:	n.a.
0.5	Manufacturer's name and address:	Autel Intelligent Automobile Corp., Ltd.  Floor 8, Floor 7 and Floor 4, Building B1, Zhiyuan, No.1001 Xueyuan Avenue, Changyuan Community, Taoyuan Road, Nanshan District Shenzhen City, Guangdong Province, P.R. China Post Code: 518055
0.8	Name(s) and address(es) of assembly plant(s):	Autel Intelligent Automobile Corp., Ltd.  Workroom 103 104. 105. 106. 108. 1st Floor, Building A9, Tianliao Industrial Zone, Taoyuan Road, Nanshan District, Shenzhen City, Guangdong Province, P.R. China
0.9	Name and address of representative:	n.a.
	Location of the approval mark:	refer to information document

---

1 **Test record:**

See appendix

2 **Attachments:**

- |     |                        |  |
|-----|------------------------|--|
| 2.1 | List of modifications: | Refer to attachment 2.1                                |
| 2.2 | Information folder:    | No.: IF_ ASI-100_R10.06_00<br>Date of issue: 25.08.202 |
| 2.3 | Test Report:           | No.: SZEM220800563801<br>Date of issue: 11.08.2022     |

**3 Statement of conformity:**

The information folder as mentioned under no. 2.2 and the type described therein are in compliance with the test standard mentioned above. With regard to the required level of performance to be achieved, the test specimen were representative for the type to be approved.

The tests were carried out in accordance to the relevant requirements of the

EN ISO/IEC 17025                       EN ISO/IEC 17020

**Test Laboratory**  
**SGS-TÜV Saar GmbH**

notified by

Kraftfahrt-Bundesamt (KBA),  
Federal Republic of Germany

National Standards  
Authority of Ireland (NSAI)

Rijksdienst voor het  
Wegverkeer (RDW),  
The Netherlands

**No. KBA - P 00084 – 10**

**No. 101**

**No. 99050064 00**

Responsible expert

Conformity check by



Gangling Zhang

Natalia Zhang

Shanghai, 02.09.2022

This Technical Report shall be reproduced and published in full only and by the client only. It shall be reproduced partially with the written permission of the Test Laboratory only.

This document is issued by the Company subject to its General Conditions of Service ([www.sgsgroup.de/agb](http://www.sgsgroup.de/agb)). Attention is drawn to the limitations of liability, indemnification and jurisdictional issues established therein. This document is an original. If the document is submitted digitally, it is to be treated as an original within the meaning of UCP 600. Any holder of this document is advised that information contained hereon reflects the Company's findings at the time of its intervention only and within the limits of client's instructions, if any. The Company's sole responsibility is to its Client and this document does not exonerate parties to a transaction from exercising all their rights and obligations under the transaction documents. Any unauthorized alteration, forgery or falsification of the content or appearance of this document is unlawful and offenders may be prosecuted to the fullest extent of the law.

To assess the conformity, the laboratory refers to the "scope classification" of the Kraftfahrt-Bundesamt (KBA) – Federal Motor Transport Authority (in its valid version at the time of testing) and the specified consideration of the measurement uncertainty for the related test procedure.

In case the measurement uncertainty does not need to be considered according to the scope classification, the laboratory considers the result conform if its measured value is within the specification.

In case the measurement uncertainty does need to be considered according to the scope classification, the laboratory considers the result conform if its value incl. its measurement uncertainty is within the specification.

**Test record**

**1 Test conditions**

- 1.1 Test component
- 1.1.1 Function description IMU module
- 1.1.2 Type ASI-100
- 1.1.3 Variant n.a
- 1.1.4 Tested operating mode(s) See test report of the enclosure.
- 1.1.5 Tested rated voltage(s)  12V  24V  12V/24V
- 1.1.6 The approval object is ...
- an ESA that is not related to a connection system for charging a REESS  yes  
 no
- a complete connection system for charging a REESS  yes  
 no
- a component of a connection system for charging a REESS  yes  
 no
- Have the HV voltages and HV currents been taken into account in the tests and measurements?  yes  
 no  
 n.a.
- a light source or a part of a light source acc. to item 3.2.10 of the Regulation?  yes  
 no  
 n.a.
- 1.1.7 Approval number or number of test report  n.a.
- Do the devices of the type have immunity related functions?  yes  
 no
- Reason if necessary: IMU module related to safety functions and within ECE R10.06, 2.12
- 1.1.8 Do the devices of the type have to be in operation during the engine start phase?  yes  
 no
- 1.1.9 Photo documentation of the examinee including existing labels See test report of the enclosure.
- 1.1.10 Remarks:  n.a.
- 1.2 Test equipment



**Technical Report**  
**No.: HOM ECN T22/070-00**  
**Type: ASI-100**  
**Appendix**

---

Parameter of the test area:

The equipment, on which the tests were carried out, fulfilled the requirements of the Regulation.

**2      Test Results**

2.1	Test results in configurations <u>other</u> than „REESS charging mode coupled of the power grid	<input checked="" type="checkbox"/> fulfilled <input type="checkbox"/> not fulfilled <input type="checkbox"/> n.a.
	Remarks:	<input checked="" type="checkbox"/> n.a.
2.1.1	Measurement of <u>radiated broadband</u> electromagnetic emissions from electrical/ electronic subassemblies according to item 6.5 of the Regulation:	<input checked="" type="checkbox"/> fulfilled <input type="checkbox"/> not fulfilled <input type="checkbox"/> n.a.
2.1.1.1	Measurement procedure:	Quasi-peak-detector
2.1.1.2	Measurement setup:	Anechoic chamber
2.1.1.3	Measurement results:	The measured values, expressed in dB $\mu$ V/m, are below the reference limits. See test report of the enclosure
2.1.1.4	Photo documentation of the measurement setup (if applicable):	See test report of the enclosure.
2.1.1.5	Remarks:	<input checked="" type="checkbox"/> n.a.
2.1.2	Measurement of <u>radiated narrowband</u> electromagnetic emissions from electrical/ electronic subassemblies according to item 6.6 of the Regulation:	<input checked="" type="checkbox"/> fulfilled <input type="checkbox"/> not fulfilled <input type="checkbox"/> n.a.
2.1.2.1	Measurement procedure:	Average-detector
2.1.2.2	Measurement setup:	Anechoic chamber
2.1.2.3	Measurement results:	The measured values, expressed in dB $\mu$ V/m, are below the reference limits. See test report of the enclosure.
2.1.2.4	Photo documentation of the measurement setup (if applicable):	See test report of the enclosure.
2.1.2.5	Remarks:	<input checked="" type="checkbox"/> n.a.

2.1.3 Testing for emission of transient conducted disturbances of electrical/electronic subassemblies on 12/24/48 V supply lines according to item 6.7 of the Regulation:  fulfilled  
 not fulfilled  
 n.a.

2.1.3.1 Test results: The limits are kept. See test report of the enclosure.

2.1.3.2 Photo documentation of the measurement setup (if applicable): See test report of the enclosure.

2.1.3.3 Remarks:  n.a.  
 See below table.

For 12V system (Test Voltage: 13.5V)

Limit	Measured Value [V]			
	Slow pulse OFF→ON	Slow pulse ON→OFF	Fast pulse OFF→ON	Fast pulse ON→OFF
+75V	+0.9V	+0.5V	+0.9V	+0.5V
-100V	-13.9V	-14.3V	-13.9V	-14.3V

For 24V system

Limit	Measured Value [V]			
	Slow pulse OFF→ON	Slow pulse ON→OFF	Fast pulse OFF→ON	Fast pulse ON→OFF
+150V	+8.2V	+1.4V	+8.6V	+1V
-450V	-28.2V	-28.6V	-28.2V	-28.6V

2.1.4 Testing for radiated immunity of electrical/electronic subassemblies to electromagnetic radiation according to item 6.8 of the Regulation:  fulfilled  
 not fulfilled  
 n.a.

2.1.4.1 Test procedure: Bulk current injection (BCI) (20-400 MHz) and Absorber chamber (400-2000 MHz)

2.1.4.2 Test setup: See test report of the enclosure.

2.1.4.3 Test results: During the test was no degradation of performance of „functions related to immunity“ (acc. to 2.12).

2.1.4.4 Photo documentation of the measurement setup (if applicable): See test report of the enclosure.

- |         |   |  |
|---------|---|--|
| 2.1.4.5 | Remarks:  | <input type="checkbox"/> n.a.<br>ESA safety-related according to item 2.12 of the Regulation.                            |
| 2.1.5   | Testing for <u>immunity to transient disturbances</u> conducted along on 12/24 V supply lines of electrical/electronic subassemblies according to item 6.9 of the Regulation: | <input checked="" type="checkbox"/> fulfilled<br><input type="checkbox"/> not fulfilled<br><input type="checkbox"/> n.a. |
| 2.1.5.1 | Test results:   | During the test was no unacceptable degradation. See test report of the enclosure.                                       |
| 2.1.5.2 | Photo documentation of the measurement setup (if applicable):   | See test report of the enclosure.  |
| 2.1.5.3 | Remarks:  | <input checked="" type="checkbox"/> n.a.   |
| 2.2     | Test results in configurations „REESS charging mode coupled of the power grid:  | <input type="checkbox"/> fulfilled<br><input type="checkbox"/> not fulfilled<br><input checked="" type="checkbox"/> n.a. |
|         | Remarks:  | <input checked="" type="checkbox"/> n.a.<br><br>Test component not related to REESS                                      |



Technical Report  
No.: HOM ECN T22/070-00  
Type: ASI-100  
Appendix

---

3 **Other Information**

3.1 Date of test: 2022-08-01 to 2022-08-04

3.2 Place of test: SGS-CSTC Standards Technical Services Co., Ltd. Shenzhen Branch Room 105, Building A, Xinlong Technology Industrial Park, No. 50 Fengtang Road, Xintian Community, Fuyong Street, Bao'an District, Shenzhen, China

4 **Remarks:**  n.a.



---

**List of modifications:**

- |   |                  |      |
|---|------------------|------|
| 1 | Correction of:   | n.a. |
| 2 | Modification of: | n.a. |
| 3 | Addition of:     | n.a. |
| 4 | Deletion of:     | n.a. |

# TEST REPORT

**Application No.:** SZEM2208005638AU  
**Applicant:** Autel Intelligent Automobile Corp., Ltd.  
**Address of Applicant:** Floor 8, Floor 7 and Floor 4, Building B1, Zhiyuan, No.1001 Xueyuan Avenue, Changyuan Community, Taoyuan Road, Nanshan District Shenzhen City, Guangdong Province, P.R. China Post Code: 518055  
**Manufacturer:** Autel Intelligent Automobile Corp., Ltd.  
**Address of Manufacturer:** Floor 8, Floor 7 and Floor 4, Building B1, Zhiyuan, No.1001 Xueyuan Avenue, Changyuan Community, Taoyuan Road, Nanshan District Shenzhen City, Guangdong Province, P.R. China Post Code: 518055  
**Factory:** Autel Intelligent Automobile Corp., Ltd  
**Address of Factory:** Workroom 103 104. 105. 106. 108. 1st Floor, Building A9, Tianliao Industrial Zone, Taoyuan Road, Nanshan District, Shenzhen City, Guangdong Province, P.R. China

### Equipment Under Test (EUT):

**EUT Name:** IMU module  
**Model No.:** ASI-100  
**Trade Mark:** Autel  
**Standard(s) :** ECE R10.06  
**Date of Receipt:** 2022-08-01  
**Date of Test:** 2022-08-01 to 2022-08-04  
**Date of Issue:** 2022-08-11

<b>Test Result:</b>	<b>Pass*</b>
---------------------	--------------

\* In the configuration tested, the EUT complied with the standards specified above.

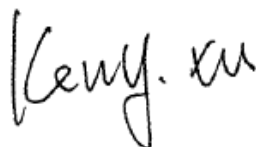

Keny Xu  
EMC Laboratory Manager



Unless otherwise agreed in writing, this document is issued by the Company subject to its General Conditions of Service printed overleaf, available on request or accessible at <http://www.sgs.com/en/Terms-and-Conditions.aspx> and, for electronic format documents, subject to Terms and Conditions for Electronic Documents at <http://www.sgs.com/en/Terms-and-Conditions/Terms-e-Documents.aspx>. Attention is drawn to the limitation of liability, indemnification and jurisdiction issues defined therein. Any holder of this document is advised that information contained hereon reflects the Company's findings at the time of its intervention only and within the limits of Client's instructions, if any. The Company's sole responsibility is to its Client and this document does not exonerate parties to a transaction from exercising all their rights and obligations under the transaction documents. This document cannot be reproduced except in full, without prior written approval of the Company. Any unauthorized alteration, forgery or falsification of the content or appearance of this document is unlawful and offenders may be prosecuted to the fullest extent of the law. Unless otherwise stated the results shown in this test report refer only to the sample(s) tested and such sample(s) are retained for 30 days only.  
**Attention: To check the authenticity of testing /inspection report & certificate, please contact us at telephone: (86-755) 8307 1443, or email: CN.Doccheck@sgs.com**

Room 105, Building A, Xixiang Technology Industrial Park, No. 50 Fenggang Road, Xixiang Community, Fuyong Street, Bao'an District, Shenzhen, China 518103 t (86-755) 26012053 f (86-755) 26710594 www.sgs.com.cn  
中国·深圳·宝安区福永街道新田社区凤岗大道50号鑫龙科技园A栋105室 邮编: 518103 t (86-755) 26012053 f (86-755) 26710594 sgs.china@sgs.com

## SGS-CSTC Standards Technical Services Co., Ltd. Shenzhen Branch

SZEMC-TRF-01 Rev. A/0 Aug01,2022

Report No.: SZEM220800563801

Page: 2 of 54

Revision Record				
Version	Chapter	Date	Modifier	Remark
01		2022-08-11		Original

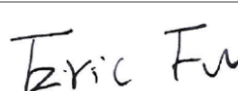
Authorized for issue by:				
				
		_____		
		<b>Powell Bao/Project Engineer</b>		
				
		_____		
		<b>Eric Fu/Reviewer</b>		



SGS-CSTC Standards Technical Services Co., Ltd.  
Shenzhen Branch Testing & Calibration Laboratory

Unless otherwise agreed in writing, this document is issued by the Company subject to its General Conditions of Service printed overleaf, available on request or accessible at <http://www.sgs.com/en/Terms-and-Conditions.aspx> and, for electronic format documents, subject to Terms and Conditions for Electronic Documents at <http://www.sgs.com/en/Terms-and-Conditions/Terms-e-Documents.aspx>. Attention is drawn to the limitation of liability, indemnification and jurisdiction issues defined therein. Any holder of this document is advised that information contained hereon reflects the Company's findings at the time of its intervention only and within the limits of Client's instructions, if any. The Company's sole responsibility is to its Client and this document does not exonerate parties to a transaction from exercising all their rights and obligations under the transaction documents. This document cannot be reproduced except in full, without prior written approval of the Company. Any unauthorized alteration, forgery or falsification of the content or appearance of this document is unlawful and offenders may be prosecuted to the fullest extent of the law. Unless otherwise stated the results shown in this test report refer only to the sample(s) tested and such sample(s) are retained for 30 days only.  
**Attention: To check the authenticity of testing /inspection report & certificate, please contact us at telephone: (86-755) 8307 1443, or email: CN.Doccheck@sgs.com**

Room 105, Building A, Xixiang Technology Industrial Park, No. 50 Fengtang Road, Xixiang Community, Fuyong Street, Bao'an District, Shenzhen, China 518103 t (86-755) 26012053 f (86-755) 26710594 www.sgs.com.cn  
中国·深圳·宝安区福永街道新田社区凤塘大道50号鑫龙科技工业园A栋105室 邮编: 518103 t (86-755) 26012053 f (86-755) 26710594 sgs.china@sgs.com

## 2 Test Summary

Emission Part				
Item	Standard	Method	Requirement	Result
Radiated Emission (30MHz-1GHz)	ECE R10.06	CISPR 25:2002	Clause 6.5 & 6.6 of R10-06	Pass
Conducted transient disturbances		ISO 7637-2:2004	Clause 6.7 of R10-06	Pass

Immunity Part				
Item	Standard	Method	Requirement	Result
Conducted transient immunity	ECE R10.06	ISO 7637-2:2004	Clause 6.9 of R10-06	Pass
Bulk Current Injection (20MHz-400MHz)		ISO 11452-4:2011	Clause 6.8 of R10-06:60mA, 80%, 1kHz. AM(Amplitude Modulation)	Pass
Radiation immunity-ALSE (400MHz-2GHz)		ISO 11452-2:2004	Clause 6.8 of R10-06:400MHz to 800MHz: 30V/m,80%, 1kHz. AM (Amplitude Modulation); 800MHz to 2GHz: 30V/m, Ton=577 μs, period=4600 μs, PM (Pulse Modulation)	Pass



Unless otherwise agreed in writing, this document is issued by the Company subject to its General Conditions of Service printed overleaf, available on request or accessible at <http://www.sgs.com/en/Terms-and-Conditions.aspx> and, for electronic format documents, subject to Terms and Conditions for Electronic Documents at <http://www.sgs.com/en/Terms-and-Conditions/Terms-e-Documents.aspx>. Attention is drawn to the limitation of liability, indemnification and jurisdiction issues defined therein. Any holder of this document is advised that information contained hereon reflects the Company's findings at the time of its intervention only and within the limits of Client's instructions, if any. The Company's sole responsibility is to its Client and this document does not exonerate parties to a transaction from exercising all their rights and obligations under the transaction documents. This document cannot be reproduced except in full, without prior written approval of the Company. Any unauthorized alteration, forgery or falsification of the content or appearance of this document is unlawful and offenders may be prosecuted to the fullest extent of the law. Unless otherwise stated the results shown in this test report refer only to the sample(s) tested and such sample(s) are retained for 30 days only.

**Attention: To check the authenticity of testing /inspection report & certificate, please contact us at telephone: (86-755) 8307 1443, or email: CN.Doccheck@sgs.com**

SGS-CSTC Standards Technical Services Co., Ltd.  
Shenzhen Branch Testing & Calibration Laboratory

Room 105, Building A, Xinlong Technology Industrial Park, No. 30 Fengqiang Road, Xintian Community, Fuyong Street, Bao'an District, Shenzhen, China 518103 t (86-755) 26012053 f (86-755) 26710594 www.sgs.com.cn  
中国·深圳·宝安区福永街道新田社区凤塘大道50号鑫龙科技园A栋105室 邮编: 518103 t (86-755) 26012053 f (86-755) 26710594 sgs.china@sgs.com

### 3 Contents

	Page
1 COVER PAGE .....	1
2 TEST SUMMARY .....	3
3 CONTENTS .....	4
4 GENERAL INFORMATION .....	6
4.1 DETAILS OF E.U.T. ....	6
4.2 DESCRIPTION OF SUPPORT UNITS .....	6
4.3 MEASUREMENT UNCERTAINTY .....	6
4.4 TEST LOCATION.....	7
4.5 TEST FACILITY.....	7
4.6 DEVIATION FROM STANDARDS.....	7
4.7 ABNORMALITIES FROM STANDARD CONDITIONS .....	7
4.8 EMS MONITOR.....	7
5 EQUIPMENT LIST.....	8
6 EMISSION TEST RESULTS .....	11
6.1 RADIATED EMISSION(30MHZ-1GHZ).....	11
6.1.1 E.U.T. Operation .....	12
6.1.2 Test Mode Description .....	12
6.1.3 Test Setup Diagram.....	13
6.1.4 Measurement Procedure and Data.....	14
6.2 CONDUCTED TRANSIENT DISTURBANCES.....	23
6.2.1 E.U.T. Operation .....	23
6.2.2 Test Mode Description .....	23
6.2.3 Test Setup Diagram.....	24
6.2.4 Measurement Procedure and Data.....	24
7 IMMUNITY TEST RESULTS .....	33
7.1 CONDUCTED TRANSIENT IMMUNITY .....	34
7.1.1 Test Setup Diagram.....	34
7.1.2 E.U.T. Operation .....	34
7.1.3 Test Mode Description .....	35
7.1.4 Test Condition and Results:.....	35
7.2 BULK CURRENT INJECTION(20MHZ-400MHZ) .....	36
7.2.1 Test Setup Diagram.....	36
7.2.2 E.U.T. Operation .....	36
7.2.3 Test Mode Description .....	36
7.2.4 Test Condition and Results:.....	37
7.3 RADIATION IMMUNITY-ALSE(400MHZ-2GHZ) .....	38
7.3.1 Test Setup Diagram.....	38
7.3.2 E.U.T. Operation .....	39



Unless otherwise agreed in writing, this document is issued by the Company subject to its General Conditions of Service printed overleaf, available on request or accessible at <http://www.sgs.com/en/Terms-and-Conditions.aspx> and, for electronic format documents, subject to Terms and Conditions for Electronic Documents at <http://www.sgs.com/en/Terms-and-Conditions/Terms-e-Documents.aspx>. Attention is drawn to the limitation of liability, indemnification and jurisdiction issues defined therein. Any holder of this document is advised that information contained hereon reflects the Company's findings at the time of its intervention only and within the limits of Client's instructions, if any. The Company's sole responsibility is to its Client and this document does not exonerate parties to a transaction from exercising all their rights and obligations under the transaction documents. This document cannot be reproduced except in full, without prior written approval of the Company. Any unauthorized alteration, forgery or falsification of the content or appearance of this document is unlawful and offenders may be prosecuted to the fullest extent of the law. Unless otherwise stated the results shown in this test report refer only to the sample(s) tested and such sample(s) are retained for 30 days only.

Attention: To check the authenticity of testing / inspection report & certificate, please contact us at telephone: (86-755) 8307 1443, or email: [CN.Doccheck@sgs.com](mailto:CN.Doccheck@sgs.com)

SGS-CSTC Standards Technical Services Co., Ltd.  
Shenzhen Branch Testing and Calibration Laboratory

Room 105, Building A, Xixiang Technology Industrial Park, No. 30 Fenggang Road, Xixiang Community, Fuyong Street, Bao'an District, Shenzhen, China 518103 t (86-755) 26012053 f (86-755) 26710594 www.sgs.com.cn  
中国·深圳·宝安区福永街道新田社区凤塘大道50号鑫龙科技园A栋105室 邮编: 518103 t (86-755) 26012053 f (86-755) 26710594 sgs.china@sgs.com

## SGS-CSTC Standards Technical Services Co., Ltd. Shenzhen Branch

SZEMC-TRF-01 Rev. A/0 Aug01,2022

Report No.: SZEM220800563801

Page: 5 of 54

7.3.3	Test Mode Description.....	40
7.3.4	Test Condition and Results:.....	40
8	TEST SETUP PHOTO.....	41
9	EUT CONSTRUCTIONAL DETAILS (EUT PHOTOS) .....	49



SGS-CSTC Standards Technical Services Co., Ltd.  
Shenzhen Branch Testing & Calibration Laboratory

Unless otherwise agreed in writing, this document is issued by the Company subject to its General Conditions of Service printed overleaf, available on request or accessible at <http://www.sgs.com/en/Terms-and-Conditions.aspx> and, for electronic format documents, subject to Terms and Conditions for Electronic Documents at <http://www.sgs.com/en/Terms-and-Conditions/Terms-e-Documents.aspx>. Attention is drawn to the limitation of liability, indemnification and jurisdiction issues defined therein. Any holder of this document is advised that information contained hereon reflects the Company's findings at the time of its intervention only and within the limits of Client's instructions, if any. The Company's sole responsibility is to its Client and this document does not exonerate parties to a transaction from exercising all their rights and obligations under the transaction documents. This document cannot be reproduced except in full, without prior written approval of the Company. Any unauthorized alteration, forgery or falsification of the content or appearance of this document is unlawful and offenders may be prosecuted to the fullest extent of the law. Unless otherwise stated the results shown in this test report refer only to the sample(s) tested and such sample(s) are retained for 30 days only.  
**Attention: To check the authenticity of testing /inspection report & certificate, please contact us at telephone: (86-755) 8307 1443, or email: [CN.Doccheck@sgs.com](mailto:CN.Doccheck@sgs.com)**

Room 105, Building A, Xixiang Technology Industrial Park, No. 30 Fengtang Road, Xixiang Community, Fuyong Street, Bao'an District, Shenzhen, China 518103 t (86-755) 26012053 f (86-755) 26710594 www.sgs.com.cn  
中国·深圳·宝安区福永街道新田社区凤塘大道50号鑫龙科技工业园A栋105室 邮编: 518103 t (86-755) 26012053 f (86-755) 26710594 sgs.china@sgs.com

## 4 General Information

### 4.1 Details of E.U.T.

Power supply:	DC12V/24V
---------------	-----------

Remark: The information in this section is provided by the applicant or manufacturer, SGS is not liable to the accuracy, suitability, reliability or/and integrity of the information.

### 4.2 Description of Support Units

Description	Manufacturer	Model No.	Serial No.
--	--	--	--

The EUT has been tested as an independent unit.

### 4.3 Measurement Uncertainty

Test Item	Measurement Uncertainty
Radiated Emission(30MHz-1GHz)	±4.5dB
Conducted transient immunity	±5%

Remark:

The  $U_{lab}$  (lab Uncertainty) is less than  $U_{CISPR/ETSI}$  (CISPR/ETSI Uncertainty), so the test results

- compliance is deemed to occur if no measured disturbance level exceeds the disturbance limit;
- non-compliance is deemed to occur if any measured disturbance level exceeds the disturbance limit.



### 4.4 Test Location

All tests were performed at:

SGS-CSTC Standards Technical Services Co., Ltd., Shenzhen Branch

Room 105, Building A, Xinlong Technology Industrial Park, No. 50 Fengtang Road, Xintian Community, Fuyong Street, Bao'an District, Shenzhen, China

Tel: +86 755 2601 2053 Fax: +86 755 2671 0594

No tests were sub-contracted.

### 4.5 Test Facility

The test facility is recognized, certified, or accredited by the following organizations:

- **A2LA (Certificate No. 3816.01)**

SGS-CSTC Standards Technical Services Co., Ltd., Shenzhen EMC Laboratory is accredited by the American Association for Laboratory Accreditation(A2LA). Certificate No. 3816.01.

- **Innovation, Science and Economic Development Canada**

SGS-CSTC Standards Technical Services Co., Ltd., Shenzhen EMC Laboratory has been recognized by ISED as an accredited testing laboratory.

CAB identifier: CN0006.

IC#: 4620C.

### 4.6 Deviation from Standards

None

### 4.7 Abnormalities from Standard Conditions

None

### 4.8 EMS Monitor

Visual: Monitored the work status of the EUT



Unless otherwise agreed in writing, this document is issued by the Company subject to its General Conditions of Service printed overleaf, available on request or accessible at <http://www.sgs.com/en/Terms-and-Conditions.aspx> and, for electronic format documents, subject to Terms and Conditions for Electronic Documents at <http://www.sgs.com/en/Terms-and-Conditions/Terms-e-Documents.aspx>. Attention is drawn to the limitation of liability, indemnification and jurisdiction issues defined therein. Any holder of this document is advised that information contained hereon reflects the Company's findings at the time of its intervention only and within the limits of Client's instructions, if any. The Company's sole responsibility is to its Client and this document does not exonerate parties to a transaction from exercising all their rights and obligations under the transaction documents. This document cannot be reproduced except in full, without prior written approval of the Company. Any unauthorized alteration, forgery or falsification of the content or appearance of this document is unlawful and offenders may be prosecuted to the fullest extent of the law. Unless otherwise stated the results shown in this test report refer only to the sample(s) tested and such sample(s) are retained for 30 days only.  
**Attention: To check the authenticity of testing /inspection report & certificate, please contact us at telephone: (86-755) 8307 1443, or email: CN.Doccheck@sgs.com**

SGS-CSTC Standards Technical Services Co., Ltd.  
Shenzhen Branch EMC Laboratory

Room 105, Building A, Xinlong Technology Industrial Park, No. 50 Fengtang Road, Xintian Community, Fuyong Street, Bao'an District, Shenzhen, China 518103 t (86-755) 26012053 f (86-755) 26710594 www.sgs.com.cn  
中国·深圳·宝安区福永街道新田社区凤塘大道50号鑫龙科技工业园A栋105室 邮编: 518103 t (86-755) 26012053 f (86-755) 26710594 sgs.china@sgs.com

## 5 Equipment List

Radiated Emission(30MHz-1GHz)					
Equipment	Manufacturer	Model No	Inventory No	Cal Date	Cal Due Date
764 Anechoic Chamber	CRT	N/A	SEM001-12	2019-10-10	2022-10-09
Measurement Software	Rohde & Schwarz	EMC 32 V10.01.00	N/A	N/A	N/A
Coaxial Cable	SGS	N/A	SEM034-01	2022-05-16	2023-05-15
Biconical Antenna	Schwarzebeck	VHBB9124	SEM003-27	2021-10-17	2022-10-16
Log.-Per. Antenna	Schwarzebeck	VUSLP9111B	SEM003-28	2021-10-17	2022-10-16
Amplifier	Sonoma Instrument Co	310N	SEM005-03	2022-04-06	2023-04-05
EMI Test Receiver	Rohde & Schwarz	ESR	SEM004-03	2022-03-23	2023-03-22
LISN	Schwarzebeck	NNBM8124- 200	SEM007-20	2021-10-26	2022-10-25
LISN	Schwarzebeck	NNBM8124- 200	SEM007-21	2021-10-26	2022-10-25

Conducted transient disturbances					
Equipment	Manufacturer	Model No	Inventory No	Cal Date	Cal Due Date
Oscilloscope	Tektronix	MSO 4104	SEM022-02	2021-09-15	2022-09-14
Switch	EM TEST	BS 200B	SEM018-07	2021-09-18	2022-09-17
LISN	Schwarzebeck	NNBM8125	SEM007-18	2021-09-18	2022-09-17

Conducted transient immunity					
Equipment	Manufacturer	Model No	Inventory No	Cal Date	Cal Due Date
Automotive Transient Test System	Noiseken	ISS 7600	SEM050-13	2022-04-06	2023-04-05
DC Power supply	Noiseken	BP4610	SEM050-15	2022-04-06	2023-04-05
Measurement Software	EM Test/AG	ISMISO for windows V4.21	N/A	N/A	N/A
Oscilloscope	Tektronix	MSO 4104	SEM022-02	2021-09-15	2022-09-14



<b>Bulk Current Injection(20MHz-400MHz)</b>					
Equipment	Manufacturer	Model No	Inventory No	Cal Date	Cal Due Date
Measurement Software	NEXIO	BAT V3.19.1.9	N/A	N/A	N/A
LISN	Schwarzebeck	NNBM8125	SEM007-18	2021-09-18	2022-09-17
LISN	Schwarzebeck	NNBM8125	SEM007-19	2021-09-18	2022-09-17
RF generator and power meter	TESEQ	NSG 4070C-0	SEM006-18	2021-10-26	2022-10-25
Bulk Current injection	FCC	F-130A-1	SEM013-05	2021-10-26	2022-10-25
BCI Calibration Fixture	FCC	FCC-BCICF-1	SEM013-06	2021-10-26	2022-10-25
Dual directional coupler	Werlatone	C5339	SEM021-11	2021-10-26	2022-10-25
BCI Cable Output	Huber Suhner	N/A	SEM036-01	2022-05-16	2023-05-15
BCI Cable Input	Huber Suhner	N/A	SEM036-02	2022-05-16	2023-05-15
RF Generator And Power Meter	TESEQ	NSG 4070C-0	SEM006-18	2021-10-26	2022-10-25
Coupling/Decoupling Network	SCHLODER	CDN M2+3	SEM007-17	2022-04-07	2023-04-06
Solid State Amplifier	TESEQ	CBA 400M-110	SEM005-22	2021-10-26	2022-10-25

<b>Radiation immunity-ALSE(400MHz-2GHz)</b>					
Equipment	Manufacturer	Model No	Inventory No	Cal Date	Cal Due Date
764 Anechoic Chamber	CRT	N/A	SEM001-12	2019-10-10	2022-10-09
LISN	Schwarzebeck	NNBM8124-200	SEM007-20	2021-10-26	2022-10-25
LISN	Schwarzebeck	NNBM8124-200	SEM007-21	2021-10-26	2022-10-25
Measurement Software	NEXIO	BAT V3.19.1.20	N/A	N/A	N/A
Solid State Amplifier	TESEQ	CBA 1G-1200B	SEM005-20	2021-10-26	2022-10-25
Solid State Amplifier	TESEQ	CBA 6G-200D	SEM005-21	2022-06-24	2023-06-23
USB Power Sensor	Keysight	U2042XA	SEM009-18	2021-10-26	2022-10-25
USB Power Sensor	Keysight	U2042XA	SEM009-19	2021-10-26	2022-10-25
MXG Analog Signal Generator	Agilent	N5181A	SEM006-16	2021-09-15	2022-09-14
Log.-Per. Antenna	Schwarzbeck	STLP 9128 Esp-7/16	SEM003-29	N/A	N/A
Broadband Horn Antenna	Schwarzbeck	BBHA 9120J	SEM003-30	N/A	N/A
RI Cable	Huber Suhner	N/A	SEM034-02	2022-05-16	2023-05-15
RI Cable	Huber Suhner	N/A	SEM034-03	2022-05-16	2023-05-15



Unless otherwise agreed in writing, this document is issued by the Company subject to its General Conditions of Service printed overleaf, available on request or accessible at <http://www.sgs.com/en/Terms-and-Conditions.aspx> and, for electronic format documents, subject to Terms and Conditions for Electronic Documents at <http://www.sgs.com/en/Terms-and-Conditions/Terms-e-Documents.aspx>. Attention is drawn to the limitation of liability, indemnification and jurisdiction issues defined therein. Any holder of this document is advised that information contained hereon reflects the Company's findings at the time of its intervention only and within the limits of Client's instructions, if any. The Company's sole responsibility is to its Client and this document does not exonerate parties to a transaction from exercising all their rights and obligations under the transaction documents. This document cannot be reproduced except in full, without prior written approval of the Company. Any unauthorized alteration, forgery or falsification of the content or appearance of this document is unlawful and offenders may be prosecuted to the fullest extent of the law. Unless otherwise stated the results shown in this test report refer only to the sample(s) tested and such sample(s) are retained for 30 days only.

Attention: To check the authenticity of testing/inspection report & certificate, please contact us at telephone: (86-755) 8307 1443, or email: [CN.Doccheck@sgs.com](mailto:CN.Doccheck@sgs.com)

Room 105, Building A, Xixiang Technology Industrial Park, No. 30 Fenggang Road, Xixiang Community, Fuyong Street, Bao'an District, Shenzhen, China 518103 t (86-755) 26012053 f (86-755) 26710594 www.sgs.com.cn  
 中国·深圳·宝安区福永街道新田社区凤塘大道30号鑫龙科技园栋105室 邮编: 518103 t (86-755) 26012053 f (86-755) 26710594 sgs.china@sgs.com

# SGS-CSTC Standards Technical Services Co., Ltd. Shenzhen Branch

SZEMC-TRF-01 Rev. A/0 Aug01,2022

Report No.: SZEM220800563801

Page: 10 of 54

General used equipment					
Equipment	Manufacturer	Model No.	Inventory No.	Cal Date	Cal Due Date
Humidity/ Temperature Indicator	MINGGAO	TH607	SEM002-18	2021-09-14	2022-09-13
Humidity/ Temperature Indicator	MINGGAO	TH607	SEM002-19	2021-09-14	2022-09-13
Humidity/ Temperature Indicator	MINGGAO	TH607	SEM002-20	2021-09-14	2022-09-13
Barometer	Shanghai Meteorological Industry Factory	DYM3	SEM002-24	2021-09-14	2022-09-13



SGS-CSTC Standards Technical Services Co., Ltd.  
Shenzhen Branch Testing & Calibration Laboratory

Unless otherwise agreed in writing, this document is issued by the Company subject to its General Conditions of Service printed overleaf, available on request or accessible at <http://www.sgs.com/en/Terms-and-Conditions.aspx> and, for electronic format documents, subject to Terms and Conditions for Electronic Documents at <http://www.sgs.com/en/Terms-and-Conditions/Terms-e-Documents.aspx>. Attention is drawn to the limitation of liability, indemnification and jurisdiction issues defined therein. Any holder of this document is advised that information contained hereon reflects the Company's findings at the time of its intervention only and within the limits of Client's instructions, if any. The Company's sole responsibility is to its Client and this document does not exonerate parties to a transaction from exercising all their rights and obligations under the transaction documents. This document cannot be reproduced except in full, without prior written approval of the Company. Any unauthorized alteration, forgery or falsification of the content or appearance of this document is unlawful and offenders may be prosecuted to the fullest extent of the law. Unless otherwise stated the results shown in this test report refer only to the sample(s) tested and such sample(s) are retained for 30 days only.  
Attention: To check the authenticity of testing /inspection report & certificate, please contact us at telephone: (86-755) 8307 1443, or email: [CN.Doccheck@sgs.com](mailto:CN.Doccheck@sgs.com)

Room 105, Building A, Xixiang Technology Industrial Park, No. 50 Fengtang Road, Xixiang Community, Fuyong Street, Bao'an District, Shenzhen, China 518103 t (86-755) 26012053 f (86-755) 26710594 www.sgs.com.cn  
中国·深圳·宝安区福永街道新田社区凤塘大道50号鑫龙科技工业园A栋105室 邮编: 518103 t (86-755) 26012053 f (86-755) 26710594 sgs.china@sgs.com

### 6 Emission Test Results

#### 6.1 Radiated Emission(30MHz-1GHz)

Test Requirement: ECE R10.06  
 Test Method: CISPR 25:2002  
 Frequency Range: 30MHz to 1GHz  
 Measurement Distance: 1m  
 Limit:

Radiated Emission (Broadband Type) Limit for ESA

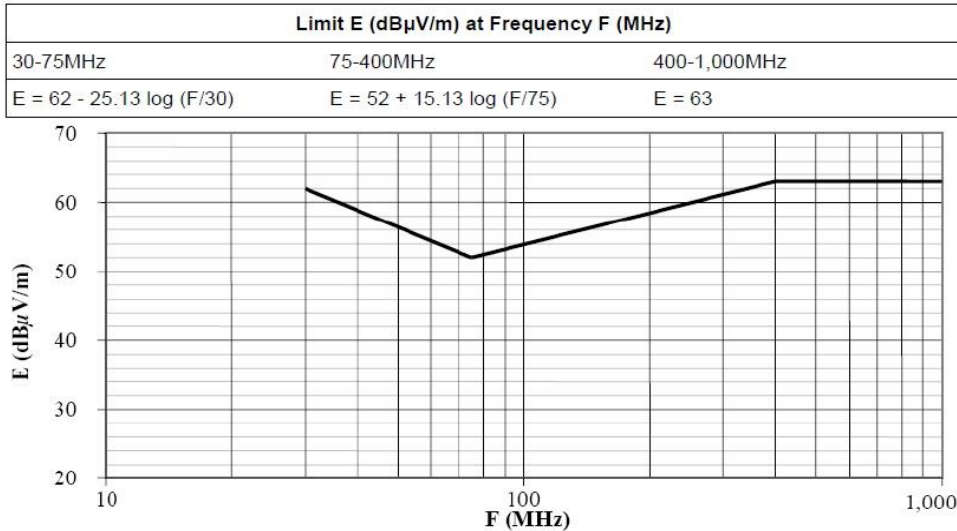

Radiated Emission (Narrowband Type) Limit for ESA

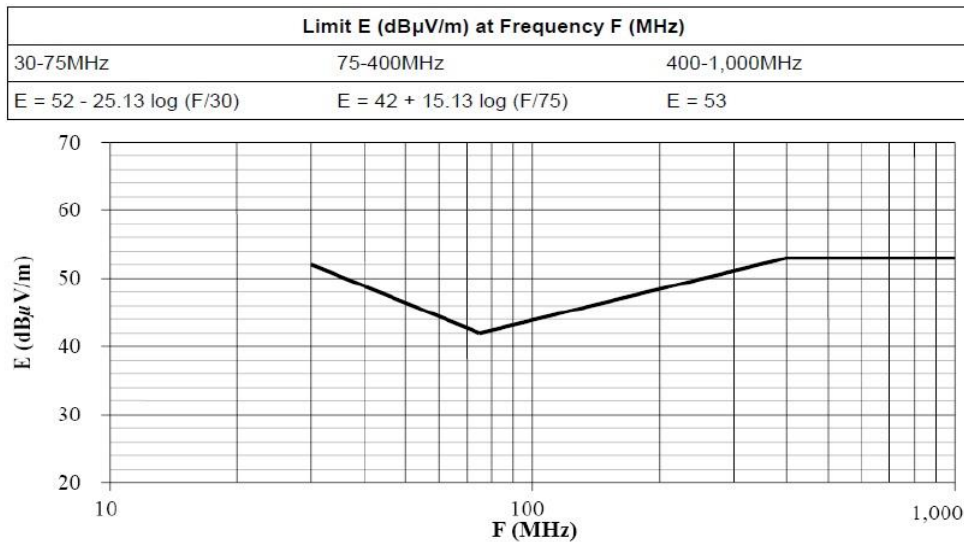

## SGS-CSTC Standards Technical Services Co., Ltd. Shenzhen Branch

SZEMC-TRF-01 Rev. A/0 Aug01,2022

Report No.: SZEM220800563801

Page: 12 of 54

### 6.1.1 E.U.T. Operation

Operating Environment:

Temperature: 22.6 °C Humidity: 52.0 % RH Atmospheric Pressure: 1015 mbar

### 6.1.2 Test Mode Description

Pre-scan / Final test	Mode Code	Description
Final test	00	DC 13.5V Power Supply_Keep EUT working normally.
Pre-scan	01	DC 27V Power Supply_Keep EUT working normally.



SGS-CSTC Standards Technical Services Co., Ltd.  
Shenzhen Branch Testing & ETC Laboratory

Unless otherwise agreed in writing, this document is issued by the Company subject to its General Conditions of Service printed overleaf, available on request or accessible at <http://www.sgs.com/en/Terms-and-Conditions.aspx> and, for electronic format documents, subject to Terms and Conditions for Electronic Documents at <http://www.sgs.com/en/Terms-and-Conditions/Terms-e-Documents.aspx>. Attention is drawn to the limitation of liability, indemnification and jurisdiction issues defined therein. Any holder of this document is advised that information contained hereon reflects the Company's findings at the time of its intervention only and within the limits of Client's instructions, if any. The Company's sole responsibility is to its Client and this document does not exonerate parties to a transaction from exercising all their rights and obligations under the transaction documents. This document cannot be reproduced except in full, without prior written approval of the Company. Any unauthorized alteration, forgery or falsification of the content or appearance of this document is unlawful and offenders may be prosecuted to the fullest extent of the law. Unless otherwise stated the results shown in this test report refer only to the sample(s) tested and such sample(s) are retained for 30 days only.  
Attention: To check the authenticity of testing /inspection report & certificate, please contact us at telephone: (86-755) 8307 1443, or email: [CN.Doccheck@sgs.com](mailto:CN.Doccheck@sgs.com)

Room 105, Building A, Xixiang Technology Industrial Park, No. 30 Fengtang Road, Xixiang Community, Fuyong Street, Bao'an District, Shenzhen, China 518103 t (86-755) 26012053 f (86-755) 26710594 www.sgs.com.cn  
中国·深圳·宝安区福永街道新田社区凤塘大道50号鑫龙科技工业园A栋105室 邮编: 518103 t (86-755) 26012053 f (86-755) 26710594 sgs.china@sgs.com

### 6.1.3 Test Setup Diagram

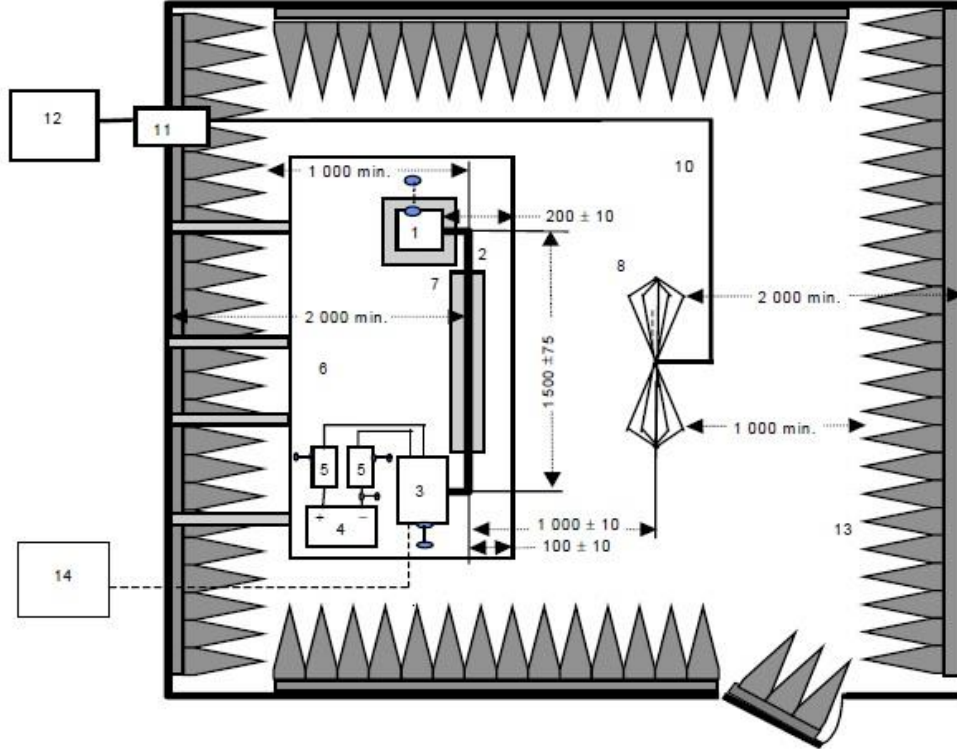

#### Key

1. EUT (grounded locally if required in test plan)	8. Biconical antenna
2. Test harness	10. High-quality coaxial cable
3. Load simulator	11. Bulkhead connector
4. Power supply (location optional)	12. Measuring instrument
5. Artificial network (AN)	13. RF absorber material
6. Ground plane (bonded to shielded enclosure)	14. Stimulation and monitoring system
7. Low relative permittivity support	

Figure – Example of test set-up – Biconical antenna

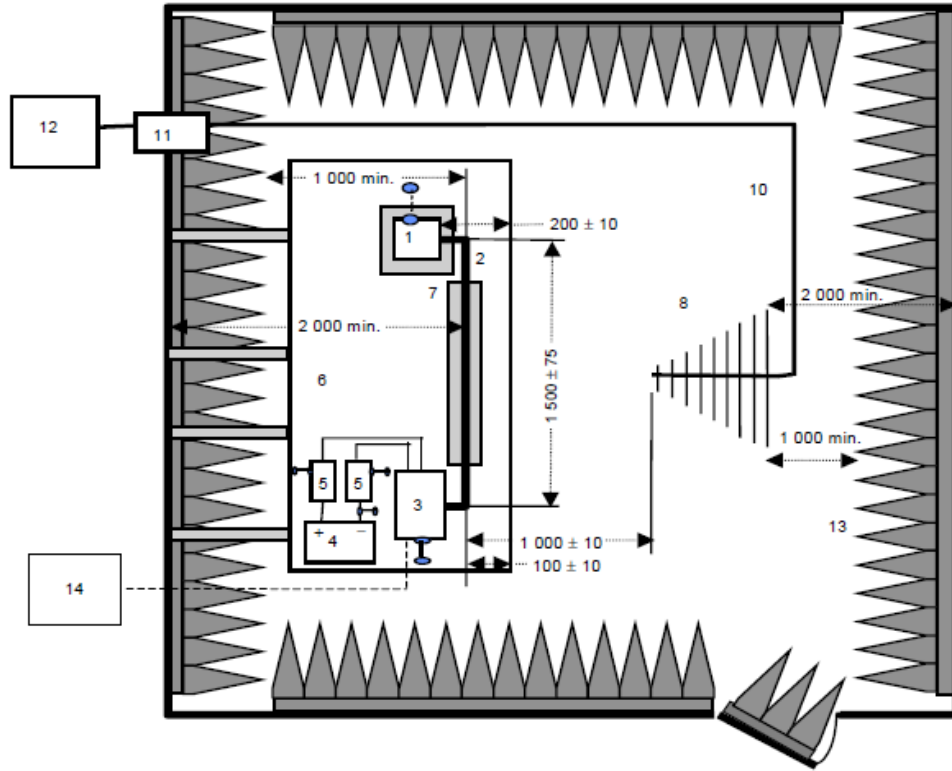

### Key

1. EUT (grounded locally if required in test plan)	8. Log-periodic antenna
2. Test harness	10. High-quality coaxial cable
3. Load simulator	11. Bulkhead connector
4. Power supply (location optional)	12. Measuring instrument
5. Artificial network (AN)	13. RF absorber material
6. Ground plane (bonded to shielded enclosure)	14. Stimulation and monitoring system
7. Low relative permittivity support	

Figure – Example of test set-up – Log-periodic antenna

### 6.1.4 Measurement Procedure and Data

Frequency Range:30MHz-1GHz



Unless otherwise agreed in writing, this document is issued by the Company subject to its General Conditions of Service printed overleaf, available on request or accessible at <http://www.sgs.com/en/Terms-and-Conditions.aspx> and, for electronic format documents, subject to Terms and Conditions for Electronic Documents at <http://www.sgs.com/en/Terms-and-Conditions/Terms-e-Documents.aspx>. Attention is drawn to the limitation of liability, indemnification and jurisdiction issues defined therein. Any holder of this document is advised that information contained hereon reflects the Company's findings at the time of its intervention only and within the limits of Client's instructions, if any. The Company's sole responsibility is to its Client and this document does not exonerate parties to a transaction from exercising all their rights and obligations under the transaction documents. This document cannot be reproduced except in full, without prior written approval of the Company. Any unauthorized alteration, forgery or falsification of the content or appearance of this document is unlawful and offenders may be prosecuted to the fullest extent of the law. Unless otherwise stated the results shown in this test report refer only to the sample(s) tested and such sample(s) are retained for 30 days only.  
**Attention: To check the authenticity of testing /inspection report & certificate, please contact us at telephone: (86-755) 8307 1443, or email: CN.Doccheck@sgs.com**

SGS-CSTC Standards Technical Services Co., Ltd.  
 Shenzhen Branch Testing Laboratory

Room 105, Building A, Xixiang Technology Industrial Park, No. 50 Fengtang Road, Xixiang Community, Fuyong Street, Bao'an District, Shenzhen, China 518103 t (86-755) 26012053 f (86-755) 26710594 www.sgsgroup.com.cn  
 中国·深圳·宝安区福永街道新田社区凤塘大道50号鑫龙科技园A栋105室 邮编: 518103 t (86-755) 26012053 f (86-755) 26710594 sgs.china@sgs.com

Test Mode: 00 Polarity: Horizontal; 30-200MHz; Detector: QP

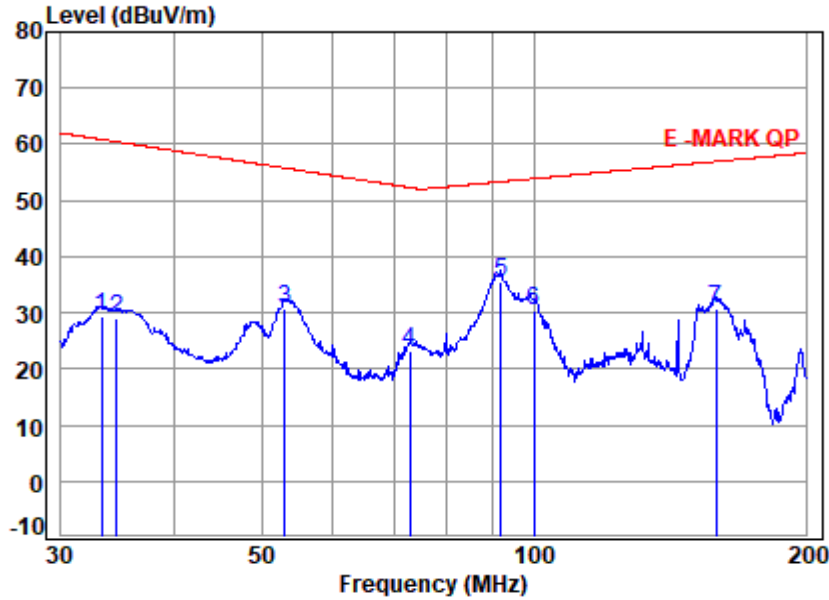

Condition: 1m Horizontal

Job No : 05638AU

Mode : 00

	Freq	Cable Loss	Ant Factor	Preamplifier	Read Level	Limit Level	Limit Line	Over Limit	Remark
	MHz	dB	dB/m	dB	dBuV	dBuV/m	dBuV/m	dB	
1	33.2363	0.40	12.64	32.60	48.77	29.21	60.88	-31.67	QP
2	34.5871	0.40	12.65	32.60	48.42	28.87	60.45	-31.58	QP
3	53.0022	0.51	11.22	32.59	51.43	30.57	55.79	-25.22	QP
4	73.0356	0.62	9.94	32.55	45.23	23.24	52.29	-29.05	QP
5 pp	92.0558	0.72	10.21	32.51	57.03	35.45	53.35	-17.90	QP
6	100.0699	0.77	10.60	32.50	51.42	30.29	53.90	-23.61	QP
7	158.9780	1.02	14.34	32.57	47.86	30.65	56.94	-26.29	QP



Unless otherwise agreed in writing, this document is issued by the Company subject to its General Conditions of Service printed overleaf, available on request or accessible at <http://www.sgs.com/en/Terms-and-Conditions.aspx> and, for electronic format documents, subject to Terms and Conditions for Electronic Documents at <http://www.sgs.com/en/Terms-and-Conditions/Terms-e-Documents.aspx>. Attention is drawn to the limitation of liability, indemnification and jurisdiction issues defined therein. Any holder of this document is advised that information contained hereon reflects the Company's findings at the time of its intervention only and within the limits of Client's instructions, if any. The Company's sole responsibility is to its Client and this document does not exonerate parties to a transaction from exercising all their rights and obligations under the transaction documents. This document cannot be reproduced except in full, without prior written approval of the Company. Any unauthorized alteration, forgery or falsification of the content or appearance of this document is unlawful and offenders may be prosecuted to the fullest extent of the law. Unless otherwise stated the results shown in this test report refer only to the sample(s) tested and such sample(s) are retained for 30 days only. Attention: To check the authenticity of testing /inspection report & certificate, please contact us at telephone: (86-755) 8307 1443, or email: [CN.Doccheck@sgs.com](mailto:CN.Doccheck@sgs.com)

Room 105, Building A, Xixiang Technology Industrial Park, No. 30 Fengyang Road, Xixiang Community, Fuyong Street, Bao'an District, Shenzhen, China 518103 t (86-755) 26012053 f (86-755) 26710594 www.sgs.com  
 中国·深圳·宝安区福永街道新田社区凤塘大道30号鑫龙科技园A栋105室 邮编: 518103 t (86-755) 26012053 f (86-755) 26710594 sgs.china@sgs.com

Test Mode: 00 Polarity: Horizontal; 30-200MHz; Detector: AV

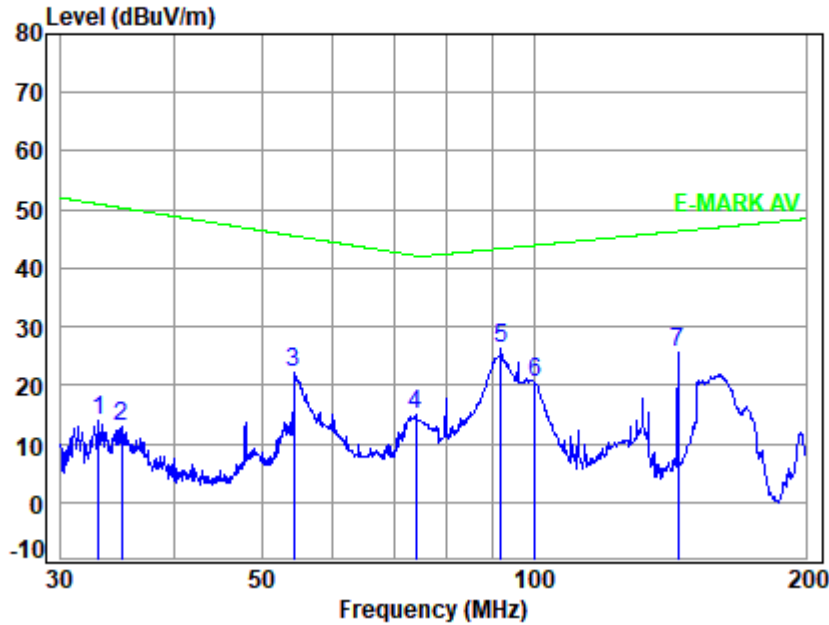

Condition: 1m Horizontal

Job No : 05638AU

Mode : 00

	Freq	Cable Loss	Ant Factor	Preamp Factor	Read Level	Level	Limit	Over	Remark
	MHz	dB	dB/m	dB	dBuV	dBuV/m	dBuV/m	dB	
1	32.9850	0.40	12.63	32.60	33.53	13.96	50.96	-37.00	Average
2	35.0495	0.40	12.65	32.60	32.33	12.78	50.30	-37.52	Average
3	54.3256	0.52	11.05	32.59	43.24	22.22	45.52	-23.30	Average
4	74.0120	0.63	9.92	32.54	36.84	14.85	42.14	-27.29	Average
5 pp	92.0558	0.72	10.21	32.51	47.75	26.17	43.35	-17.18	Average
6	100.2599	0.77	10.61	32.50	41.58	20.46	43.91	-23.45	Average
7	144.3171	0.96	13.69	32.55	43.65	25.75	46.30	-20.55	Average



Unless otherwise agreed in writing, this document is issued by the Company subject to its General Conditions of Service printed overleaf, available on request or accessible at <http://www.sgs.com/en/Terms-and-Conditions.aspx> and, for electronic format documents, subject to Terms and Conditions for Electronic Documents at <http://www.sgs.com/en/Terms-and-Conditions/Terms-e-Documents.aspx>. Attention is drawn to the limitation of liability, indemnification and jurisdiction issues defined therein. Any holder of this document is advised that information contained hereon reflects the Company's findings at the time of its intervention only and within the limits of Client's instructions, if any. The Company's sole responsibility is to its Client and this document does not exonerate parties to a transaction from exercising all their rights and obligations under the transaction documents. This document cannot be reproduced except in full, without prior written approval of the Company. Any unauthorized alteration, forgery or falsification of the content or appearance of this document is unlawful and offenders may be prosecuted to the fullest extent of the law. Unless otherwise stated the results shown in this test report refer only to the sample(s) tested and such sample(s) are retained for 30 days only. Attention: To check the authenticity of testing /inspection report & certificate, please contact us at telephone: (86-755) 8307 1443, or email: [CN.Doccheck@sgs.com](mailto:CN.Doccheck@sgs.com)

Test Mode: 00 Polarity: Vertical; 30-200MHz; Detector: QP

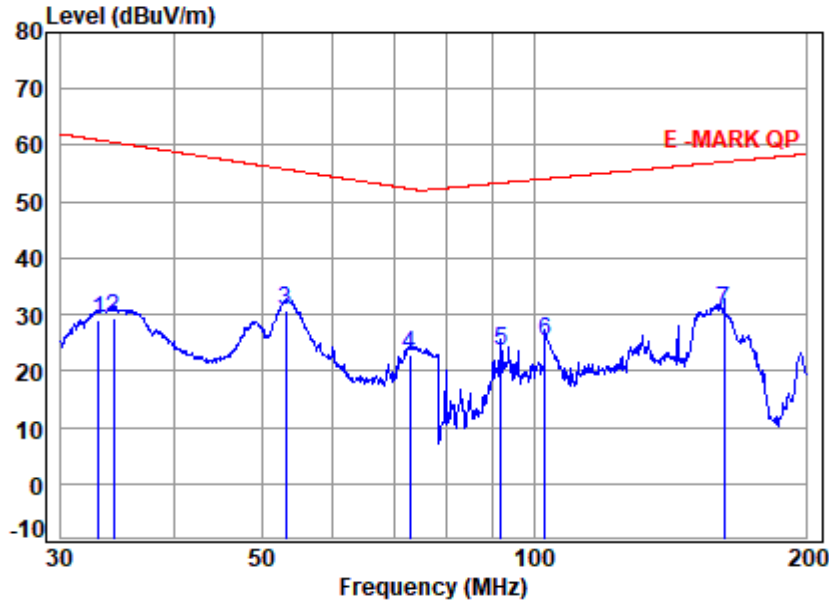

Condition: 1m Vertical  
 Job No : 05638AU  
 Mode : 00

	Freq	Cable Loss	Ant Factor	Preamp Factor	Read Level	Level	Limit Line	Over Limit	Remark
	MHz	dB	dB/m	dB	dBuV	dBuV/m	dBuV/m	dB	
1	33.0477	0.40	12.63	32.60	48.45	28.88	60.94	-32.06	QP
2	34.3257	0.40	12.65	32.60	48.97	29.42	60.53	-31.11	QP
3 pp	53.2037	0.51	11.19	32.59	51.53	30.64	55.75	-25.11	QP
4	73.0356	0.62	9.94	32.55	44.89	22.90	52.29	-29.39	QP
5	92.0558	0.72	10.21	32.51	45.02	23.44	53.35	-29.91	QP
6	102.9584	0.78	10.72	32.50	46.25	25.25	54.08	-28.83	QP
7	162.6387	1.03	14.53	32.57	47.69	30.68	57.09	-26.41	QP



Unless otherwise agreed in writing, this document is issued by the Company subject to its General Conditions of Service printed overleaf, available on request or accessible at <http://www.sgs.com/en/Terms-and-Conditions.aspx> and, for electronic format documents, subject to Terms and Conditions for Electronic Documents at <http://www.sgs.com/en/Terms-and-Conditions/Terms-e-Documents.aspx>. Attention is drawn to the limitation of liability, indemnification and jurisdiction issues defined therein. Any holder of this document is advised that information contained hereon reflects the Company's findings at the time of its intervention only and within the limits of Client's instructions, if any. The Company's sole responsibility is to its Client and this document does not exonerate parties to a transaction from exercising all their rights and obligations under the transaction documents. This document cannot be reproduced except in full, without prior written approval of the Company. Any unauthorized alteration, forgery or falsification of the content or appearance of this document is unlawful and offenders may be prosecuted to the fullest extent of the law. Unless otherwise stated the results shown in this test report refer only to the sample(s) tested and such sample(s) are retained for 30 days only.  
 Attention: To check the authenticity of testing /inspection report & certificate, please contact us at telephone: (86-755) 8307 1443, or email: [CN.Doccheck@sgs.com](mailto:CN.Doccheck@sgs.com)

SGS-CSTC Standards Technical Services Co., Ltd.  
 Shenzhen Branch Testing & Calibration Laboratory

Room 105, Building A, Xixiang Technology Industrial Park, No. 30 Fengyang Road, Xixiang Community, Fuyong Street, Bao'an District, Shenzhen, China 518103 t (86-755) 26012053 f (86-755) 26710594 www.sgs.com  
 中国·深圳·宝安区福永街道新田社区凤塘大道30号鑫龙科技园A栋105室 邮编: 518103 t (86-755) 26012053 f (86-755) 26710594 sgs.china@sgs.com

Test Mode: 00 Polarity: Vertical; 30-200MHz; Detector: AV

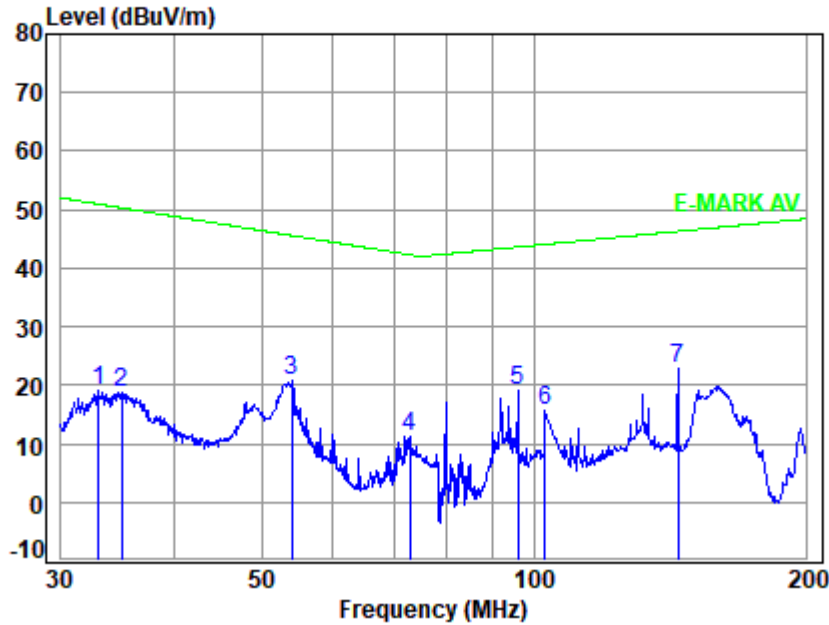

Condition: 1m Vertical

Job No : 05638AU

Mode : 00

	Freq	Cable Loss	Ant Factor	Preamp Factor	Read Level	Level	Limit Line	Over Limit	Remark
	MHz	dB	dB/m	dB	dBuV	dBuV/m	dBuV/m	dB	
1	32.9850	0.40	12.63	32.60	38.69	19.12	50.96	-31.84	Average
2	35.0495	0.40	12.65	32.60	38.41	18.86	50.30	-31.44	Average
3	54.0173	0.51	11.09	32.59	41.73	20.74	45.58	-24.84	Average
4	73.0356	0.62	9.94	32.55	33.20	11.21	42.29	-31.08	Average
5	95.9792	0.74	10.41	32.51	40.57	19.21	43.62	-24.41	Average
6	102.9584	0.78	10.72	32.50	36.58	15.58	44.08	-28.50	Average
7 pp	144.3171	0.96	13.69	32.55	40.59	22.69	46.30	-23.61	Average



Unless otherwise agreed in writing, this document is issued by the Company subject to its General Conditions of Service printed overleaf, available on request or accessible at <http://www.sgs.com/en/Terms-and-Conditions.aspx> and, for electronic format documents, subject to Terms and Conditions for Electronic Documents at <http://www.sgs.com/en/Terms-and-Conditions/Terms-e-Documents.aspx>. Attention is drawn to the limitation of liability, indemnification and jurisdiction issues defined therein. Any holder of this document is advised that information contained hereon reflects the Company's findings at the time of its intervention only and within the limits of Client's instructions, if any. The Company's sole responsibility is to its Client and this document does not exonerate parties to a transaction from exercising all their rights and obligations under the transaction documents. This document cannot be reproduced except in full, without prior written approval of the Company. Any unauthorized alteration, forgery or falsification of the content or appearance of this document is unlawful and offenders may be prosecuted to the fullest extent of the law. Unless otherwise stated the results shown in this test report refer only to the sample(s) tested and such sample(s) are retained for 30 days only. Attention: To check the authenticity of testing /inspection report & certificate, please contact us at telephone: (86-755) 8307 1443, or email: [CN.Doccheck@sgs.com](mailto:CN.Doccheck@sgs.com)

Test Mode: 00 Polarity: Horizontal; 200-1000MHz; Detector: QP

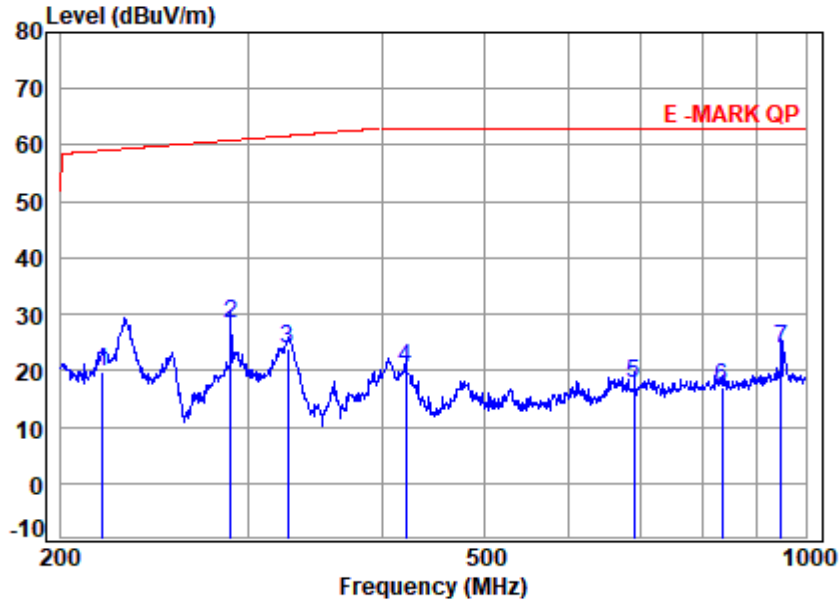

Condition: 1m Horizontal

Job No : 05638AU

mode : 00

	Freq	Cable Loss	Ant Factor	Preamp Factor	Read Level	Limit Level	Over Limit	Remark
	MHz	dB	dB/m	dB	dBuV	dBuV/m	dBuV/m	dB
1	218.8630	1.24	13.00	32.58	38.22	19.88	59.04	-39.16 QP
2	pp 288.6657	1.47	14.14	32.51	45.30	28.40	60.86	-32.46 QP
3	326.7502	1.58	14.60	32.47	40.10	23.81	61.67	-37.86 QP
4	421.3598	1.84	15.77	32.40	35.29	20.50	63.00	-42.50 QP
5	690.6164	2.48	18.39	32.31	29.25	17.81	63.00	-45.19 QP
6	835.0555	2.79	19.71	31.98	26.61	17.13	63.00	-45.87 QP
7	948.2743	3.02	20.68	31.15	31.19	23.74	63.00	-39.26 QP



Unless otherwise agreed in writing, this document is issued by the Company subject to its General Conditions of Service printed overleaf, available on request or accessible at <http://www.sgs.com/en/Terms-and-Conditions.aspx> and, for electronic format documents, subject to Terms and Conditions for Electronic Documents at <http://www.sgs.com/en/Terms-and-Conditions/Terms-e-Documents.aspx>. Attention is drawn to the limitation of liability, indemnification and jurisdiction issues defined therein. Any holder of this document is advised that information contained hereon reflects the Company's findings at the time of its intervention only and within the limits of Client's instructions, if any. The Company's sole responsibility is to its Client and this document does not exonerate parties to a transaction from exercising all their rights and obligations under the transaction documents. This document cannot be reproduced except in full, without prior written approval of the Company. Any unauthorized alteration, forgery or falsification of the content or appearance of this document is unlawful and offenders may be prosecuted to the fullest extent of the law. Unless otherwise stated the results shown in this test report refer only to the sample(s) tested and such sample(s) are retained for 30 days only.

Attention: To check the authenticity of testing /inspection report & certificate, please contact us at telephone: (86-755) 8307 1443, or email: [CN.Doccheck@sgs.com](mailto:CN.Doccheck@sgs.com)

SGS-CSTC Standards Technical Services Co., Ltd.  
Shenzhen Branch Testing & Calibration Laboratory

Room 105, Building A, Xixiang Technology Industrial Park, No. 30 Fengtang Road, Xixiang Community, Fuyong Street, Bao'an District, Shenzhen, China 518103 t (86-755) 26012053 f (86-755) 26710594 www.sgs.com  
中国·深圳·宝安区福永街道新田社区凤塘大道30号鑫龙科技园A栋105室 邮编: 518103 t (86-755) 26012053 f (86-755) 26710594 sgs.china@sgs.com

Test Mode: 00 Polarity: Horizontal; 200-1000MHz; Detector: AV

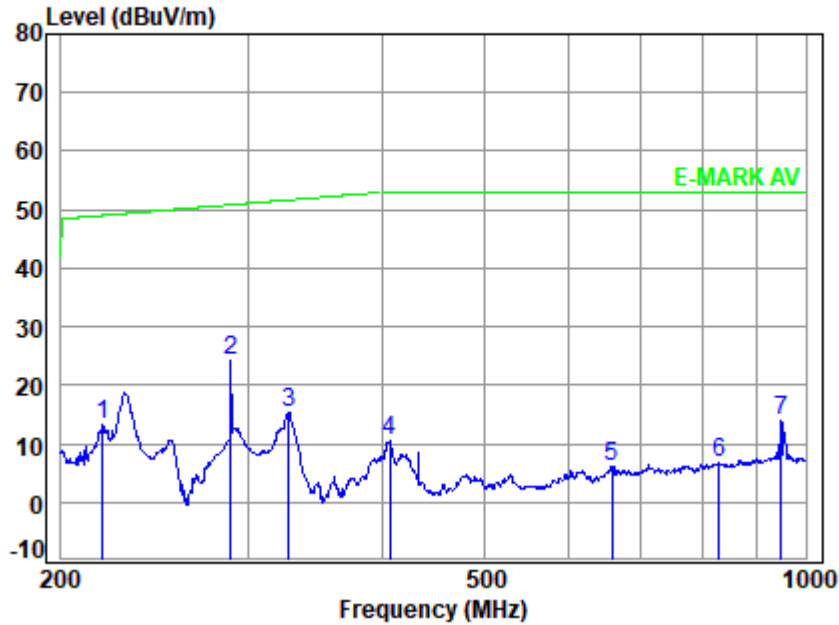

Condition: 1m Horizontal

Job No : 05638AU

mode : 00

	Freq	Cable Loss	Ant Factor	Preamp Factor	Read Level	Level	Limit Line	Over Limit	Remark
	MHz	dB	dB/m	dB	dBuV	dBuV/m	dBuV/m	dB	
1	218.8630	1.24	13.00	32.58	31.50	13.16	49.04	-35.88	Average
2	288.6657	1.47	14.14	32.51	40.96	24.06	50.86	-26.80	Average
3	327.2765	1.58	14.60	32.47	31.77	15.48	51.68	-36.20	Average
4	406.7015	1.81	15.86	32.40	25.09	10.36	53.00	-42.64	Average
5	658.0635	2.41	18.00	32.34	18.18	6.25	53.00	-46.75	Average
6	828.3627	2.78	19.67	32.02	16.19	6.62	53.00	-46.38	Average
7	948.2743	3.02	20.68	31.15	21.40	13.95	53.00	-39.05	Average



Unless otherwise agreed in writing, this document is issued by the Company subject to its General Conditions of Service printed overleaf, available on request or accessible at <http://www.sgs.com/en/Terms-and-Conditions.aspx> and, for electronic format documents, subject to Terms and Conditions for Electronic Documents at <http://www.sgs.com/en/Terms-and-Conditions/Terms-e-Documents.aspx>. Attention is drawn to the limitation of liability, indemnification and jurisdiction issues defined therein. Any holder of this document is advised that information contained hereon reflects the Company's findings at the time of its intervention only and within the limits of Client's instructions, if any. The Company's sole responsibility is to its Client and this document does not exonerate parties to a transaction from exercising all their rights and obligations under the transaction documents. This document cannot be reproduced except in full, without prior written approval of the Company. Any unauthorized alteration, forgery or falsification of the content or appearance of this document is unlawful and offenders may be prosecuted to the fullest extent of the law. Unless otherwise stated the results shown in this test report refer only to the sample(s) tested and such sample(s) are retained for 30 days only.  
**Attention:** To check the authenticity of testing /inspection report & certificate, please contact us at telephone: (86-755) 8307 1443, or email: [CN.Doccheck@sgs.com](mailto:CN.Doccheck@sgs.com)

SGS-CSTC Standards Technical Services Co., Ltd.  
 Shenzhen Branch Testing & Calibration Laboratory

Room 105, Building A, Xixiang Technology Industrial Park, No. 30 Fengtang Road, Xixiang Community, Fuyong Street, Bao'an District, Shenzhen, China 518103 t (86-755) 26012053 f (86-755) 26710594 www.sgs.com.cn  
 中国·深圳·宝安区福永街道新田社区凤塘大道30号鑫龙科技园A栋105室 邮编: 518103 t (86-755) 26012053 f (86-755) 26710594 sgs.china@sgs.com

Test Mode: 00 Polarity: Vertical; 200-1000MHz; Detector: QP

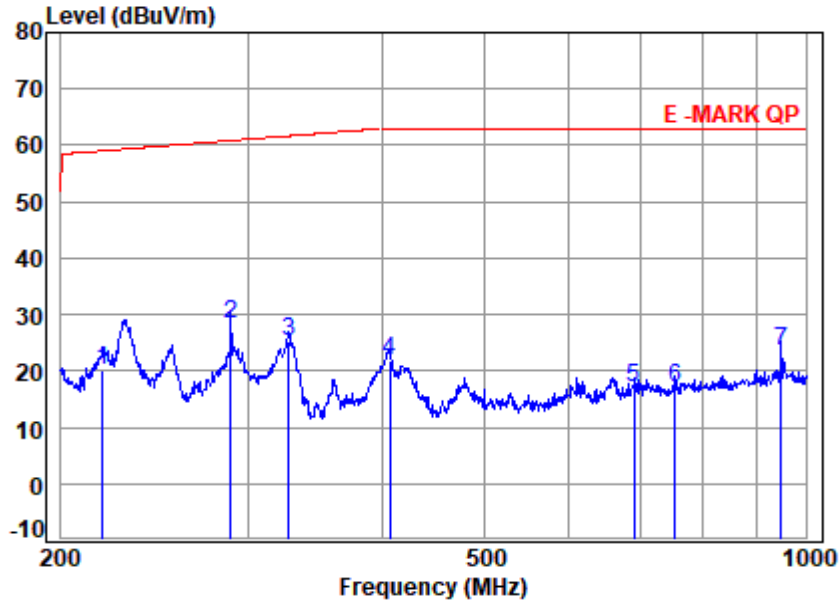

Condition: 1m Vertical  
 Job No : 05638AU  
 mode : 00

	Freq	Cable Loss	Ant Factor	Preamp Factor	Read Level	Level	Limit Line	Over Limit	Remark
	MHz	dB	dB/m	dB	dBuV	dBuV/m	dBuV/m	dB	
1	218.8630	1.24	13.00	32.58	38.49	20.15	59.04	-38.89	QP
2	pp 288.6657	1.47	14.14	32.51	45.17	28.27	60.86	-32.59	QP
3	327.2765	1.58	14.60	32.47	41.42	25.13	61.68	-36.55	QP
4	406.7015	1.81	15.86	32.40	36.68	21.95	63.00	-41.05	QP
5	690.6164	2.48	18.39	32.31	28.34	16.90	63.00	-46.10	QP
6	754.5365	2.62	19.14	32.24	27.65	17.17	63.00	-45.83	QP
7	948.2743	3.02	20.68	31.15	30.83	23.38	63.00	-39.62	QP



Unless otherwise agreed in writing, this document is issued by the Company subject to its General Conditions of Service printed overleaf, available on request or accessible at <http://www.sgs.com/en/Terms-and-Conditions.aspx> and, for electronic format documents, subject to Terms and Conditions for Electronic Documents at <http://www.sgs.com/en/Terms-and-Conditions/Terms-e-Documents.aspx>. Attention is drawn to the limitation of liability, indemnification and jurisdiction issues defined therein. Any holder of this document is advised that information contained hereon reflects the Company's findings at the time of its intervention only and within the limits of Client's instructions, if any. The Company's sole responsibility is to its Client and this document does not exonerate parties to a transaction from exercising all their rights and obligations under the transaction documents. This document cannot be reproduced except in full, without prior written approval of the Company. Any unauthorized alteration, forgery or falsification of the content or appearance of this document is unlawful and offenders may be prosecuted to the fullest extent of the law. Unless otherwise stated the results shown in this test report refer only to the sample(s) tested and such sample(s) are retained for 30 days only.  
 Attention: To check the authenticity of testing /inspection report & certificate, please contact us at telephone: (86-755) 8307 1443, or email: [CN.Doccheck@sgs.com](mailto:CN.Doccheck@sgs.com)

SGS-CSTC Standards Technical Services Co., Ltd.  
 Shenzhen Branch Testing & Calibration Laboratory

Room 105, Building A, Xixiang Technology Industrial Park, No. 50 Fengtang Road, Xixiang Community, Fuyong Street, Bao'an District, Shenzhen, China 518103 t (86-755) 26012053 f (86-755) 26710594 www.sgs.com  
 中国·深圳·宝安区福永街道新田社区凤塘大道50号鑫龙科技园A栋105室 邮编: 518103 t (86-755) 26012053 f (86-755) 26710594 sgs.china@sgs.com

Test Mode: 00 Polarity: Vertical; 200-1000MHz; Detector: AV

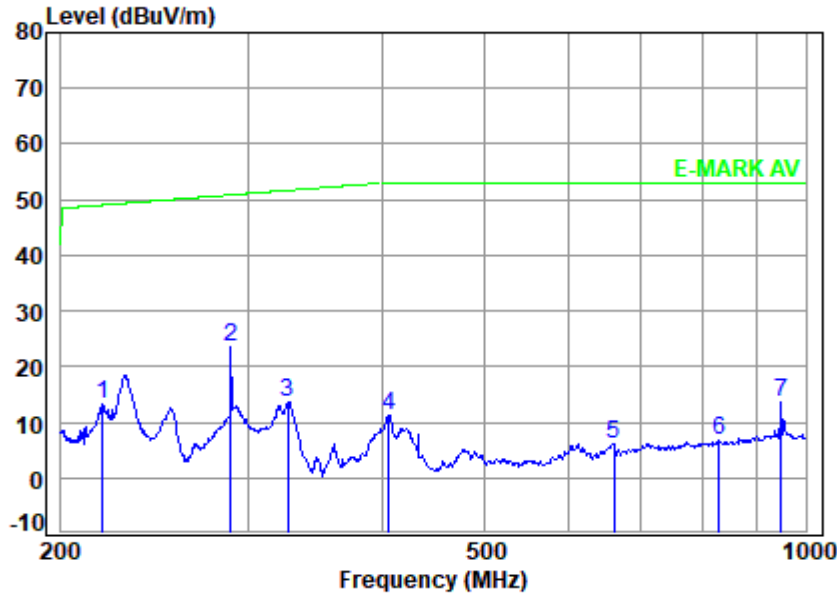

Condition: 1m Vertical

Job No : 05638AU

mode : 00

	Freq	Cable Loss	Ant Factor	Preamp Factor	Read Level	Level	Limit Line	Over Limit	Remark
	MHz	dB	dB/m	dB	dBuV	dBuV/m	dBuV/m	dB	
1	218.8630	1.24	13.00	32.58	31.55	13.21	49.04	-35.83	Average
2	288.6657	1.47	14.14	32.51	40.46	23.56	50.86	-27.30	Average
3	326.7502	1.58	14.60	32.47	30.07	13.78	51.67	-37.89	Average
4	406.0475	1.81	15.86	32.40	26.00	11.27	53.00	-41.73	Average
5	660.1851	2.41	18.03	32.34	18.02	6.12	53.00	-46.88	Average
6	828.3627	2.78	19.67	32.02	16.21	6.64	53.00	-46.36	Average
7	948.2743	3.02	20.68	31.15	20.90	13.45	53.00	-39.55	Average



Unless otherwise agreed in writing, this document is issued by the Company subject to its General Conditions of Service printed overleaf, available on request or accessible at <http://www.sgs.com/en/Terms-and-Conditions.aspx> and, for electronic format documents, subject to Terms and Conditions for Electronic Documents at <http://www.sgs.com/en/Terms-and-Conditions/Terms-e-Documents.aspx>. Attention is drawn to the limitation of liability, indemnification and jurisdiction issues defined therein. Any holder of this document is advised that information contained hereon reflects the Company's findings at the time of its intervention only and within the limits of Client's instructions, if any. The Company's sole responsibility is to its Client and this document does not exonerate parties to a transaction from exercising all their rights and obligations under the transaction documents. This document cannot be reproduced except in full, without prior written approval of the Company. Any unauthorized alteration, forgery or falsification of the content or appearance of this document is unlawful and offenders may be prosecuted to the fullest extent of the law. Unless otherwise stated the results shown in this test report refer only to the sample(s) tested and such sample(s) are retained for 30 days only. Attention: To check the authenticity of testing /inspection report & certificate, please contact us at telephone: (86-755) 8307 1443, or email: [CN.Doccheck@sgs.com](mailto:CN.Doccheck@sgs.com)

SGS-CSTC Standards Technical Services Co., Ltd.  
Shenzhen Branch Testing & Calibration Laboratory

Room 105, Building A, Xixiang Technology Industrial Park, No. 30 Fengtang Road, Xixiang Community, Fuyong Street, Bao'an District, Shenzhen, China 518103 t (86-755) 26012053 f (86-755) 26710594 www.sgs.com.cn  
中国·深圳·宝安区福永街道新田社区凤塘大道30号鑫龙科技工业园A栋105室 邮编: 518103 t (86-755) 26012053 f (86-755) 26710594 sgs.china@sgs.com

**6.2 Conducted transient disturbances**

Test Requirement: ECE R10.06  
 Test Method: ISO 7637-2:2004

Limit:

Table – Limits of transient disturbances

Polarity of pulse amplitude	Maximum allowed pulse amplitude for	
	Vehicles 12V systems	Vehicles 24V systems
Positive	+75	+150
Negative	-100	-450

**6.2.1 E.U.T. Operation**

Operating Environment:  
 Temperature: 25.3 °C Humidity: 48.6 % RH Atmospheric Pressure: 1015 mbar

**6.2.2 Test Mode Description**

Pre-scan / Final test	Mode Code	Description
Final test	00	DC 13.5V Power Supply_Keep EUT working normally.
Final test	01	DC 27V Power Supply_Keep EUT working normally.



Unless otherwise agreed in writing, this document is issued by the Company subject to its General Conditions of Service printed overleaf, available on request or accessible at <http://www.sgs.com/en/Terms-and-Conditions.aspx> and, for electronic format documents, subject to Terms and Conditions for Electronic Documents at <http://www.sgs.com/en/Terms-and-Conditions/Terms-e-Documents.aspx>. Attention is drawn to the limitation of liability, indemnification and jurisdiction issues defined therein. Any holder of this document is advised that information contained hereon reflects the Company's findings at the time of its intervention only and within the limits of Client's instructions, if any. The Company's sole responsibility is to its Client and this document does not exonerate parties to a transaction from exercising all their rights and obligations under the transaction documents. This document cannot be reproduced except in full, without prior written approval of the Company. Any unauthorized alteration, forgery or falsification of the content or appearance of this document is unlawful and offenders may be prosecuted to the fullest extent of the law. Unless otherwise stated the results shown in this test report refer only to the sample(s) tested and such sample(s) are retained for 30 days only.  
**Attention: To check the authenticity of testing /inspection report & certificate, please contact us at telephone: (86-755) 8307 1443, or email: CN.Doccheck@sgs.com**  
 Room 105, Building A, Xixiang Technology Industrial Park, No. 30 Fengtang Road, Xixiang Community, Fuyong Street, Bao'an District, Shenzhen, China 518103 t (86-755) 26012053 f (86-755) 26710594 www.sgs.com.cn  
 中国·深圳·宝安区福永街道新田社区凤塘大道50号鑫龙科技工业园A栋105室 邮编: 518103 t (86-755) 26012053 f (86-755) 26710594 sgs.china@sgs.com

### 6.2.3 Test Setup Diagram

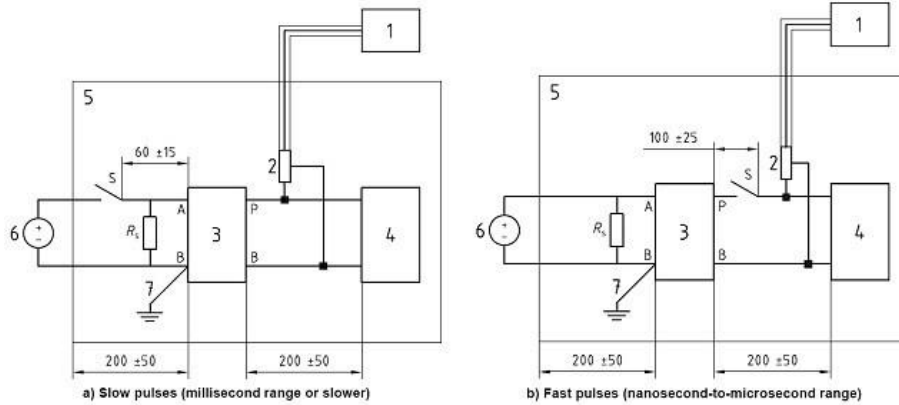

Key	
1. oscilloscope	5. ground plane
2. voltage probe	6. power supply
3. artificial network	7. Ground connection; length 100 mm
4. EUT(source of transient)	

### 6.2.4 Measurement Procedure and Data

For 12V system

Limit	Measured Value [V]			
	Slow pulse OFF→ON	Slow pulse ON→OFF	Fast pulse OFF→ON	Fast pulse ON→OFF
+75V	+0.9V	+0.5V	+0.9V	+0.5V
-100V	-13.9V	-14.3V	-13.9V	-14.3V

For 24V system

Limit	Measured Value [V]			
	Slow pulse OFF→ON	Slow pulse ON→OFF	Fast pulse OFF→ON	Fast pulse ON→OFF
+150V	+8.2V	+1.4V	+8.6V	+1V
-450V	-28.2V	-28.6V	-28.2V	-28.6V



Unless otherwise agreed in writing, this document is issued by the Company subject to its General Conditions of Service printed overleaf, available on request or accessible at <http://www.sgs.com/en/Terms-and-Conditions.aspx> and, for electronic format documents, subject to Terms and Conditions for Electronic Documents at <http://www.sgs.com/en/Terms-and-Conditions/Terms-e-Documents.aspx>. Attention is drawn to the limitation of liability, indemnification and jurisdiction issues defined therein. Any holder of this document is advised that information contained hereon reflects the Company's findings at the time of its intervention only and within the limits of Client's instructions, if any. The Company's sole responsibility is to its Client and this document does not exonerate parties to a transaction from exercising all their rights and obligations under the transaction documents. This document cannot be reproduced except in full, without prior written approval of the Company. Any unauthorized alteration, forgery or falsification of the content or appearance of this document is unlawful and offenders may be prosecuted to the fullest extent of the law. Unless otherwise stated the results shown in this test report refer only to the sample(s) tested and such sample(s) are retained for 30 days only.

Attention: To check the authenticity of testing /inspection report & certificate, please contact us at telephone: (86-755) 8307 1443, or email: [CN.Doccheck@sgs.com](mailto:CN.Doccheck@sgs.com)

SGS-CSTC Standards Technical Services Co., Ltd.  
Shenzhen Branch Testing & Calibration Laboratory

Room 105, Building A, Xixiang Technology Industrial Park, No. 30 Fenggang Road, Xixiang Community, Fuyong Street, Bao'an District, Shenzhen, China 518103 t (86-755) 26012053 f (86-755) 26710594 www.sgsgroup.com.cn  
中国·深圳·宝安区福永街道新田社区凤塘大道50号鑫龙科技园A栋105室 邮编: 518103 t (86-755) 26012053 f (86-755) 26710594 sgs.china@sgs.com

Mode 00					
Switch type	Pulse	Test Times	Off → On		
			Fast Pulses		
			Worst Reading	Limit	Result
Electronic switch	Positive	10	+0.9V	+75V	Pass
	Negative		-13.9V	-100V	Pass

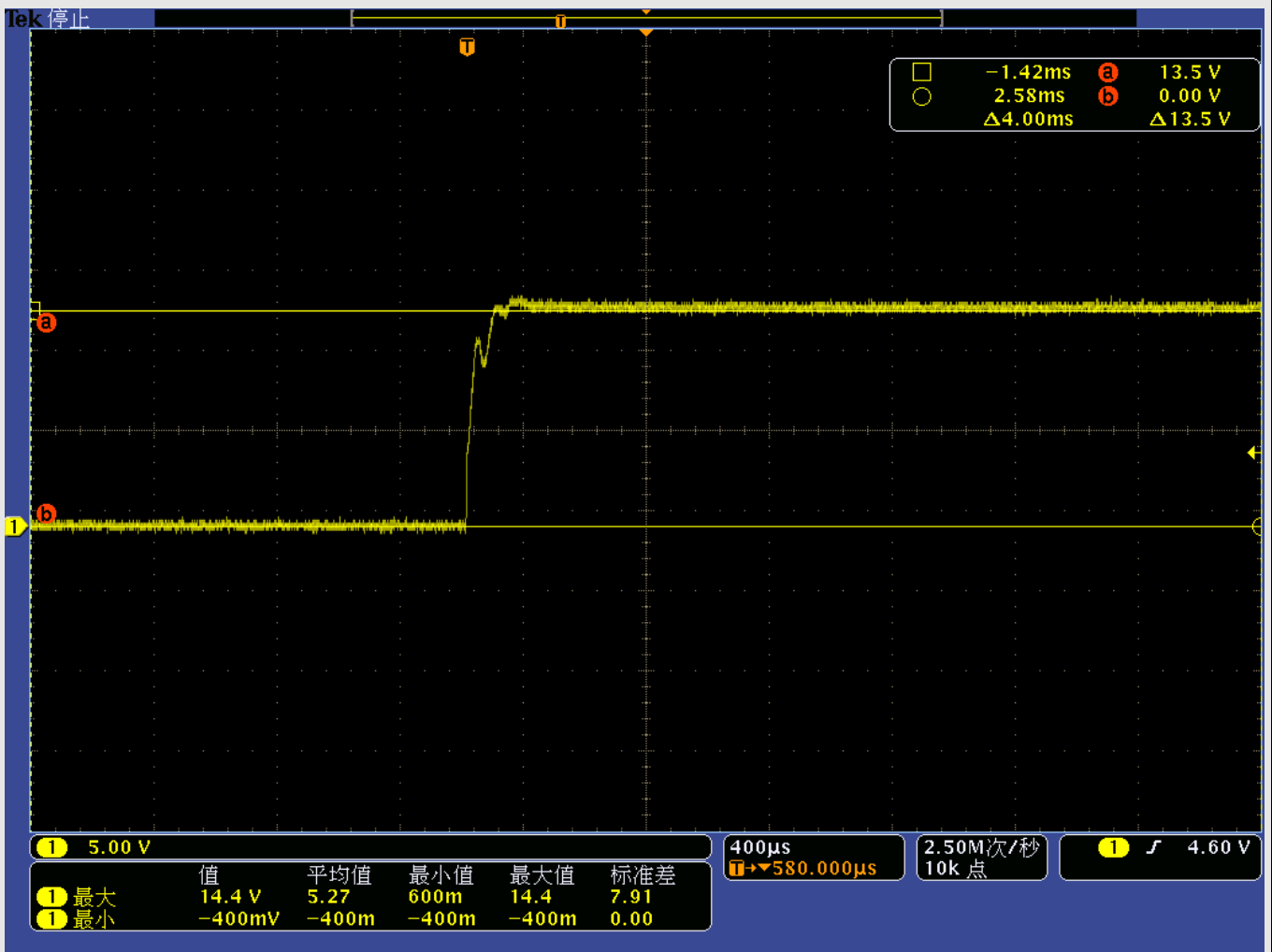

maximum amplitude



Mode 00					
Switch type	Pulse	Test Times	On → Off		
			Fast Pulses		
			Worst Reading	Limit	Result
Electronic switch	Positive	10	+0.5V	+75V	Pass
	Negative		-14.3V	-100V	Pass

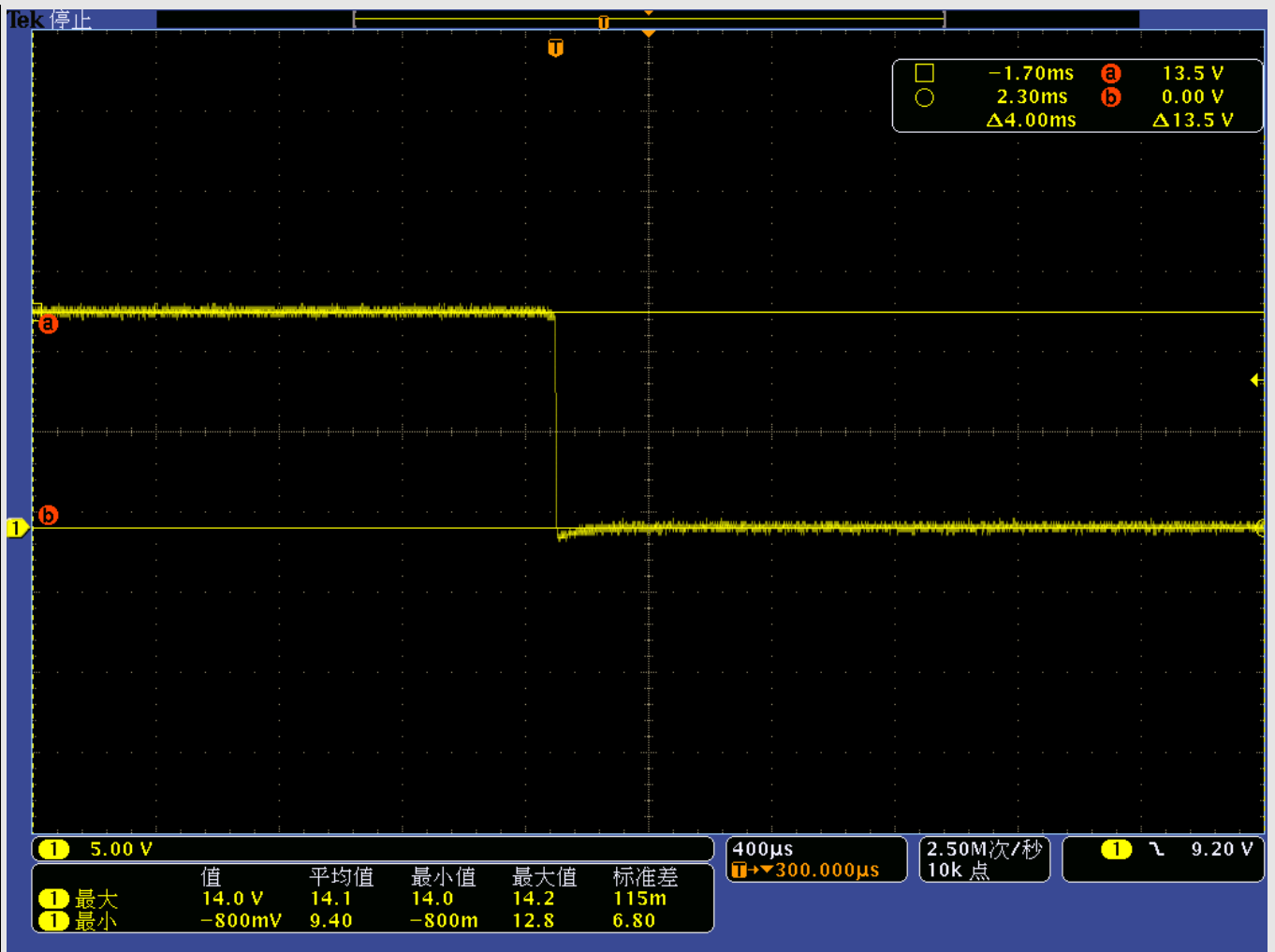

maximum amplitude



Mode 00					
Switch type	Pulse	Test Times	Off → On		
			Slow Pulses		
			Worst Reading	Limit	Result
Electronic switch	Positive	10	+0.9V	+75V	Pass
	Negative		-13.9V	-100V	Pass

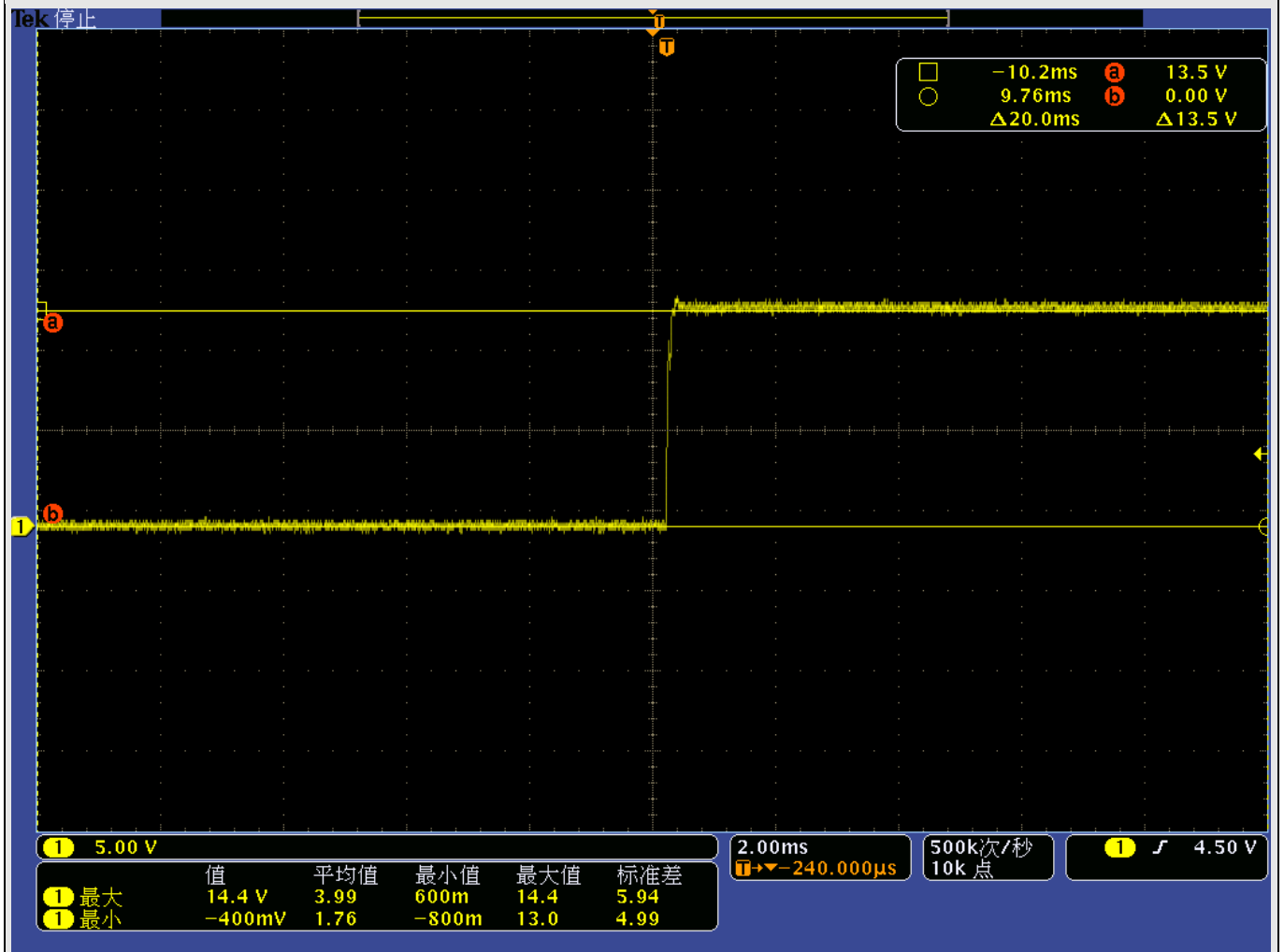

maximum amplitude



Mode 00					
Switch type	Pulse	Test Times	On → Off		
			Slow Pulses		
			Worst Reading	Limit	Result
Electronic switch	Positive	10	+0.5V	+75V	Pass
	Negative		-14.3V	-100V	Pass

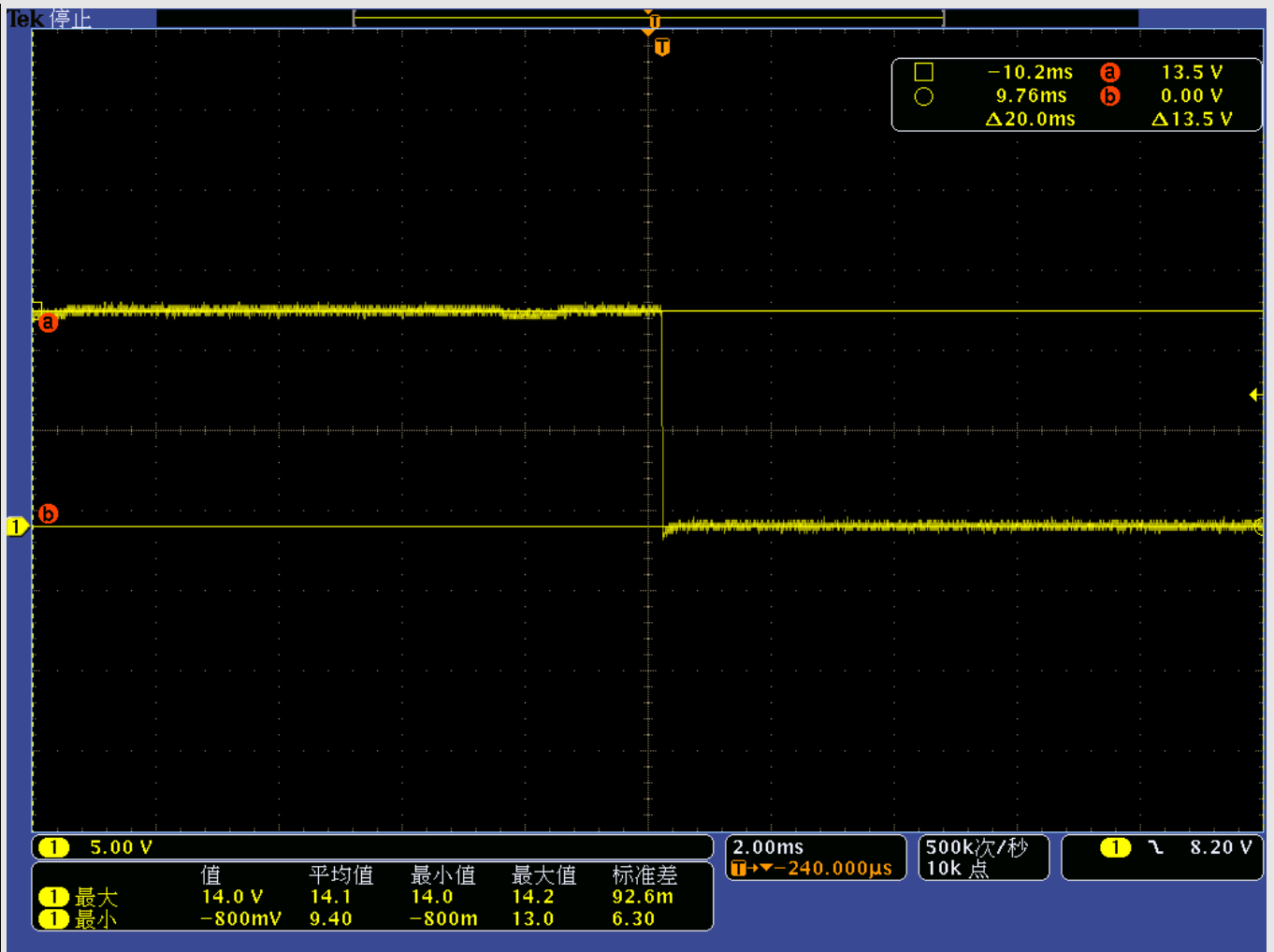

maximum amplitude



Mode 01					
Switch type	Pulse	Test Times	off → on		
			Fast Pulses		
			Worst Reading	Limit	Result
Electronic switch	Positive	10	+8.6V	+150V	Pass
	Negative		-28.2V	-450V	Pass

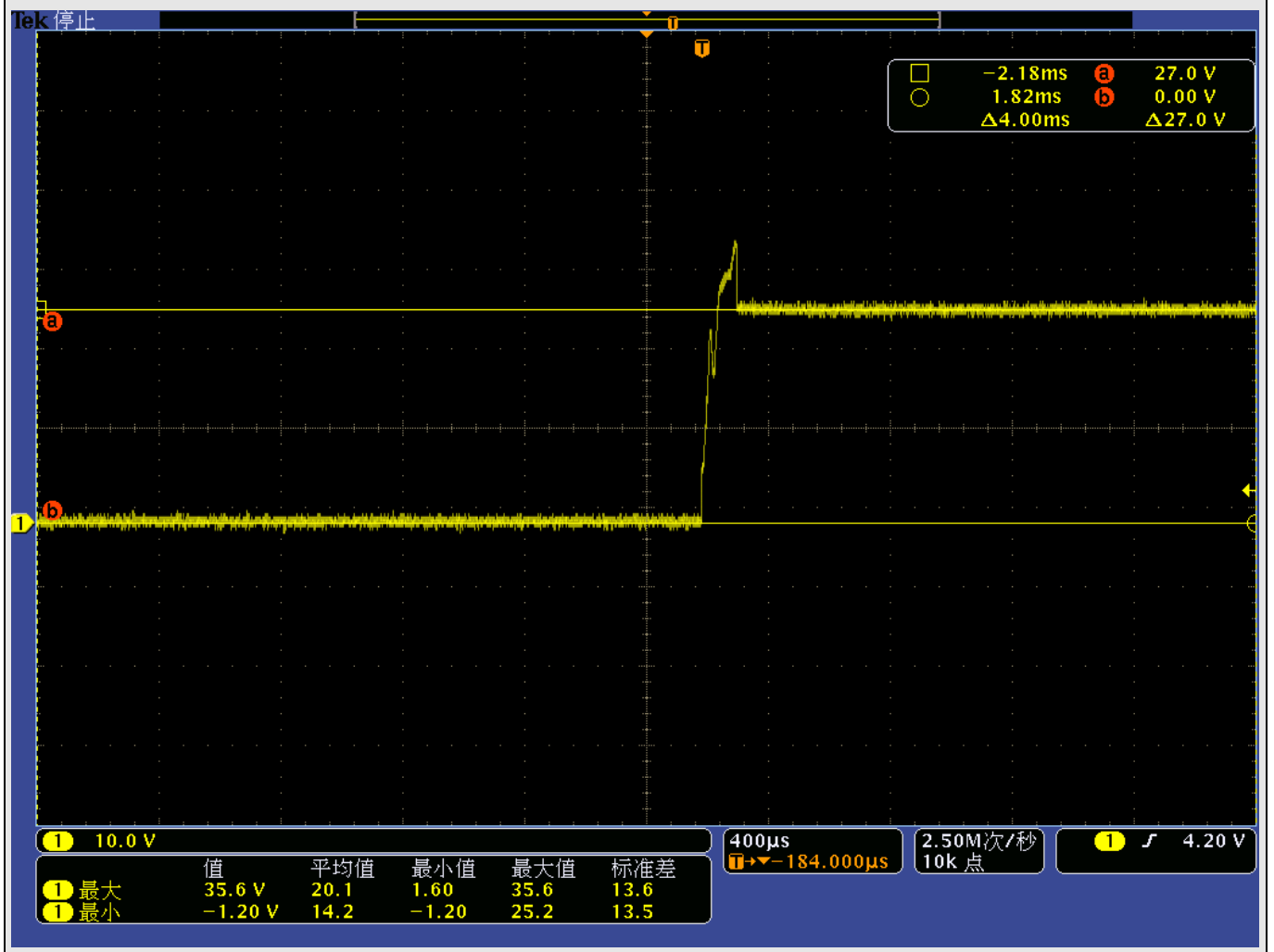

maximum amplitude



Mode 01					
Switch type	Pulse	Test Times	on→off		
			Fast Pulses		
			Worst Reading	Limit	Result
Electronic switch	Positive	10	+1V	+150V	Pass
	Negative		-28.6V	-450V	Pass

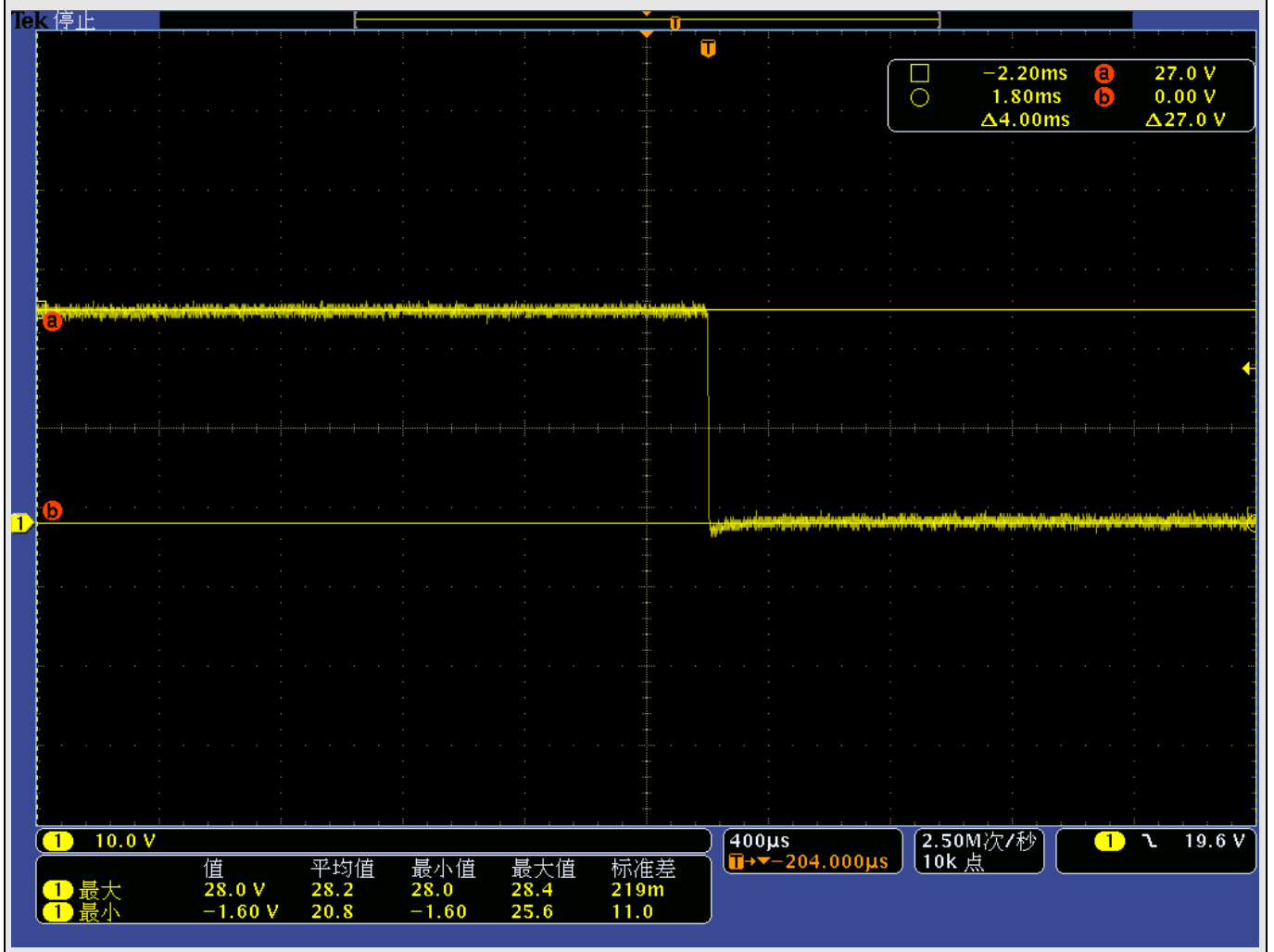

maximum amplitude



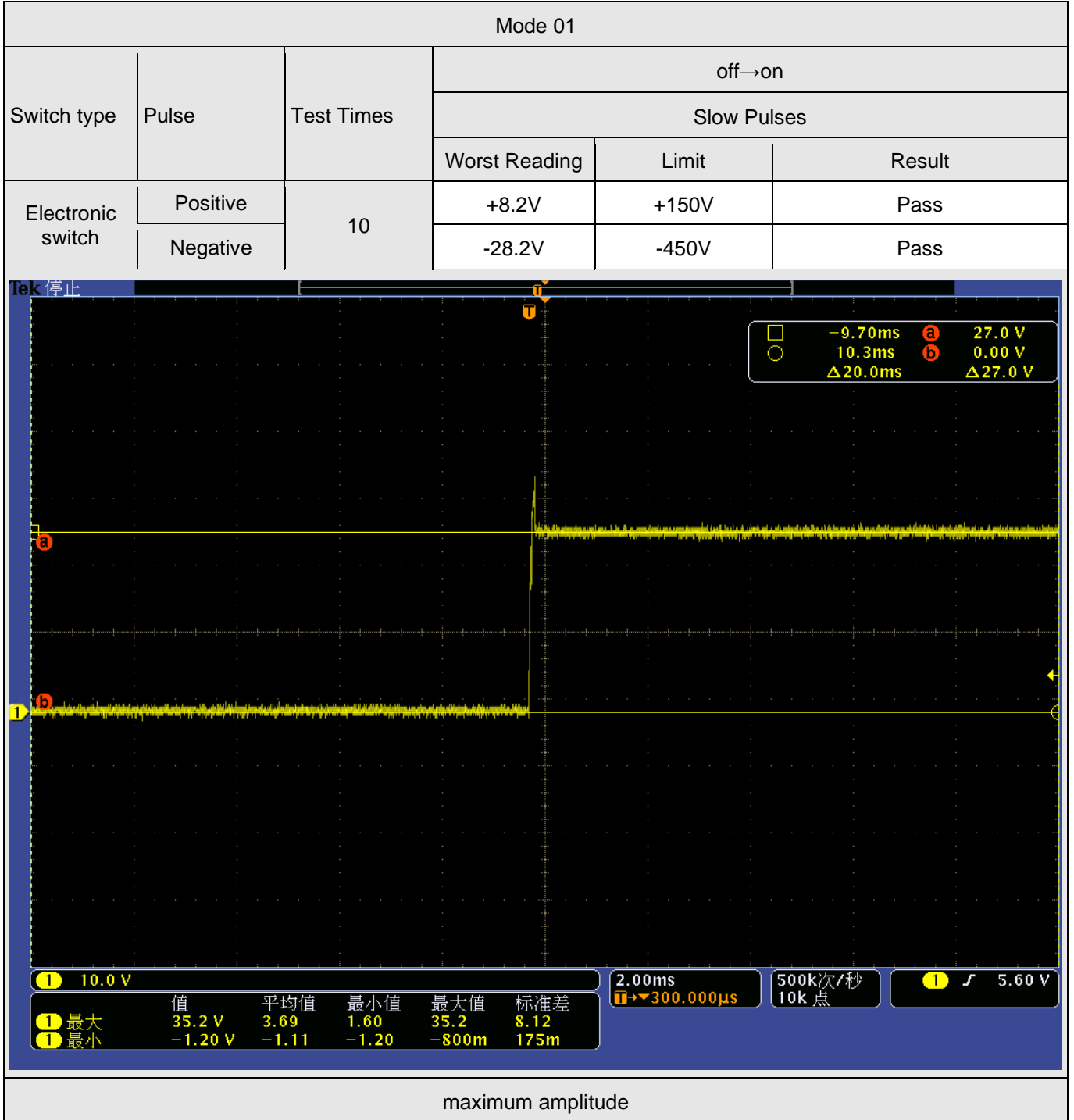

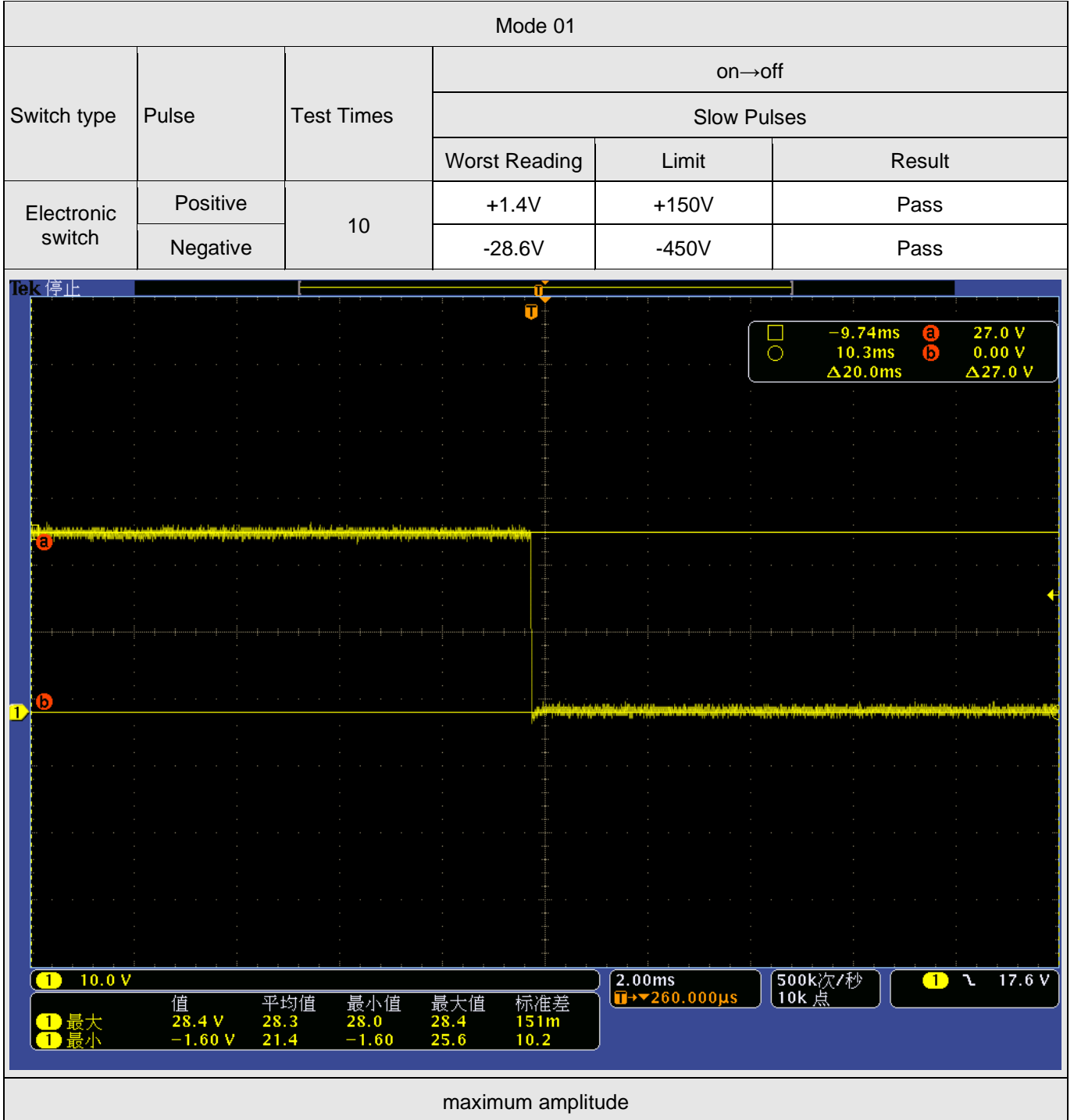

### 7 Immunity Test Results

**Performance Criteria Description in ECE R10-06, ISO 7637-2:2004, ISO 11452-2:2004 and ISO 11452-4:2011.**

- Criterion A** All functions of a device/system perform as designed during and after exposure to disturbance
- Criterion B** All functions of a device/system perform as designed during exposure. However, one or more of them can go beyond specified tolerance. All functions return automatically to within normal limits after exposure is removed. Memory functions shall remain class A
- Criterion C** One or more functions of a device/system do not perform as designed during exposure but return automatically to normal operation after exposure is removed
- Criterion D** One or more functions of a device/system do not perform as designed during exposure and do not return to normal operation until exposure is removed and the device/system is reset by simple "operator/use" action
- Criterion E** One or more functions of a device/system do not perform as designed during and after exposure and cannot be returned to proper operation without repairing or replacing the device/system



Unless otherwise agreed in writing, this document is issued by the Company subject to its General Conditions of Service printed overleaf, available on request or accessible at <http://www.sgs.com/en/Terms-and-Conditions.aspx> and, for electronic format documents, subject to Terms and Conditions for Electronic Documents at <http://www.sgs.com/en/Terms-and-Conditions/Terms-e-Documents.aspx>. Attention is drawn to the limitation of liability, indemnification and jurisdiction issues defined therein. Any holder of this document is advised that information contained hereon reflects the Company's findings at the time of its intervention only and within the limits of Client's instructions, if any. The Company's sole responsibility is to its Client and this document does not exonerate parties to a transaction from exercising all their rights and obligations under the transaction documents. This document cannot be reproduced except in full, without prior written approval of the Company. Any unauthorized alteration, forgery or falsification of the content or appearance of this document is unlawful and offenders may be prosecuted to the fullest extent of the law. Unless otherwise stated the results shown in this test report refer only to the sample(s) tested and such sample(s) are retained for 30 days only.  
**Attention: To check the authenticity of testing /inspection report & certificate, please contact us at telephone: (86-755) 8307 1443, or email: CN.Doccheck@sgs.com**

Room 105, Building A, Xixiang Technology Industrial Park, No. 30 Fengtang Road, Xixiang Community, Fuyong Street, Bao'an District, Shenzhen, China 518103 t (86-755) 26012053 f (86-755) 26710594 www.sgs.com.cn  
中国·深圳·宝安区福永街道新田社区凤塘大道50号鑫龙科技园A栋105室 邮编: 518103 t (86-755) 26012053 f (86-755) 26710594 sgs.china@sgs.com

### 7.1 Conducted transient immunity

Test Requirement: ECE R10.06  
 Test Method: ISO 7637-2:2004  
 Test Voltage: DC 13.5V & DC 27V  
 Limit: Table 4 of EN50498

#### 7.1.1 Test Setup Diagram

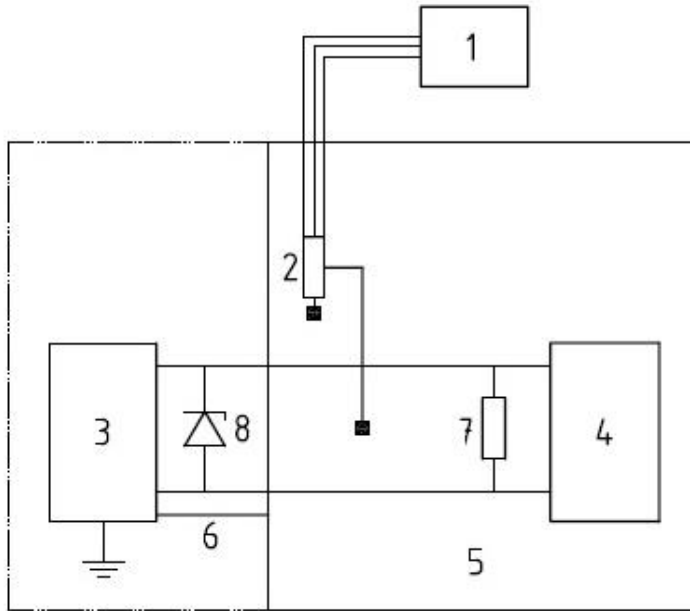

#### Key

- |   |   |   |  |
|---|---|---|--|
| 1 | oscilloscope or equivalent                      | 5 | ground plane                             |
| 2 | voltage probe                                   | 6 | Ground connection                        |
| 3 | test pulse generator with internal power supply | 7 | optional resistor ( $R_v$ ) <sup>a</sup> |
|   | resistance $R_i$                                | 8 | optional diode bridge <sup>b</sup>       |
| 4 | DUT   |   |  |

#### 7.1.2 E.U.T. Operation

Operating Environment:

Temperature: 25.6 °C      Humidity: 48.2 % RH      Atmospheric Pressure: 1015 mbar



Unless otherwise agreed in writing, this document is issued by the Company subject to its General Conditions of Service printed overleaf, available on request or accessible at <http://www.sgs.com/en/Terms-and-Conditions.aspx> and, for electronic format documents, subject to Terms and Conditions for Electronic Documents at <http://www.sgs.com/en/Terms-and-Conditions/Terms-e-Documents.aspx>. Attention is drawn to the limitation of liability, indemnification and jurisdiction issues defined therein. Any holder of this document is advised that information contained hereon reflects the Company's findings at the time of its intervention only and within the limits of Client's instructions, if any. The Company's sole responsibility is to its Client and this document does not exonerate parties to a transaction from exercising all their rights and obligations under the transaction documents. This document cannot be reproduced except in full, without prior written approval of the Company. Any unauthorized alteration, forgery or falsification of the content or appearance of this document is unlawful and offenders may be prosecuted to the fullest extent of the law. Unless otherwise stated the results shown in this test report refer only to the sample(s) tested and such sample(s) are retained for 30 days only.  
**Attention: To check the authenticity of testing /inspection report & certificate, please contact us at telephone: (86-755) 8307 1443, or email: CN.Doccheck@sgs.com**

SGS-CSTC Standards Technical Services Co., Ltd.  
 Shenzhen Branch Testing & Calibration Laboratory

Room 105, Building A, Xixiang Technology Industrial Park, No. 50 Fengtang Road, Xixiang Community, Fuyong Street, Bao'an District, Shenzhen, China 518103 t (86-755) 26012053 f (86-755) 26710594 www.sgs.com.cn  
 中国·深圳·宝安区福永街道新田社区凤塘大道50号鑫龙科技园A栋105室 邮编: 518103 t (86-755) 26012053 f (86-755) 26710594 sgs.china@sgs.com

**7.1.3 Test Mode Description**

Pre-scan / Final test	Mode Code	Description
Final test	00	DC 13.5V Power Supply_Keep EUT working normally.
Final test	01	DC 27V Power Supply_Keep EUT working normally.

**7.1.4 Test Condition and Results:**

Test Pulse Number	Immunity Test Level	Min. number of pulses or test time	Performance Criterion required	Result / Observations
1	III (Us=-75V)	5000 pulses	C	C
2a	III (Us=+37V)	5000 pulses	B	A
2b	III (Us=+10V)	10 pulses	C	C
3a	III (Us=-112V)	1h	A	A
3b	III (Us=+75V)	1h	A	A
4	III (Us=-6V)	1 pulse	C	A
1	III (Us=-450V)	5000 pulses	C	C
2a	III (Us=+37V)	5000 pulses	B	A
2b	III (Us=+20V)	10 pulses	C	C
3a	III (Us=-150V)	1h	A	A
3b	III (Us=+150V)	1h	A	A
4	III (Us=-12V)	1 pulse	C	A

A: No degradation in the performance of the EUT was observed

C: The EUT resets periodically during the test and manual recovery after the test (comply with DUT logic setting requirements)



Unless otherwise agreed in writing, this document is issued by the Company subject to its General Conditions of Service printed overleaf, available on request or accessible at <http://www.sgs.com/en/Terms-and-Conditions.aspx> and, for electronic format documents, subject to Terms and Conditions for Electronic Documents at <http://www.sgs.com/en/Terms-and-Conditions/Terms-e-Documents.aspx>. Attention is drawn to the limitation of liability, indemnification and jurisdiction issues defined therein. Any holder of this document is advised that information contained hereon reflects the Company's findings at the time of its intervention only and within the limits of Client's instructions, if any. The Company's sole responsibility is to its Client and this document does not exonerate parties to a transaction from exercising all their rights and obligations under the transaction documents. This document cannot be reproduced except in full, without prior written approval of the Company. Any unauthorized alteration, forgery or falsification of the content or appearance of this document is unlawful and offenders may be prosecuted to the fullest extent of the law. Unless otherwise stated the results shown in this test report refer only to the sample(s) tested and such sample(s) are retained for 30 days only.  
**Attention: To check the authenticity of testing /inspection report & certificate, please contact us at telephone: (86-755) 8307 1443, or email: CN.Doccheck@sgs.com**  
 Room 105, Building A, Xixiang Technology Industrial Park, No. 30 Fengtang Road, Xixiang Community, Fuyong Street, Bao'an District, Shenzhen, China 518103 t (86-755) 26012053 f (86-755) 26710594 www.sgsgroup.com.cn  
 中国·深圳·宝安区福永街道新田社区凤塘大道30号鑫龙科技工业园A栋105室 邮编: 518103 t (86-755) 26012053 f (86-755) 26710594 sgs.china@sgs.com

### 7.2 Bulk Current Injection(20MHz-400MHz)

Test Requirement: ECE R10.06  
 Test Method: ISO 11452-4:2011

#### 7.2.1 Test Setup Diagram

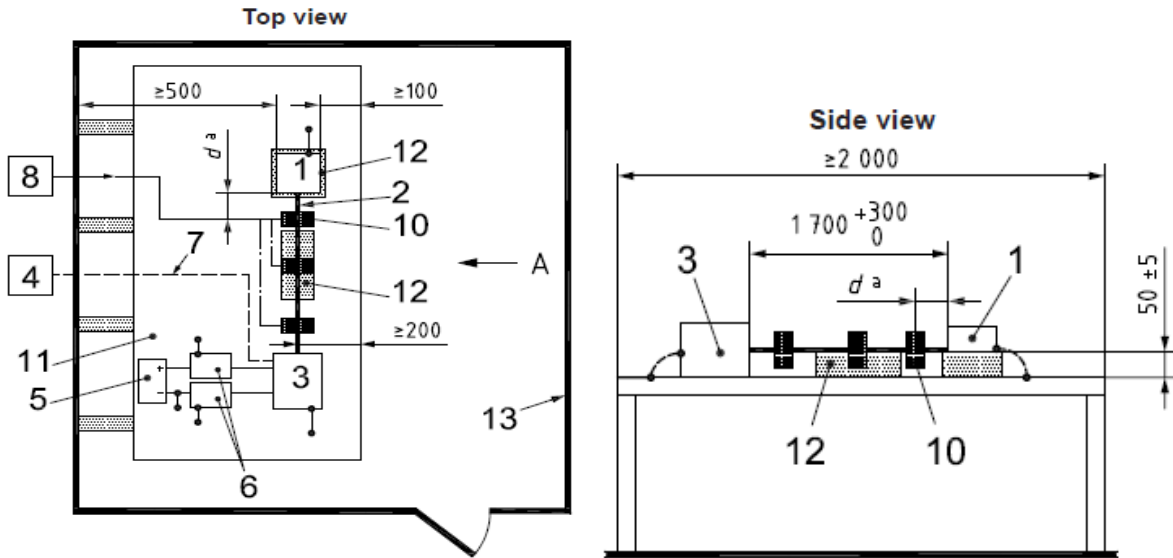

**Key**

- 1 DUT (connected to ground if specified in the test plan)
- 2 wiring harness (S)
- 3 load simulator (placement and ground connection according to 7.5)
- 4 stimulation and monitoring system
- 5 power supply
- 6 AN
- 7 optical fibres
- 8 high-frequency equipment
- 9 optional current measurement probe (not shown in this figure, but shown in Figure 2)
- 10 injection probe (represented at 3 positions)
- 11 ground plane (connected to the shielded room)
- 12 low relative permittivity support ( $\epsilon_r \leq 1.4$ )
- 13 shielded room

Figure — Bulk Current Injection configuration — Substitution method

#### 7.2.2 E.U.T. Operation

Operating Environment:

Temperature: 22.6 °C      Humidity: 52.0 % RH      Atmospheric Pressure: 1015 mbar

#### 7.2.3 Test Mode Description

Pre-scan / Final test	Mode Code	Description
Final test	00	DC 13.5V Power Supply_Keep EUT working normally.
Final test	01	DC 27V Power Supply_Keep EUT working normally.



Unless otherwise agreed in writing, this document is issued by the Company subject to its General Conditions of Service printed overleaf, available on request or accessible at <http://www.sgs.com/en/Terms-and-Conditions.aspx> and, for electronic format documents, subject to Terms and Conditions for Electronic Documents at <http://www.sgs.com/en/Terms-and-Conditions/Terms-e-Documents.aspx>. Attention is drawn to the limitation of liability, indemnification and jurisdiction issues defined therein. Any holder of this document is advised that information contained hereon reflects the Company's findings at the time of its intervention only and within the limits of Client's instructions, if any. The Company's sole responsibility is to its Client and this document does not exonerate parties to a transaction from exercising all their rights and obligations under the transaction documents. This document cannot be reproduced except in full, without prior written approval of the Company. Any unauthorized alteration, forgery or falsification of the content or appearance of this document is unlawful and offenders may be prosecuted to the fullest extent of the law. Unless otherwise stated the results shown in this test report refer only to the sample(s) tested and such sample(s) are retained for 30 days only.  
 Attention: To check the authenticity of testing /inspection report & certificate, please contact us at telephone: (86-755) 8307 1443, or email: CN.Doccheck@sgs.com  
 Room 105, Building A, Xixiang Technology Industrial Park, No. 50 Fengqiang Road, Xixiang Community, Fuyong Street, Bao'an District, Shenzhen, China 518103 t (86-755) 26012053 f (86-755) 26710594 www.sgs.com.cn  
 中国·深圳·宝安区福永街道新田社区凤塘大道50号鑫龙科技工业园A栋105室 邮编: 518103 t (86-755) 26012053 f (86-755) 26710594 sgs.china@sgs.com

**7.2.4 Test Condition and Results:**

Frequency (MHz)	Test Level (mA)	Test Location	Step Size	Dwell Time	Result / Observations
20~400	60	15cm	5%	2s	A
A: No degradation in the performance of the EUT was observed					



Unless otherwise agreed in writing, this document is issued by the Company subject to its General Conditions of Service printed overleaf, available on request or accessible at <http://www.sgs.com/en/Terms-and-Conditions.aspx> and, for electronic format documents, subject to Terms and Conditions for Electronic Documents at <http://www.sgs.com/en/Terms-and-Conditions/Terms-e-Documents.aspx>. Attention is drawn to the limitation of liability, indemnification and jurisdiction issues defined therein. Any holder of this document is advised that information contained hereon reflects the Company's findings at the time of its intervention only and within the limits of Client's instructions, if any. The Company's sole responsibility is to its Client and this document does not exonerate parties to a transaction from exercising all their rights and obligations under the transaction documents. This document cannot be reproduced except in full, without prior written approval of the Company. Any unauthorized alteration, forgery or falsification of the content or appearance of this document is unlawful and offenders may be prosecuted to the fullest extent of the law. Unless otherwise stated the results shown in this test report refer only to the sample(s) tested and such sample(s) are retained for 30 days only.

**Attention: To check the authenticity of testing /inspection report & certificate, please contact us at telephone: (86-755) 8307 1443, or email: CN.Doccheck@sgs.com**

Room 105, Building A, Xixiang Technology Industrial Park, No. 30 Fengtang Road, Xixiang Community, Fuyong Street, Bao'an District, Shenzhen, China 518103 t (86-755) 26012053 f (86-755) 26710594 www.sgs.com.cn  
 中国·深圳·宝安区福永街道新田社区凤塘大道30号鑫龙科技工业园A栋105室 邮编: 518103 t (86-755) 26012053 f (86-755) 26710594 sgs.china@sgs.com

### 7.3 Radiation immunity-ALSE(400MHz-2GHz)

Test Requirement: ECE R10.06  
 Test Method: ISO 11452-2:2004

#### 7.3.1 Test Setup Diagram

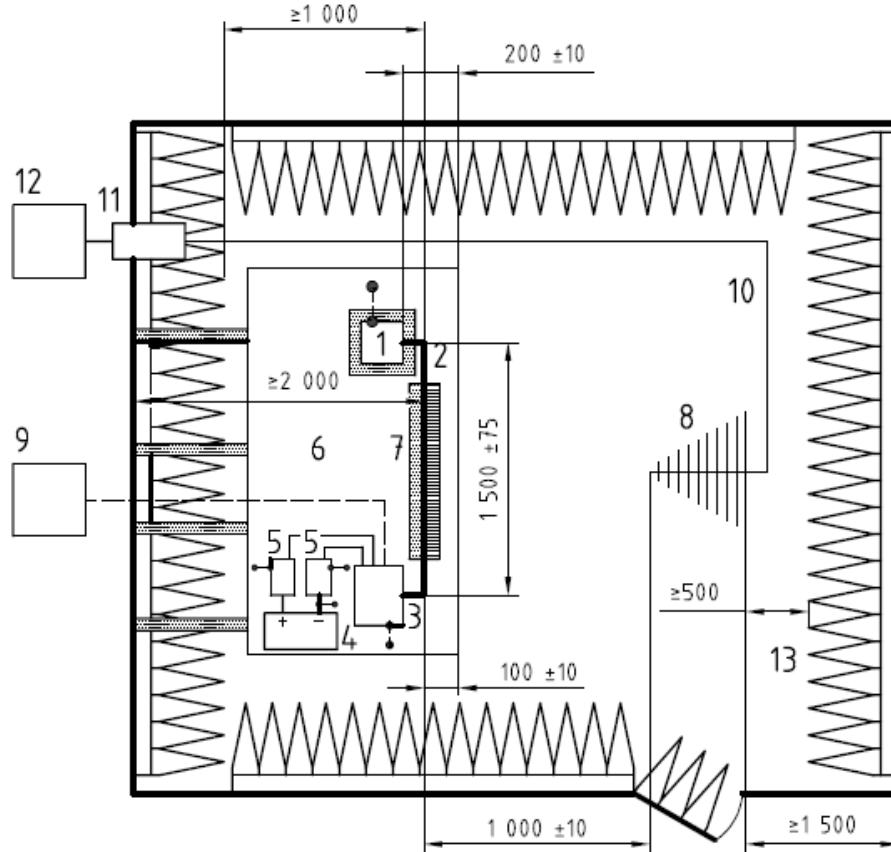

#### Key

- |  |   |  |
|--|---|--|
| 1 DUT (grounded locally if required in test plan)                    | 6 ground plane (bonded to shielded enclosure)                 | 10 high quality double-shielded coaxial cable (50 Ω) |
| 2 test harness   | 7 low relative permittivity support ( $\epsilon_r \leq 1.4$ ) | 11 bulkhead connector                                |
| 3 load simulator (placement and ground: connection according to 7.5) | 8 log-periodic antenna  | 12 RF signal generator and amplifier                 |
| 4 power supply (location optional)                                   | 9 stimulation and monitoring system                           | 13 RF absorber material                              |
| 5 artificial network (AN)  |   |  |

Figure — Example test set-up — Log-periodic antenna





**7.3.3 Test Mode Description**

Pre-scan / Final test	Mode Code	Description
Final test	00	DC 13.5V Power Supply_Keep EUT working normally.
Final test	01	DC 27V Power Supply_Keep EUT working normally.

**7.3.4 Test Condition and Results:**

Frequency (MHz)	Test Level (V/m)	EUT Face	Step Size	Dwell time	Result / Observations
400~800	30	Front	2%	2s	A
800~2000	30	Front	2%	2s	A

A: No degradation in the performance of the EUT was observed



Unless otherwise agreed in writing, this document is issued by the Company subject to its General Conditions of Service printed overleaf, available on request or accessible at <http://www.sgs.com/en/Terms-and-Conditions.aspx> and, for electronic format documents, subject to Terms and Conditions for Electronic Documents at <http://www.sgs.com/en/Terms-and-Conditions/Terms-e-Documents.aspx>. Attention is drawn to the limitation of liability, indemnification and jurisdiction issues defined therein. Any holder of this document is advised that information contained hereon reflects the Company's findings at the time of its intervention only and within the limits of Client's instructions, if any. The Company's sole responsibility is to its Client and this document does not exonerate parties to a transaction from exercising all their rights and obligations under the transaction documents. This document cannot be reproduced except in full, without prior written approval of the Company. Any unauthorized alteration, forgery or falsification of the content or appearance of this document is unlawful and offenders may be prosecuted to the fullest extent of the law. Unless otherwise stated the results shown in this test report refer only to the sample(s) tested and such sample(s) are retained for 30 days only.  
**Attention: To check the authenticity of testing /inspection report & certificate, please contact us at telephone: (86-755) 8307 1443, or email: CN.Doccheck@sgs.com**

### 8 Test Setup Photo

#### Radiated Emission(30MHz-1GHz)

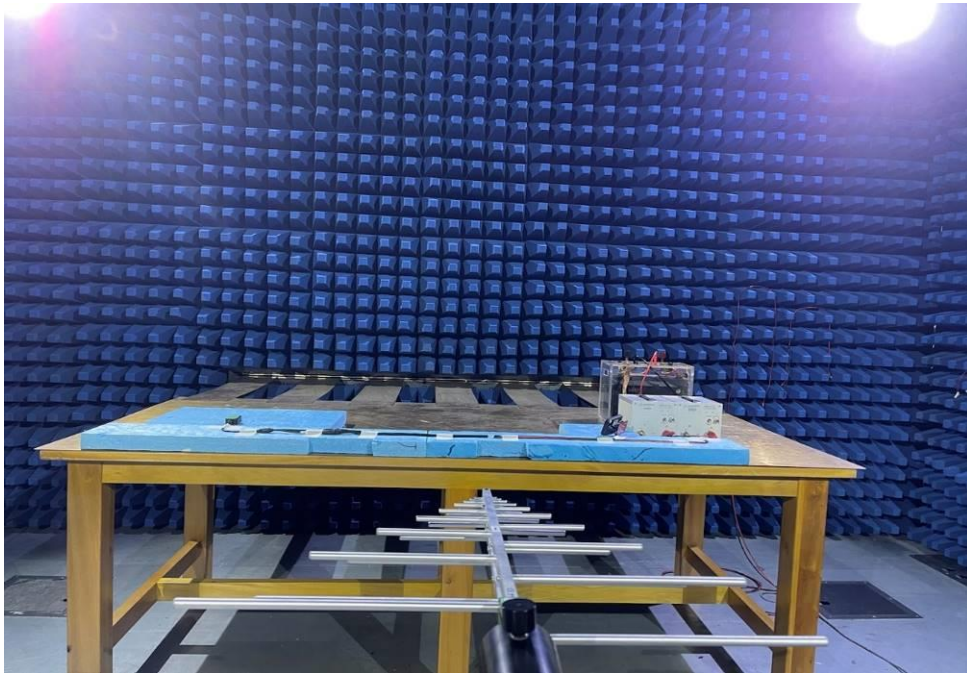
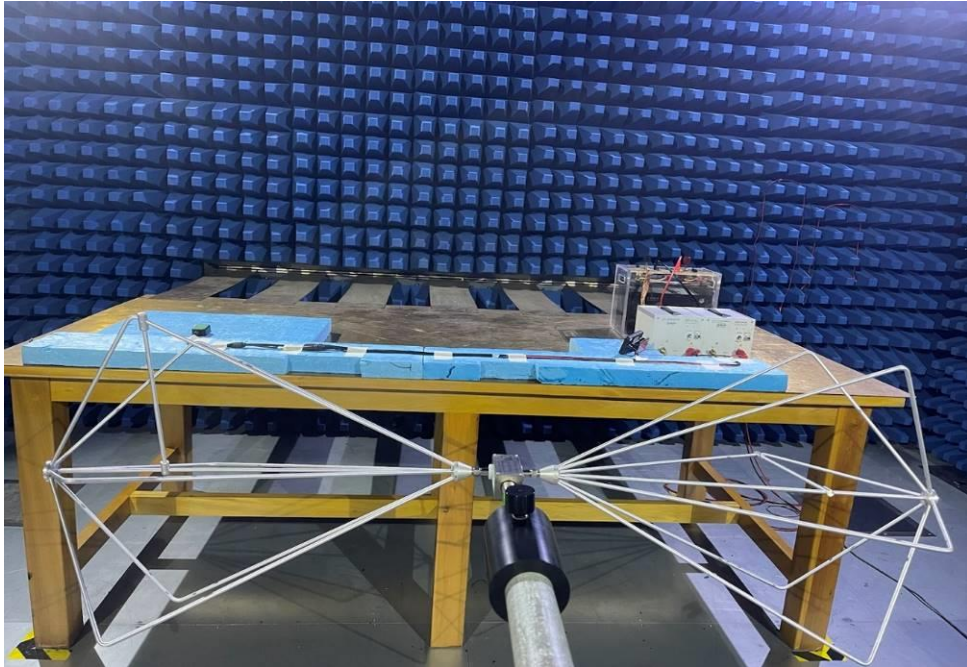

Unless otherwise agreed in writing, this document is issued by the Company subject to its General Conditions of Service printed overleaf, available on request or accessible at <http://www.sgs.com/en/Terms-and-Conditions.aspx> and, for electronic format documents, subject to Terms and Conditions for Electronic Documents at <http://www.sgs.com/en/Terms-and-Conditions/Terms-e-Documents.aspx>. Attention is drawn to the limitation of liability, indemnification and jurisdiction issues defined therein. Any holder of this document is advised that information contained hereon reflects the Company's findings at the time of its intervention only and within the limits of Client's instructions, if any. The Company's sole responsibility is to its Client and this document does not exonerate parties to a transaction from exercising all their rights and obligations under the transaction documents. This document cannot be reproduced except in full, without prior written approval of the Company. Any unauthorized alteration, forgery or falsification of the content or appearance of this document is unlawful and offenders may be prosecuted to the fullest extent of the law. Unless otherwise stated the results shown in this test report refer only to the sample(s) tested and such sample(s) are retained for 30 days only.

**Attention:** To check the authenticity of testing / inspection report & certificate, please contact us at telephone: (86-755) 8307 1443, or email: [CN.Doccheck@sgs.com](mailto:CN.Doccheck@sgs.com)

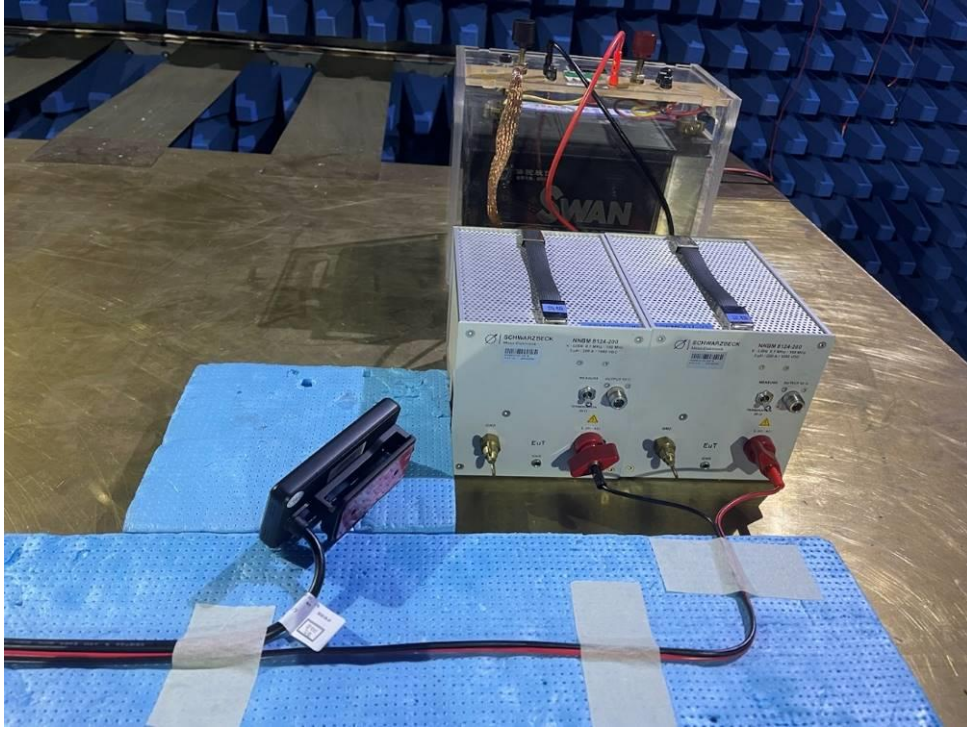

### Conducted transient disturbances

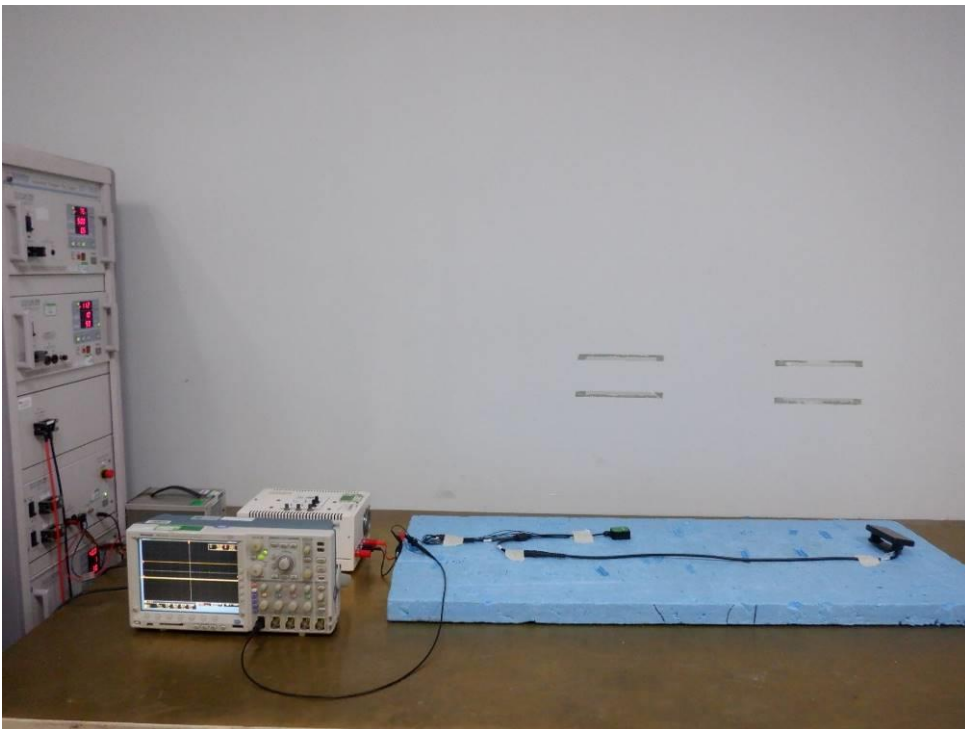
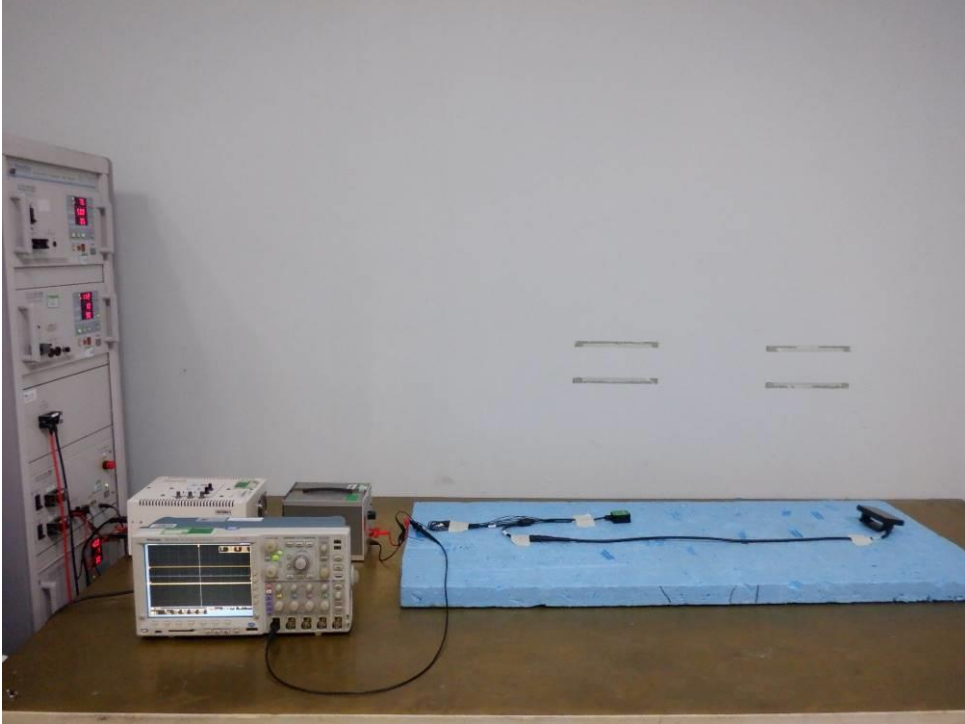

SGS-CSTC Standards Technical Services Co., Ltd.  
Shenzhen Branch Testing Center ETC Laboratory

Unless otherwise agreed in writing, this document is issued by the Company subject to its General Conditions of Service printed overleaf, available on request or accessible at <http://www.sgs.com/en/Terms-and-Conditions.aspx> and, for electronic format documents, subject to Terms and Conditions for Electronic Documents at <http://www.sgs.com/en/Terms-and-Conditions/Terms-e-Documents.aspx>. Attention is drawn to the limitation of liability, indemnification and jurisdiction issues defined therein. Any holder of this document is advised that information contained hereon reflects the Company's findings at the time of its intervention only and within the limits of Client's instructions, if any. The Company's sole responsibility is to its Client and this document does not exonerate parties to a transaction from exercising all their rights and obligations under the transaction documents. This document cannot be reproduced except in full, without prior written approval of the Company. Any unauthorized alteration, forgery or falsification of the content or appearance of this document is unlawful and offenders may be prosecuted to the fullest extent of the law. Unless otherwise stated the results shown in this test report refer only to the sample(s) tested and such sample(s) are retained for 30 days only.  
**Attention: To check the authenticity of testing /inspection report & certificate, please contact us at telephone: (86-755) 8307 1443, or email: CN.Doccheck@sgs.com**

Room 105, Building A, Xixiang Technology Industrial Park, No. 50 Fengqiang Road, Xixiang Community, Fuyong Street, Bao'an District, Shenzhen, China 518103 t (86-755) 26012053 f (86-755) 26710594 www.sgs.com  
中国·深圳·宝安区福永街道新田社区凤塘大道50号鑫龙科技工业园A栋105室 邮编: 518103 t (86-755) 26012053 f (86-755) 26710594 sgs.china@sgs.com

### Conducted transient immunity



### Bulk Current Injection(20MHz-400MHz)

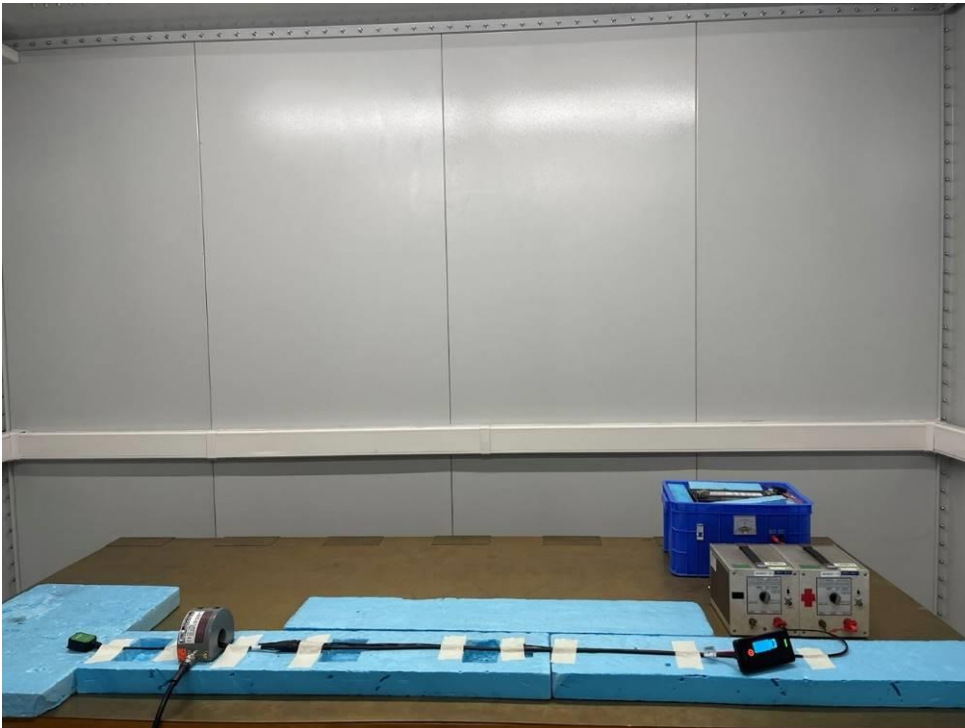

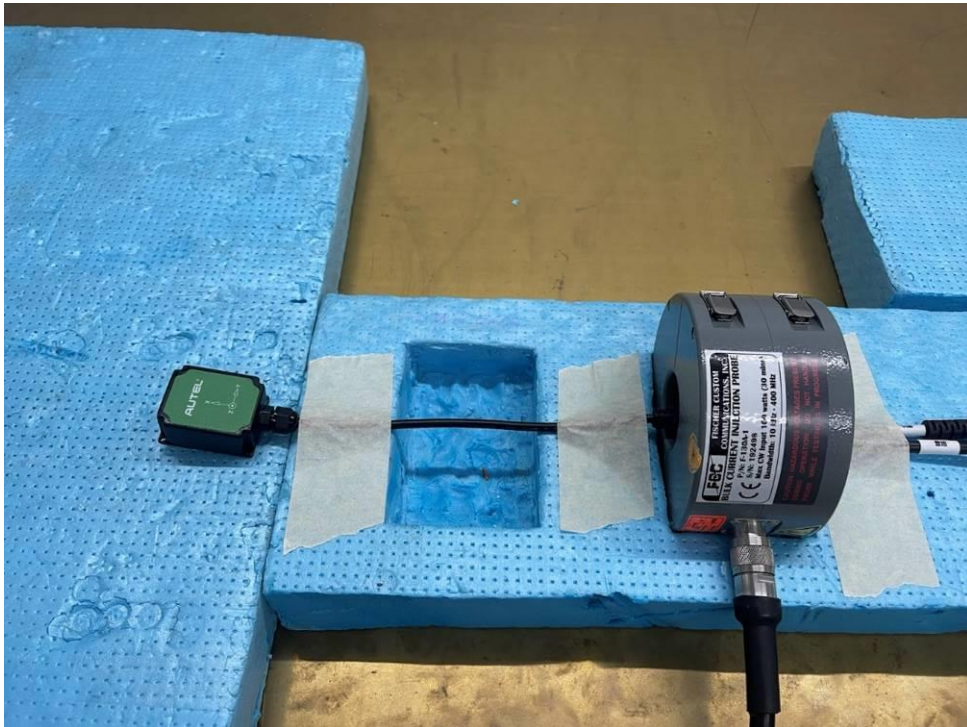
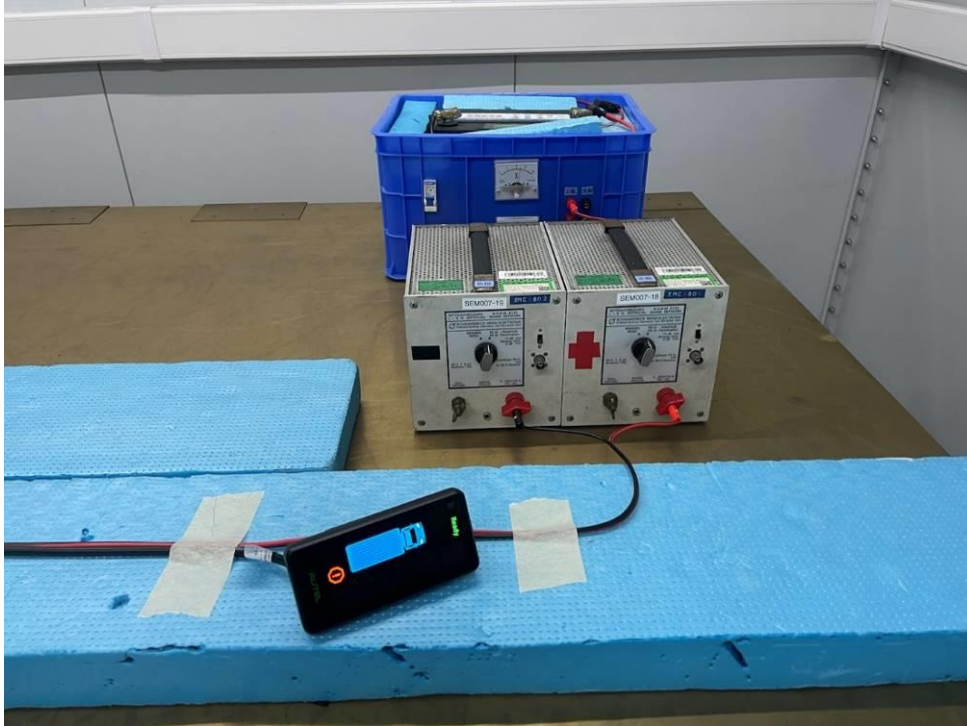



### Radiation immunity-ALSE(400MHz-2GHz)

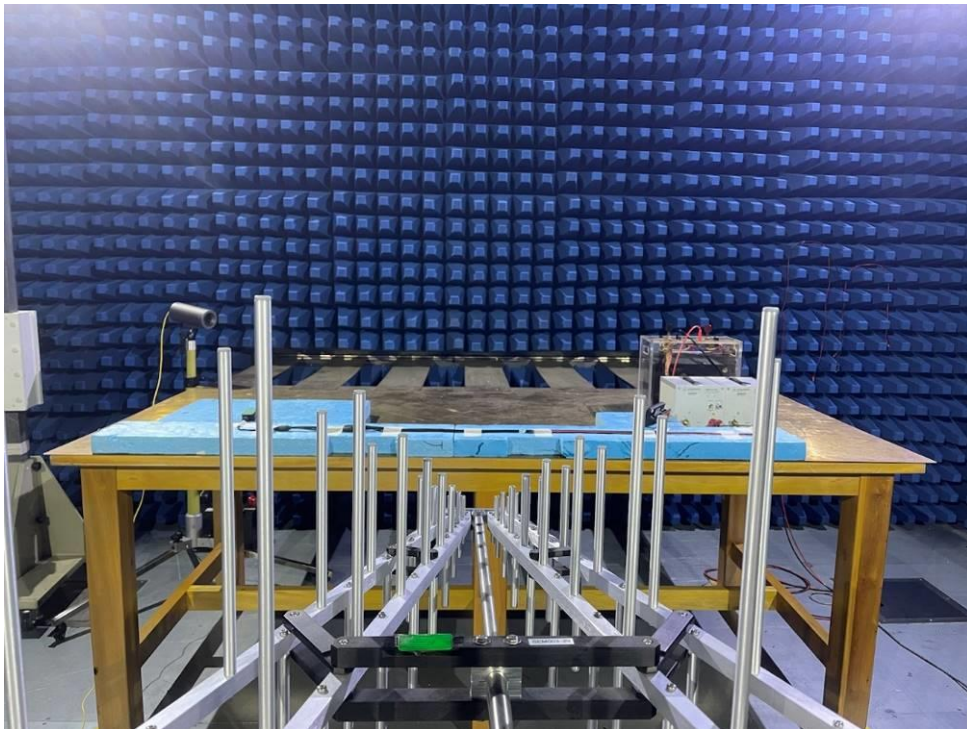

Unless otherwise agreed in writing, this document is issued by the Company subject to its General Conditions of Service printed overleaf, available on request or accessible at <http://www.sgs.com/en/Terms-and-Conditions.aspx> and, for electronic format documents, subject to Terms and Conditions for Electronic Documents at <http://www.sgs.com/en/Terms-and-Conditions/Terms-e-Documents.aspx>. Attention is drawn to the limitation of liability, indemnification and jurisdiction issues defined therein. Any holder of this document is advised that information contained hereon reflects the Company's findings at the time of its intervention only and within the limits of Client's instructions, if any. The Company's sole responsibility is to its Client and this document does not exonerate parties to a transaction from exercising all their rights and obligations under the transaction documents. This document cannot be reproduced except in full, without prior written approval of the Company. Any unauthorized alteration, forgery or falsification of the content or appearance of this document is unlawful and offenders may be prosecuted to the fullest extent of the law. Unless otherwise stated the results shown in this test report refer only to the sample(s) tested and such sample(s) are retained for 30 days only.  
**Attention:** To check the authenticity of testing/inspection report & certificate, please contact us at telephone: (86-755) 8307 1443, or email: [CN.Doccheck@sgs.com](mailto:CN.Doccheck@sgs.com)

SGS-CSTC Standards Technical Services Co., Ltd.  
 Shenzhen Branch Testing & Calibration Laboratory

Room 105, Building A, Xixiang Technology Industrial Park, No. 50 Fenggang Road, Xixiang Community, Fuyong Street, Bao'an District, Shenzhen, China 518103 t (86-755) 26012053 f (86-755) 26710594 www.sgs.com.cn  
 中国·深圳·宝安区福永街道新田社区凤塘大道50号鑫龙科技园A栋105室 邮编: 518103 t (86-755) 26012053 f (86-755) 26710594 sgs.china@sgs.com



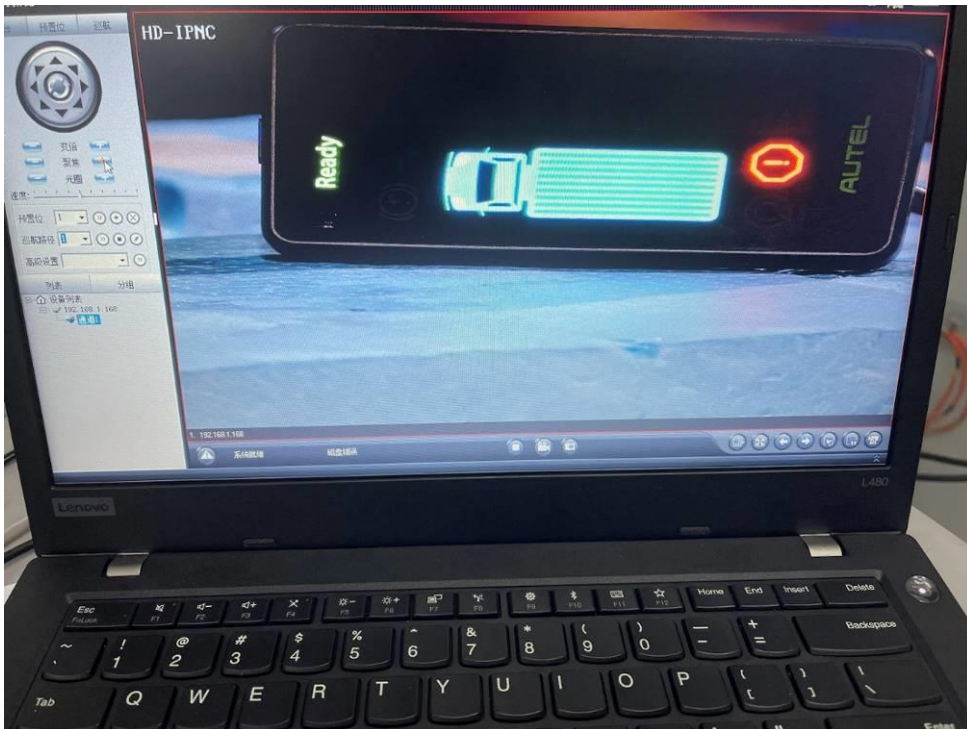
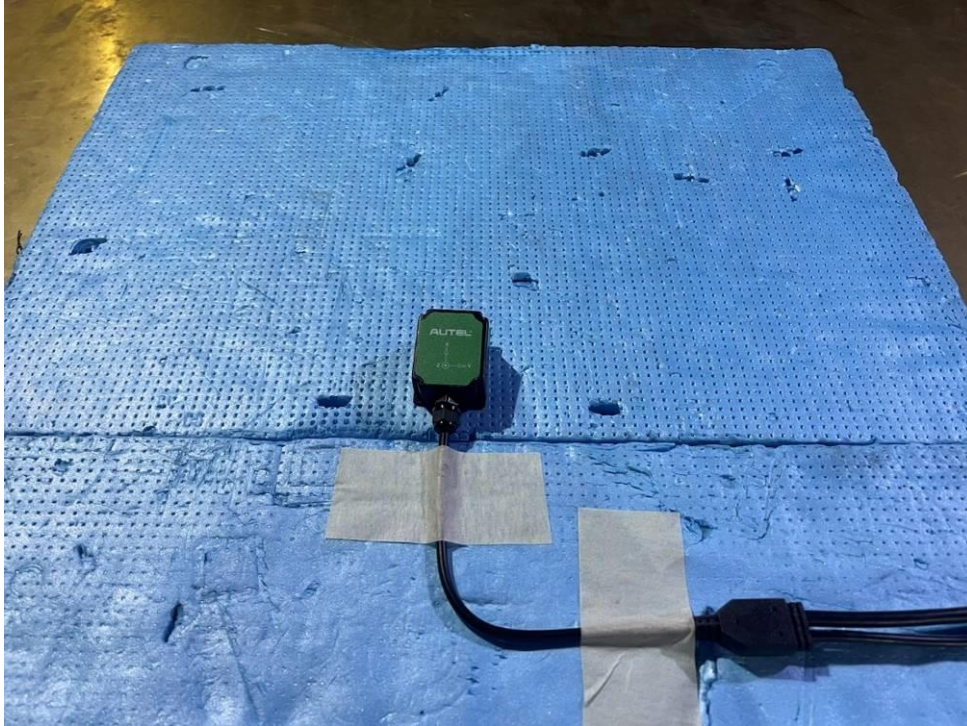

## 9 EUT Constructional Details (EUT Photos)



Unless otherwise agreed in writing, this document is issued by the Company subject to its General Conditions of Service printed overleaf, available on request or accessible at <http://www.sgs.com/en/Terms-and-Conditions.aspx> and, for electronic format documents, subject to Terms and Conditions for Electronic Documents at <http://www.sgs.com/en/Terms-and-Conditions/Terms-e-Documents.aspx>. Attention is drawn to the limitation of liability, indemnification and jurisdiction issues defined therein. Any holder of this document is advised that information contained hereon reflects the Company's findings at the time of its intervention only and within the limits of Client's instructions, if any. The Company's sole responsibility is to its Client and this document does not exonerate parties to a transaction from exercising all their rights and obligations under the transaction documents. This document cannot be reproduced except in full, without prior written approval of the Company. Any unauthorized alteration, forgery or falsification of the content or appearance of this document is unlawful and offenders may be prosecuted to the fullest extent of the law. Unless otherwise stated the results shown in this test report refer only to the sample(s) tested and such sample(s) are retained for 30 days only.

**Attention:** To check the authenticity of testing /inspection report & certificate, please contact us at telephone: (86-755) 8307 1443, or email: [CN.Doccheck@sgs.com](mailto:CN.Doccheck@sgs.com)

SGS-CSTC Standards Technical Services Co., Ltd.  
Shenzhen Branch Testing & Calibration Laboratory

Room 105, Building A, Xixiang Technology Industrial Park, No. 50 Fengtang Road, Xixiang Community, Fuyong Street, Bao'an District, Shenzhen, China 518103 t (86-755) 26012053 f (86-755) 26710594 www.sgsgroup.com.cn  
中国·深圳·宝安区福永街道新田社区凤塘大道50号鑫龙科技园A栋105室 邮编: 518103 t (86-755) 26012053 f (86-755) 26710594 sgs.china@sgs.com



Unless otherwise agreed in writing, this document is issued by the Company subject to its General Conditions of Service printed overleaf, available on request or accessible at <http://www.sgs.com/en/Terms-and-Conditions.aspx> and, for electronic format documents, subject to Terms and Conditions for Electronic Documents at <http://www.sgs.com/en/Terms-and-Conditions/Terms-e-Documents.aspx>. Attention is drawn to the limitation of liability, indemnification and jurisdiction issues defined therein. Any holder of this document is advised that information contained hereon reflects the Company's findings at the time of its intervention only and within the limits of Client's instructions, if any. The Company's sole responsibility is to its Client and this document does not exonerate parties to a transaction from exercising all their rights and obligations under the transaction documents. This document cannot be reproduced except in full, without prior written approval of the Company. Any unauthorized alteration, forgery or falsification of the content or appearance of this document is unlawful and offenders may be prosecuted to the fullest extent of the law. Unless otherwise stated the results shown in this test report refer only to the sample(s) tested and such sample(s) are retained for 30 days only.

**Attention:** To check the authenticity of testing /inspection report & certificate, please contact us at telephone: (86-755) 8307 1443, or email: [CN.Doccheck@sgs.com](mailto:CN.Doccheck@sgs.com)

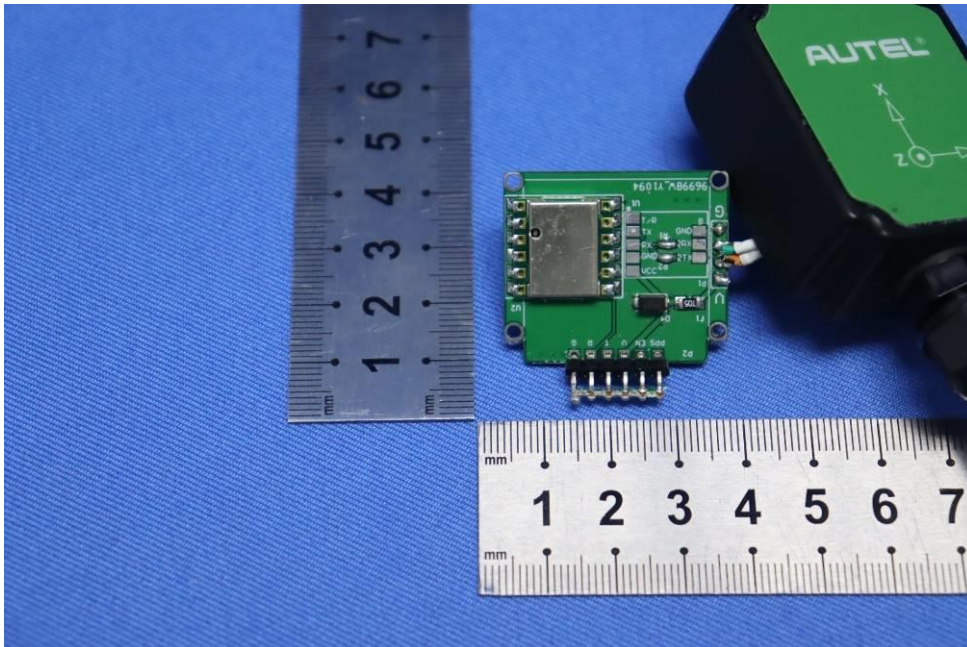
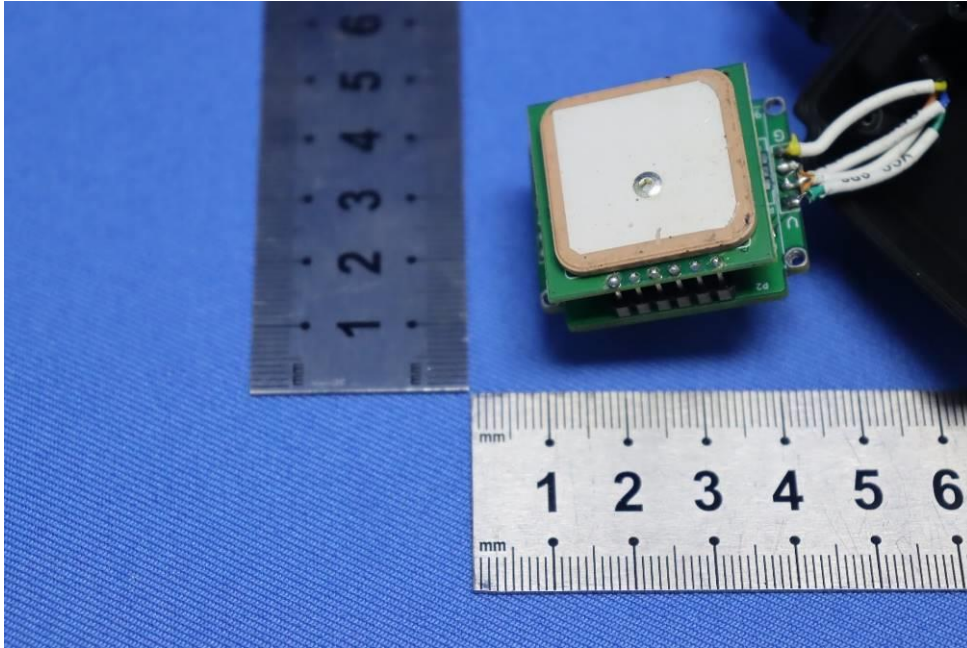

Unless otherwise agreed in writing, this document is issued by the Company subject to its General Conditions of Service printed overleaf, available on request or accessible at <http://www.sgs.com/en/Terms-and-Conditions.aspx> and, for electronic format documents, subject to Terms and Conditions for Electronic Documents at <http://www.sgs.com/en/Terms-and-Conditions/Terms-e-Documents.aspx>. Attention is drawn to the limitation of liability, indemnification and jurisdiction issues defined therein. Any holder of this document is advised that information contained hereon reflects the Company's findings at the time of its intervention only and within the limits of Client's instructions, if any. The Company's sole responsibility is to its Client and this document does not exonerate parties to a transaction from exercising all their rights and obligations under the transaction documents. This document cannot be reproduced except in full, without prior written approval of the Company. Any unauthorized alteration, forgery or falsification of the content or appearance of this document is unlawful and offenders may be prosecuted to the fullest extent of the law. Unless otherwise stated the results shown in this test report refer only to the sample(s) tested and such sample(s) are retained for 30 days only.

**Attention:** To check the authenticity of testing/inspection report & certificate, please contact us at telephone: (86-755) 8307 1443, or email: [CN.Doccheck@sgs.com](mailto:CN.Doccheck@sgs.com)

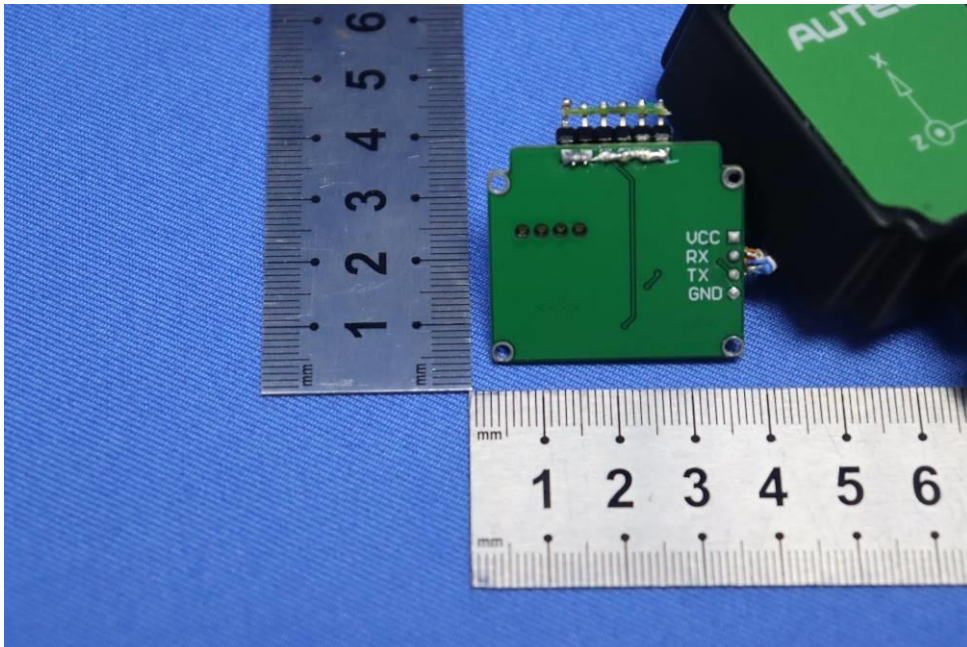
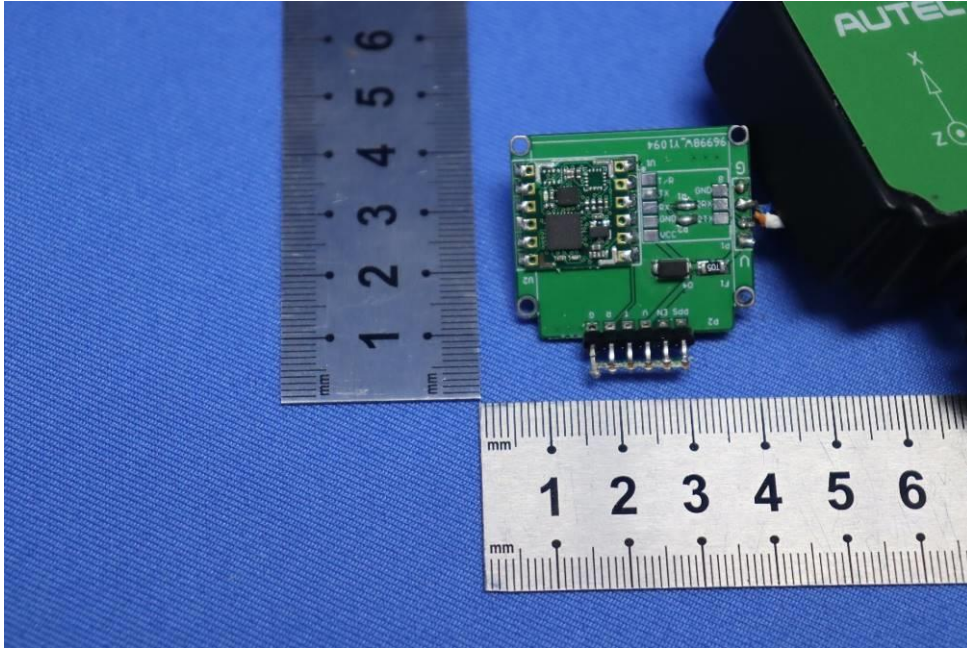

Unless otherwise agreed in writing, this document is issued by the Company subject to its General Conditions of Service printed overleaf, available on request or accessible at <http://www.sgs.com/en/Terms-and-Conditions.aspx> and, for electronic format documents, subject to Terms and Conditions for Electronic Documents at <http://www.sgs.com/en/Terms-and-Conditions/Terms-e-Documents.aspx>. Attention is drawn to the limitation of liability, indemnification and jurisdiction issues defined therein. Any holder of this document is advised that information contained hereon reflects the Company's findings at the time of its intervention only and within the limits of Client's instructions, if any. The Company's sole responsibility is to its Client and this document does not exonerate parties to a transaction from exercising all their rights and obligations under the transaction documents. This document cannot be reproduced except in full, without prior written approval of the Company. Any unauthorized alteration, forgery or falsification of the content or appearance of this document is unlawful and offenders may be prosecuted to the fullest extent of the law. Unless otherwise stated the results shown in this test report refer only to the sample(s) tested and such sample(s) are retained for 30 days only.

**Attention:** To check the authenticity of testing /inspection report & certificate, please contact us at telephone: (86-755) 8307 1443, or email: [CN.Doccheck@sgs.com](mailto:CN.Doccheck@sgs.com)

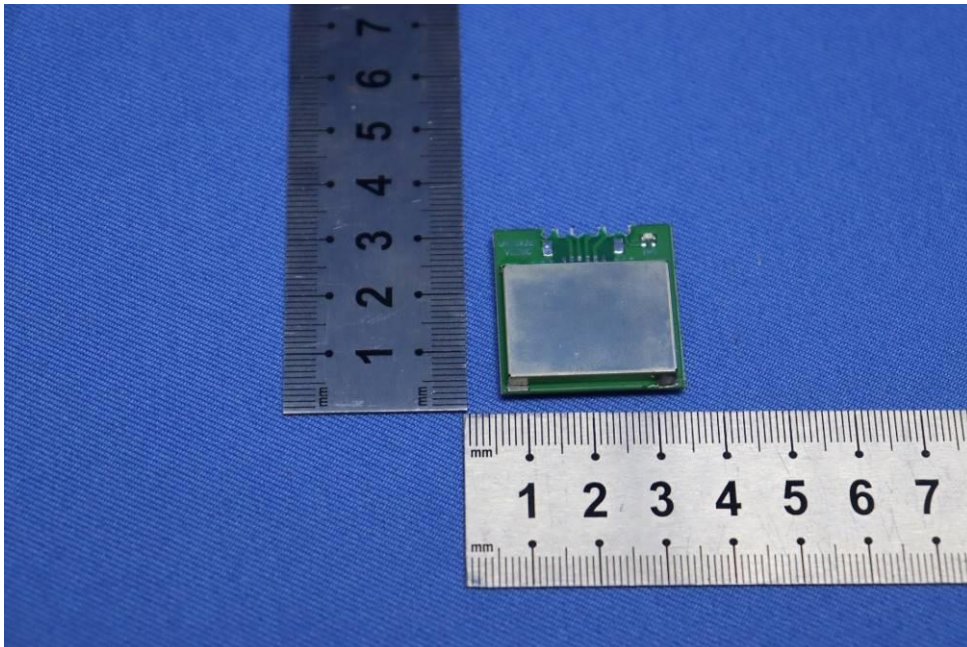
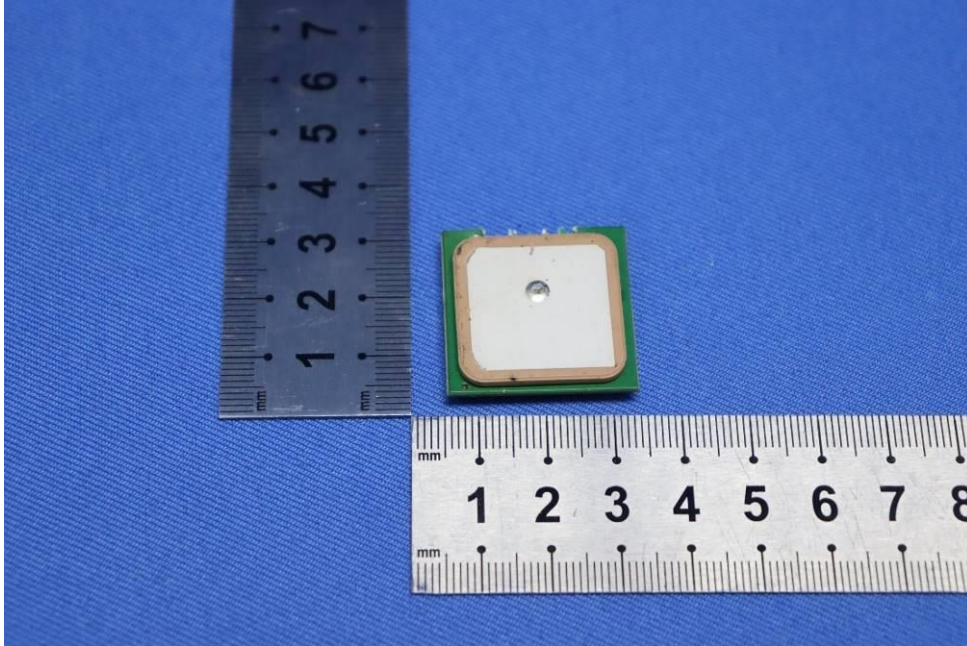

Unless otherwise agreed in writing, this document is issued by the Company subject to its General Conditions of Service printed overleaf, available on request or accessible at <http://www.sgs.com/en/Terms-and-Conditions.aspx> and, for electronic format documents, subject to Terms and Conditions for Electronic Documents at <http://www.sgs.com/en/Terms-and-Conditions/Terms-e-Documents.aspx>. Attention is drawn to the limitation of liability, indemnification and jurisdiction issues defined therein. Any holder of this document is advised that information contained hereon reflects the Company's findings at the time of its intervention only and within the limits of Client's instructions, if any. The Company's sole responsibility is to its Client and this document does not exonerate parties to a transaction from exercising all their rights and obligations under the transaction documents. This document cannot be reproduced except in full, without prior written approval of the Company. Any unauthorized alteration, forgery or falsification of the content or appearance of this document is unlawful and offenders may be prosecuted to the fullest extent of the law. Unless otherwise stated the results shown in this test report refer only to the sample(s) tested and such sample(s) are retained for 30 days only.  
**Attention:** To check the authenticity of testing /inspection report & certificate, please contact us at telephone: (86-755) 8307 1443, or email: [CN.Doccheck@sgs.com](mailto:CN.Doccheck@sgs.com)

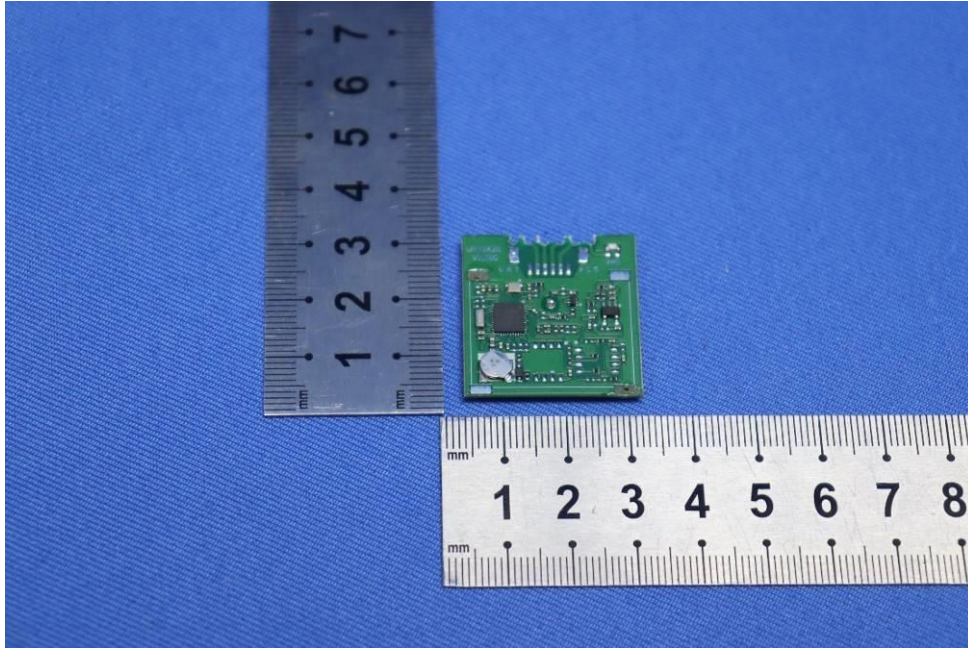

- End of the Report -

	Autel Intelligent Automobile Corp., Ltd.	Type:ASI-100 Information document No.: IF_ASI-100_R10.06_00
		Date: 25.08.2022
		Pages: Page 1 of 10

Application for Type Approval Pursuant  
To ECE R10.06  
Relating to Electromagnetic compatibility of an ESA

For: Autel Intelligent Automobile Corp., Ltd.

Component: IMU module

Type: ASI-100

Place: Floor 8, Floor 7 and Floor 4, Building B1, Zhiyuan, No.1001 Xueyuan Avenue, Changyuan Community, Taoyuan Road, Nanshan District Shenzhen City, Guangdong Province, P.R. China

Post Code: 518055

	Autel Intelligent Automobile Corp., Ltd.	Type:ASI-100 Information document No.: IF_ ASI-100_R10.06_00
		Date: 25.08.2022
		Pages: Page 2 of 10

- |      |  |   |
|------|--|---|
| 1.   | Make (trade name of manufacturer)  | Autel   |
| 2.   | Type   | ASI-100   |
| 2.1. | Variant  | n.a.  |
| 3.   | Means of identification of type, if marked on the component/separate technical unit                          | Type Designation  |
| 3.1. | Location of that marking   | On the bottom of the product  |
| 4.   | Name and address of manufacturer   | Autel Intelligent Automobile Corp., Ltd.<br><br>Floor 8, Floor 7 and Floor 4, Building B1, Zhiyuan, No.1001 Xueyuan Avenue, Changyuan Community, Taoyuan Road, Nanshan District Shenzhen City, Guangdong Province, P.R. China Post Code: 518055 |
|      | Name and address of authorized representative, if any  | n.a.  |
| 5.   | In the case of components and separate technical units, location and method of affixing of the approval mark | adhesive label on the bottom of the product   |
| 6.   | Address (es) of assembly plant(s)  | Autel Intelligent Automobile Corp., Ltd.<br><br>Workroom 103 104. 105. 106. 108. 1st Floor, Building A9, Tianliao Industrial Zone, Taoyuan Road, Nanshan District, Shenzhen City, Guangdong Province, P.R. China                                |
| 7.   | This ESA shall be approved as a  | Component   |
| 8.   | Any restrictions of use and conditions for fitting   | Supports installation in any direction (sensor inclination should not exceed 30°).  |

	Autel Intelligent Automobile Corp., Ltd.	Type:ASI-100 Information document No.: IF_ASI-100_R10.06_00
		Date: 25.08.2022
		Pages: Page 3 of 10

9.	Electrical system rated voltage	DC12V/24V negative grounded
10.	Charger: on board/external	n.a.
11.	Charging current: direct current/alternating current (number of phases/frequency)	n.a.
12.	Maximal nominal current (in each mode if necessary)	n.a.
13.	Nominal charging voltage	n.a.
14.	Basic ESA interface functions:	n.a.
15.	Minimum Rsce value (see paragraph 7.11. of this Regulation)	n.a.

## List of Contents

Appendix 1: Description of the ESA -----	4
Attachment 1: Photo of the ESA-----	6
Attachment 2: Dimensional drawing -----	7
Attachment 3: Photo of the PCB -----	8
Attachment 4: Electric Circuit Diagram -----	9
Attachment 5: Bill of Materials -----	10

This information document consists of pages 4 to 10 including Appendix and Attachments

	Autel Intelligent Automobile Corp., Ltd.	Type:ASI-100 Information document No.: IF_ASI-100_R10.06_00
		Date: 25.08.2022
		Pages: Page 4 of 10

#### Appendix 1: Description of the ESA

1. Input range : DC5V via IMU DC12V/24V power supply
2. Consumption power : <0.25W
3. Resource of X-tal or oscillator : n.a.
4. Main dimensions : 40X50X21.9mm
- 5 Description/Manual:
  - 1) Voltage: 5V
  - 2) Current: <50mA
  - 3) .Measurement dimensions: acceleration: 3 dimensions, angular velocity: 3 dimensions, angle: 3 dimensions, GPS: 3 dimensions
  - 4) Range: XZ axis angle  $\pm 180^\circ$ , Y axis angle  $\pm 90^\circ$ .
  - 5) Stability: Acceleration: 0.01g, angular velocity 0.05°/s.
  - 6) Attitude measurement stability: 0.01°.
  - 7) Angle accuracy: static 0.05°, dynamic 0.1°.
  - 8) Data output content: time, acceleration, angular velocity, angle, latitude and longitude, ground speed.
  - 9) Data output frequency 0.2Hz~200Hz.
  - 10) Data interface: serial port (TTL level, baud rate supports 4800, 9600, 19200, 38400, 57600, 115200, 230400, 460800, 921600)
  - 11) GPS: GPS+Beidou signal
  - 12) Applicable environment: dynamic and static.
  - 13) Antenna: Built-in.

	Autel Intelligent Automobile Corp., Ltd.	Type:ASI-100 Information document No.: IF_ASI-100_R10.06_00
		Date: 25.08.2022
		Pages: Page 5 of 10

14) Inertial Navigation: Built-in inertial navigation algorithm

Content			
C/A code	1.023mhz stream		
Receive band	BDS/GPS/GLONASS/GALILEO/QZSS/SBAS		
Receive channel	3-channel RF, support BDS, GPS and GLONASS simultaneous reception		
S11SWR	≤1.3	S22SWR	≤1.3
S2Log Mag	≥20.0dB	S11Smith	50Ω±5%
Horizontal position accuracy	<2.5m{autonomous}<2m{sbas} (cep,50%,24h static, signal strength, -130dbm, about 6 available satellites)		
Rate	<0.1m/s		<0.5Degrees
Timing accuracy	30ns	Reference coordinate system	WGS-84
Altitude range	50000m	Max speed	50000m/s
Acceleration:	≤4g		
Track sensitivity	-162dbm	Capture sensitivity	-148dbm
Cold start sensitivity	-148dmb	Hot start sensitivity	-156dbm
Cold start time	35s	Warm start time	32S
Hot start time	1s		
Clock pulse	0.25Hz~1Khz		
Location rate	1Hz~110Hz (Default 1Hz) UART/TTLPort interface		

Inertial measurement unit ( IMU for short) is a device that measures the three-axis attitude angle (or angular rate) and acceleration of an object

	Autel Intelligent Automobile Corp., Ltd.	Type:ASI-100
		Information document No.: IF_ASI-100_R10.06_00
		Date: 25.08.2022
		Pages: Page 6 of 10

Attachment 1: Photo of the ESA



	Autel Intelligent Automobile Corp., Ltd.	Type:ASI-100 Information document No.: IF_ASI-100_R10.06_00
		Date: 25.08.2022
		Pages: Page 7 of 10

Attachment 2: Dimensional drawing

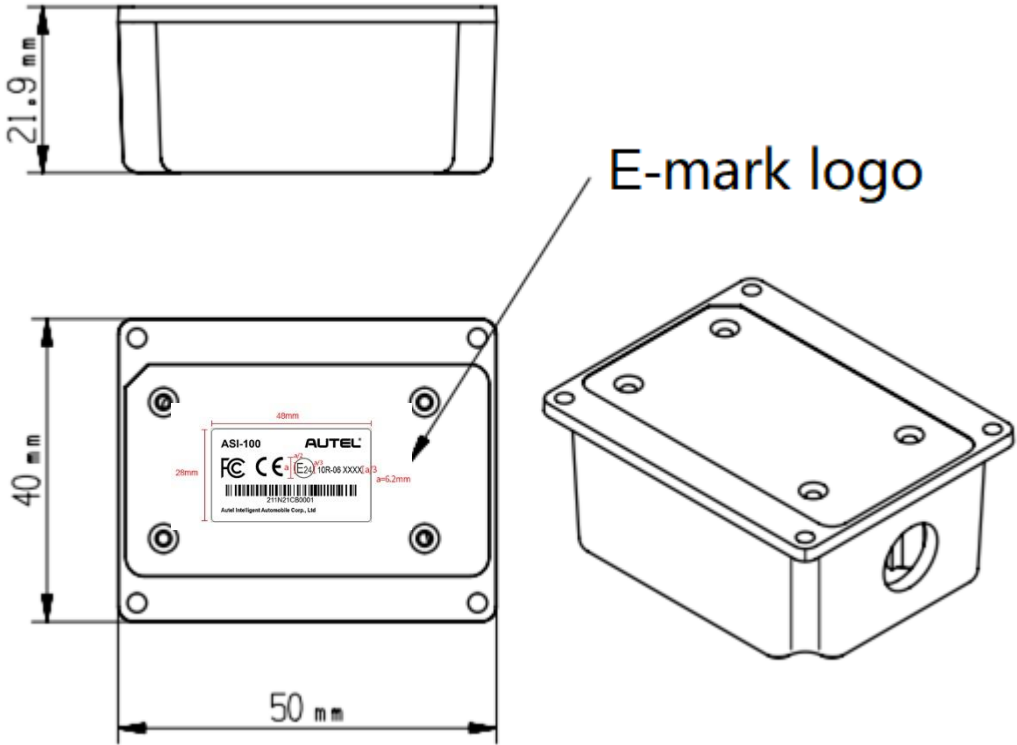



Autel Intelligent Automobile Corp., Ltd.

Type:ASI-100  
Information document No.: IF\_ASI-100\_R10.06\_00

Date: 25.08.2022

Pages: Page 8 of 10

Attachment 3: Photo of the PCB

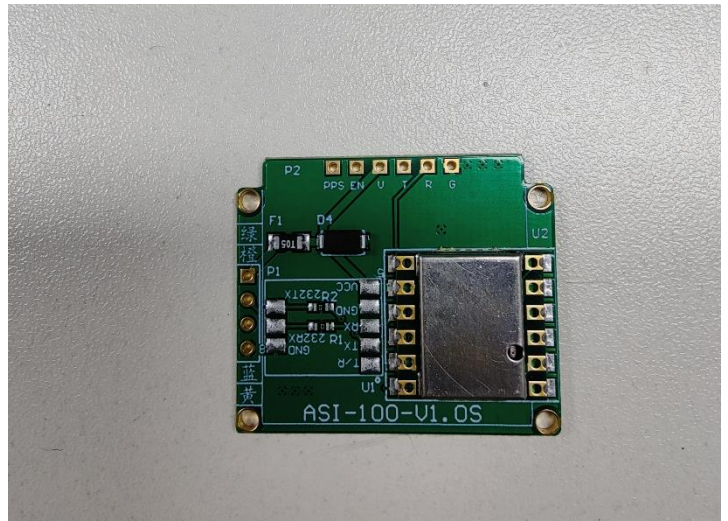
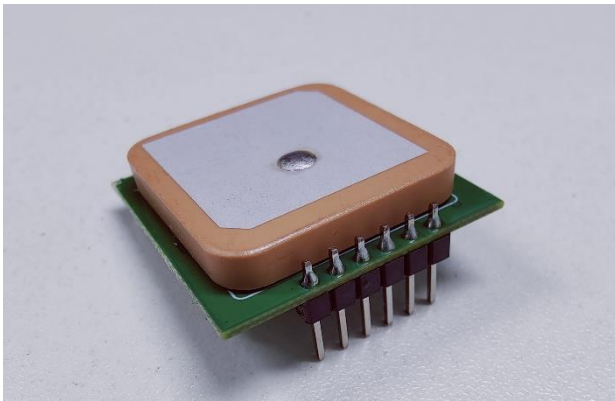
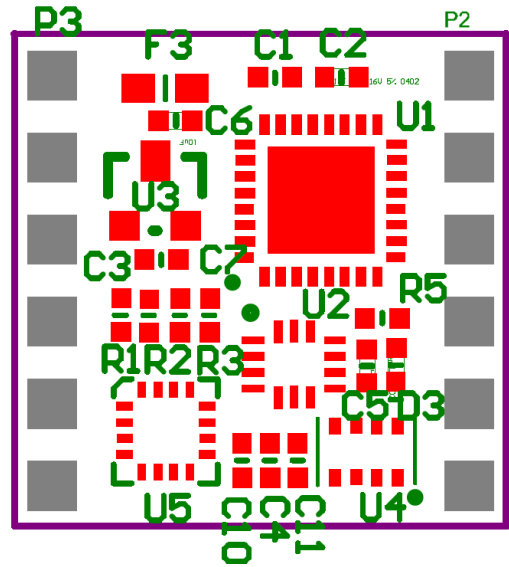
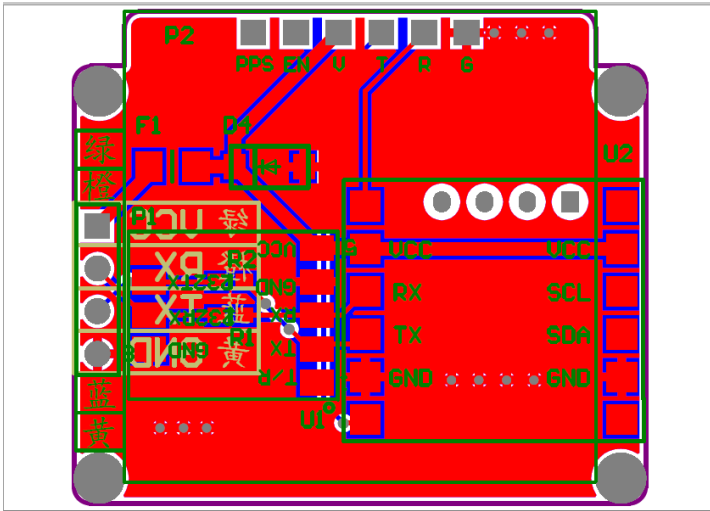



	Autel Intelligent Automobile Corp., Ltd.	Type:ASI-100 Information document No.: IF_ASI-100_R10.06_00
		Date: 25.08.2022
		Pages: Page 10 of 10

Attachment 5: Bill of Materials

SMAJ5.0A MDD	Zener Diode	D4	sma	D Zener	1
500MA 保险丝	Resistor	F1	1206	Res2	1
Header 4	Header, 4-Pin	P1	HDR1X4	Header 4	1
GPS-Module	Header, 6-Pin	P2	GPS	Header 6	1
0R	Resistor	R1, R2	0603	Res2	2
RS232/485		U1	232-485	RS232/485	1
JY-901Module	JY-901	U2	JY901S	JY-901	1



# NSAI

## ECE TYPE-APPROVAL CERTIFICATE



Concerning:<sup>2</sup>

- Approval granted
- ~~Approval extended~~
- ~~Approval refused~~
- ~~Approval withdrawn~~
- ~~Production definitively discontinued~~

Of a type of ~~vehicle~~/component/~~separate technical unit~~<sup>2</sup> with regard to Regulation No. 10.  
Of a type of electrical/electronic sub-assembly<sup>2</sup> with regard to Regulation No.10.

Approval No: **E24\*10R06/02\*5467\*00**



Reason for extension: -N/A

1. Make (trade name of manufacturer): **XFD**
2. Type and general commercial description: **MOIS DSP 00**  
**MOIS Display**
3. Means of identification of type, if marked on the ~~vehicle~~/  
component/~~separate technical unit~~<sup>2</sup>: **Approval mark**
- 3.1 Location of that marking: **See Drawings of the ESA**
4. Category of vehicle: **N/A**
5. Name and address of manufacturer: **Shenzhen Xiaofeida Electronics Co., Ltd.**  
**Room 901, Unit 1, Fucheng Digital**  
**Innovation Park, 15-5, Shijing Road,**  
**Fumin Community, Fucheng Street,**  
**Longhua District, Shenzhen City,**  
**Guangdong Province, China**
6. In the case of components and separate technical units,  
location and method of affixing of the approval mark: **See Drawings of the ESA**
7. Address(es) of assembly plant(s): **Shenzhen Xiaofeida Electronics Co., Ltd.**  
**Room 901, Unit 1, Fucheng Digital**  
**Innovation Park, 15-5, Shijing Road,**  
**Fumin Community, Fucheng Street,**  
**Longhua District, Shenzhen City,**  
**Guangdong Province, China**



# NSAI

Approval No: E24\*10R06/02\*5467\*00

8. Additional information (where applicable): *See appendix below*
9. Technical service responsible for carrying out the tests: *CETOC Technical Service srl Via della Bufalotta, 374, 00139 Roma*
10. Date of test report: *02.02.2024*
11. Number of test report: *CN-112-17-207-COM24-11004-IR*
12. Remarks (if any): *See Appendix below*
13. Place: *Dublin*
14. Date: *07<sup>th</sup> March 2024*
15. Signature:  
16. The index to the information package lodged with the approval authority, which may be obtained on Request, is attached.

- 
1. Distinguishing number of the country which issued/extended/refused or withdrawn approval. (see Regulation, provisions on approval).
  2. Strike out what does not apply.



# NSAI

Approval No: E24\*10R06/02\*5467\*00

## Appendix

To type-approval communication concerning the type approval of an electrical/electronic sub-assembly under Regulation No.10.

1. Additional information
  - 1.1. Electrical system rated voltage: *DC 12V/24V, negative ground*
  - 1.2. This ESA can be used on any vehicle type with the following restrictions: *See manufacturer's specifications.*
    - 1.2.1 Installation conditions, if any: *See manufacturer's specifications.*
  - 1.3. This ESA can only be used on the following vehicle types: *N/A*
    - 1.3.1 Installation conditions, if any: *N/A*
  - 1.4. The specific test method(s) used and the frequency ranges covered to determine immunity were: *Bulk Current Injection Method:  
Frequency: (20 – 400 MHz)  
Absorber Chamber Test:  
Frequency: (400 – 2000 MHz)*
  - 1.5. Laboratory accredited to ISO 17025 and recognized by the Approval Authority responsible for carrying out the tests: *CETOC Technical Service srl*
2. Remarks: *N/A*

Appendix to type-approval communication concerning the type approval of a vehicle under Regulation No.10.

1. Additional information
2. Electrical system rated voltage: *N/A*
3. Type of bodywork: *N/A*
4. List of electronic systems installed in the tested vehicle(s) not limited to the items in the information document: *N/A*
  - 4.1. Vehicle equipped with 24 GHz short-range radar equipment (yes/no/optional)<sup>2</sup>: *N/A*
5. Laboratory accredited to ISO 17025 and recognized by the Approval Authority responsible for carrying out the tests: *N/A*
6. Remarks: *N/A*

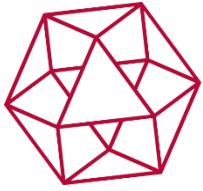

# NSAI

Approval No: E24\*10R06/02\*5467\*00

## Index to the Information Package

Date of issue:	<i>07<sup>th</sup> March 2024</i>
Date of latest amendment:	<i>N/A</i>
Reason for extension/revision:	<i>N/A</i>
1. Additional conditions, and advisory notes on legal alternatives.	
2. Test report(s)	
- numbers(s):	<i>CN-112-17-207-COM24-11004-IR</i>
- date of issue:	<i>02.02.2024</i>
- date of latest amendment:	<i>N/A</i>
3. Information document	
- number(s):	<i>MOIS DSP 00-00</i>
- date of issue:	<i>29.01.2024</i>
- date of latest amendment:	<i>N/A</i>
Documentation:	<i>28 pages</i>



# NSAI

Approval No: E24\*10R06/02\*5467\*00

## Appendix: **Additional conditions, and advisory notes on legal alternatives**

### A: Additional conditions:

1. The attached technical report, with any of its attachments, forms part of this Type Approval certificate.
2. Each device from series production shall be to the measurements specified in the attached drawings, and shall be manufactured only from the materials specified in the Approval documents.
3. Changes in the type are permitted only with the explicit permission of NSAI. Breaches of this requirement will lead to a withdrawal of the Type Approval, and in addition may be subject to criminal prosecution.
4. At regular intervals, any tests or associated checks prescribed by the applicable legislation to verify continued conformity with the approved type shall be carried out. The manufacturer shall demonstrate compliance with this by submitting to NSAI evidence of adequate arrangements and documented control plans for each type approved.
5. Any set of samples or test pieces showing evidence of non-conformity shall give rise to further sampling and testing and all steps shall be taken to restore conformity of production.
6. This Type Approval will expire when it is surrendered by the holder, or withdrawn by NSAI, or when the approved type no longer conforms to legal requirements. The recall of the Type Approval can be issued by NSAI when the conditions required for the issuing or continuation of the Type Approval are no longer current, or when the Approval holder is in breach of the duties attached to the Type Approval, or when it is established that the approved type no longer meets the requirements of traffic safety.
7. Changes in the company name, address or manufacturing site, as well as in any of the sales or other agents specified in the issuing of the approval must immediately be notified to NSAI.
8. The duties imposed by the issuing of this certificate are not transferable. The legal protection of third parties is not affected by this certificate.
9. When the manufacture or sale of the system, component or separate technical unit has not been started within one year of the date of issue of this certificate, then NSAI is to be informed. This requirement also applies when the manufacture or sale has been halted for more than one year, or when it ought to have been halted for more than one year. The initial commencement of manufacture or sale, or the resumption of manufacture or sale, shall then be notified to NSAI within one month of commencement or resumption.

### B: Legal Options:

Any objection to the requirements set out in this certificate shall be made within one month of the date of issue. The objection shall be made, in writing, to NSAI in Dublin.



CETOC TS

CETOC Technical Service srl  
Via della Bufalotta, 374,  
00139 Roma

Inspection Report Nr.: CN-112-17-207-COM24-11004-IR  
Manufacturer: Shenzhen Xiaofeida Electronics Co., Ltd.  
Type: MOIS DSP 00

This inspection report shall not be reproduced except in full, without written approval of the technical service.



ISP N° 0184 E

Membro degli Accordi di Mutuo Riconoscimento  
EA, IAF e ILAC

Signatory of EA, IAF and ILAC  
Mutual Recognition Agreements

## Electromagnetic Compatibility – ESA

### 0. Legislation:

0.1. Requirements according to : UNECE Regulation 10.06 to Supplement 2

### 1. General

1.1. Reason for Inspection Report : New approval / ~~Extension of approval~~ / ~~Test report only~~ / COP  
1.2. Manufacturer's Representative(s) : No attendance  
1.3. CETOC TS Representative(s) : Xiaoli Li  
1.4. Location of Test : GuangZhou ShunTai Quality Technical Service Co., Ltd.  
Room 206A, 2F, 4# Plant, No.63 Punan Road, Huangpu District,  
Guangzhou, China, 510760  
1.5. Data of test : 01/02/2024

### 2. Manufacturer Details

2.1. Make : XFD  
2.2. Type : MOIS DSP 00  
2.3. Variant/Version : D222-V7, D222-V8  
2.4. Commercial Name : MOIS Display  
2.5. Category : Component  
2.6. Name and Address of manufacturer : Shenzhen Xiaofeida Electronics Co., Ltd.  
Room 901, Unit 1, Fucheng Digital Innovation Park, 15-5, Shijing  
Road, Fumin Community, Fucheng Street, Longhua District,  
Shenzhen City, Guangdong Province, China

### 3. Conclusion:

3.1. Final conclusion of the inspection: : The above mentioned type was tested in accordance with the above mentioned legislation and was found to comply in all respects. This Inspection report relates only to the items tested.

Signature :

*Xiaoli Li*

*Marco Pagliari*

Name : Xiaoli Li

Marco Pagliari

Position : Type Approval Engineer

Tech. Mgr.

Place and date : Guangzhou, 02/02/2024

Roma, 02/02/2024

### 4. List of annexes:

Appendix Nr.	Page Nr.	Subject
Appendix 1	2	: Test report history
Appendix 2	2	: General specification
Appendix 3	4	: Inspection results
Appendix 4	12	: Test results



**CETOC TS**

CETOC Technical Service srl  
Via della Bufalotta, 374,  
00139 Roma

Inspection Report Nr.: CN-112-17-207-COM24-11004-IR  
Manufacturer: Shenzhen Xiaofeida Electronics Co., Ltd.  
Type: MOIS DSP 00

This inspection report shall not be reproduced except in full, without written approval of the technical service.



ISP N° 0184 E

Membro degli Accordi di Mutuo Riconoscimento  
EA, IAF e ILAC

Signatory of EA, IAF and ILAC  
Mutual Recognition Agreements

### APPENDIX 1 - TEST REPORT HISTORY

List this report and previous reports, with extension details.

Inspection Report Number	Reason for Extension	Date of Issue
CN-112-17-207-COM24-11004-IR	N/A	02/02/2024

### APPENDIX 2 – GENERAL SPECIFICATION

1. **Worst Case Rationale** : All variants have the same appearance, Function, PCB layout, electronic circuit design and the same component of PCB with the type, the difference among them are the model name and display effect of the different model.  
Model MOIS DSP 00 was tested.

2. **Significant Interpretations, Alternative Test Methods, New Technologies** : N/A

#### 3. Summary of test results

3.1. Applicability :

	PASS	FAIL	N/A
Radiated Emissions:	<input checked="" type="checkbox"/>	<input type="checkbox"/>	<input type="checkbox"/>
Radiated Immunity:	<input checked="" type="checkbox"/>	<input type="checkbox"/>	<input type="checkbox"/>
BCI Immunity:	<input checked="" type="checkbox"/>	<input type="checkbox"/>	<input type="checkbox"/>
Free Field Immunity:	<input checked="" type="checkbox"/>	<input type="checkbox"/>	<input type="checkbox"/>
150 mm Stripline Immunity:	<input type="checkbox"/>	<input type="checkbox"/>	<input checked="" type="checkbox"/>
800 mm Stripline Immunity:	<input type="checkbox"/>	<input type="checkbox"/>	<input checked="" type="checkbox"/>
Transient Testing:	<input checked="" type="checkbox"/>	<input type="checkbox"/>	<input type="checkbox"/>

#### 4. Component Specification

Component Part Number:	MOIS DSP 00
------------------------	-------------

#### 5. Facility and Equipment Checks

5.1. Calibration certificates checked and valid, recorded in the following table : Conform

5.2. All instruments are equipped with identification label : Yes

5.3. Calibration certificates are complete of calibration-chain with detailed information regarding primary used. : Yes

5.4. Is the anechoic/semi-anechoic chamber correctly set up in all its electrical/mechanical parts to ensure the validity of the measurements? : Yes



**CETOC TS**

CETOC Technical Service srl  
Via della Bufalotta, 374,  
00139 Roma

Inspection Report Nr.: CN-112-17-207-COM24-11004-IR  
Manufacturer: Shenzhen Xiaofeida Electronics Co., Ltd.  
Type: MOIS DSP 00

This inspection report shall not be reproduced except in full, without written approval of the technical service.



ISP N° 0184 E

Membro degli Accordi di Mutuo Riconoscimento  
EA, IAF e ILAC

Signatory of EA, IAF and ILAC  
Mutual Recognition Agreements

Equipment	Serial / Certificate No.	Calibration due*
ALSE ROOM	CN 2GB22052344006-0006	26/05/2025
EMI receiver	CN 2GB23062713337-0062	29/06/2024
L.I.S.N.	CN 2GB23062713337-0052	29/06/2024
L.I.S.N.	CN 2GB23062713337-0053	29/06/2024
Biconical antenna	CN 1GA23062713337-0068	05/07/2025
Log-periodic antenna	CN J202307040840-0003-G1	27/08/2024
Supply Voltage Change Simulator	CN 2GB23062713337-0036	29/06/2024
Load dump wave simulator	CN 2GB23062713337-0037	29/06/2024
Transient pulse disturbance simulator	CN 2GB23062713337-0038	29/06/2024
Current Injection Clamp	CN 2GB23062713337-0055	29/06/2024
Digital phosphor oscilloscope	CN 2GB23062713337-0043	29/06/2024

\*Specify calibrated date + (interval) or calibration due date.



CETOC TS

CETOC Technical Service srl  
Via della Bufalotta, 374,  
00139 Roma

Inspection Report Nr.: CN-112-17-207-COM24-11004-IR  
Manufacturer: Shenzhen Xiaofeida Electronics Co., Ltd.  
Type: MOIS DSP 00

This inspection report shall not be reproduced except in full, without written approval of the technical service.



ISP N° 0184 E

Membro degli Accordi di Mutuo Riconoscimento  
EA, IAF e ILAC

Signatory of EA, IAF and ILAC  
Mutual Recognition Agreements

### APPENDIX 3 – INSPECTION RESULTS

		PASS	FAIL	N/A
<b>Radiated Emissions</b>				
CISPR25, 4.5.	Measuring equipment complies with CISPR 16-1-4 (2010).	<input checked="" type="checkbox"/>	<input type="checkbox"/>	<input type="checkbox"/>
<b>Test Location</b>				
Ann 7, 3.1. Ann 7, 3.3.	Test performed in: - A.L.S.E (Absorber-lined Shielded Enclosure)* <del>- O.A.T.S (Open Area Test Site)*</del> <i>*Strikethrough, as appropriate.</i>	<input checked="" type="checkbox"/>	<input type="checkbox"/>	<input type="checkbox"/>
Ann 7, 3.3.	O.A.T.S level is a clear area, free from electromagnetic reflecting surfaces, within a circle of 15 m minimum radius.	<input type="checkbox"/>	<input type="checkbox"/>	<input checked="" type="checkbox"/>
Ann 7, 3.3.	Measuring equipment is outside 15 m minimum radius circle.	<input type="checkbox"/>	<input type="checkbox"/>	<input checked="" type="checkbox"/>
Ann 7, 3.4.	Ambient noise is at least 6 dB below reference limits, in either case.	<input checked="" type="checkbox"/>	<input type="checkbox"/>	<input type="checkbox"/>
<b>Test Arrangements</b>				
CISPR25, 4.4.2.	EUT and antenna are more than 2 m from the walls and ceiling, and 1 m from the nearest absorber material.	<input checked="" type="checkbox"/>	<input type="checkbox"/>	<input type="checkbox"/>
CISPR25, 6.1.1.	Ground plane is 900 ± 50 mm high and made from 0.5 mm thick copper, brass or galvanised steel.	<input checked="" type="checkbox"/>	<input type="checkbox"/>	<input type="checkbox"/>
CISPR25, 6.1.1.	Ground plane is at least 2,000 mm length x 1,000 mm width.	<input checked="" type="checkbox"/>	<input type="checkbox"/>	<input type="checkbox"/>
CISPR25, 6.4.2.3.	ESA and harness are supported at 50 ± 5 mm above the ground plane on low relative permittivity material.	<input checked="" type="checkbox"/>	<input type="checkbox"/>	<input type="checkbox"/>
CISPR25, 6.4.2.3.	Face of the ESA is within 200 mm ± 10 mm from the edge of the ground plane.	<input checked="" type="checkbox"/>	<input type="checkbox"/>	<input type="checkbox"/>
CISPR25, 6.4.2.4.	Length of test harness, parallel to the front of the ground plane, is 1,500 ± 75 mm and does not exceed 2,000 mm.	<input checked="" type="checkbox"/>	<input type="checkbox"/>	<input type="checkbox"/>
CISPR25, 6.4.2.4.	Long segment of test harness is located parallel to the edge of the ground plane, facing the antenna at a distance of 100 ± 10 mm from the edge.	<input checked="" type="checkbox"/>	<input type="checkbox"/>	<input type="checkbox"/>
CISPR25, 6.1.2.	Power supply is Artificial Network (AN) rated at 5 Ω/50 μH.	<input checked="" type="checkbox"/>	<input type="checkbox"/>	<input type="checkbox"/>
CISPR25, 6.1.2.	EUT is: - Remotely grounded (vehicle power return line longer than 200 mm): two artificial networks are required, one for the positive supply line and one for the power return line* <del>- Locally grounded (vehicle power return line 200 mm or shorter): one artificial network is required for the positive supply*</del> <i>*Strikethrough, as appropriate.</i>	<input checked="" type="checkbox"/>	<input type="checkbox"/>	<input type="checkbox"/>
CISPR25, 6.1.2.	Case of the ESA is: <del>- Grounded, simulating actual vehicle configuration*</del> - Not grounded, simulating actual vehicle configuration* <i>*Strikethrough, as appropriate.</i>	<input checked="" type="checkbox"/>	<input type="checkbox"/>	<input type="checkbox"/>
CISPR25, 6.1.2.	AN is electrically bonded to the ground plane.	<input checked="" type="checkbox"/>	<input type="checkbox"/>	<input type="checkbox"/>



CETOC TS

CETOC Technical Service srl  
Via della Bufalotta, 374,  
00139 Roma

Inspection Report Nr.: CN-112-17-207-COM24-11004-IR  
Manufacturer: Shenzhen Xiaofeida Electronics Co., Ltd.  
Type: MOIS DSP 00

This inspection report shall not be reproduced except in full, without written approval of the technical service.



ISP N° 0184 E

Membro degli Accordi di Mutuo Riconoscimento  
EA, IAF e ILAC

Signatory of EA, IAF and ILAC  
Mutual Recognition Agreements

**Antenna**

<i>CISPR25, 6.4.2.6.</i>	Height of the phase centre is 100 ± 10 mm above the ground plane.	<input checked="" type="checkbox"/>	<input type="checkbox"/>	<input type="checkbox"/>
<i>CISPR25, 6.4.2.6.</i>	No part of any antenna radiating element is closer than 250 mm to the floor.	<input checked="" type="checkbox"/>	<input type="checkbox"/>	<input type="checkbox"/>
<i>CISPR25, 6.4.2.6.</i>	Radiating elements of the measuring antenna are not closer than 1,000 mm to any absorber material, except that used on the floor, and are not closer than 2,000 mm to the walls or ceiling of the shielded enclosure.	<input checked="" type="checkbox"/>	<input type="checkbox"/>	<input type="checkbox"/>
<i>CISPR25, 6.4.2.6.</i>	Phase centre (for biconical) or tip (for log-periodic) is 1,000 ± 50 mm from the harness.	<input checked="" type="checkbox"/>	<input type="checkbox"/>	<input type="checkbox"/>
<i>CISPR25, 6.4.2.6.</i>	Antenna calibrated for this distance to correct measuring point (phase centre or tip).	<input checked="" type="checkbox"/>	<input type="checkbox"/>	<input type="checkbox"/>
<i>CISPR25, 6.4.2.6.</i>	Phase centre of the antenna is in line with the centre of the longitudinal part of the wiring harness.	<input checked="" type="checkbox"/>	<input type="checkbox"/>	<input type="checkbox"/>
<i>Ann 7, Ann 8, 4.3.</i>	Pre-test sweep supplied to show compliance throughout frequency range 30 to 1,000 MHz.	<input checked="" type="checkbox"/>	<input type="checkbox"/>	<input type="checkbox"/>
<i>Ann 7, Ann 8, 4.3.</i>	Test frequencies chosen from pre-test data.	<input checked="" type="checkbox"/>	<input type="checkbox"/>	<input type="checkbox"/>

**Narrowband Test Results**

<i>Ann 8, 2.</i>	Operational mode of ESA: Normal operation	<input checked="" type="checkbox"/>	<input type="checkbox"/>	<input type="checkbox"/>
<i>Ann 8, 4.2.</i>	Detector used and bandwidth: Average, 120kHz	<input checked="" type="checkbox"/>	<input type="checkbox"/>	<input type="checkbox"/>
<i>6.6.2.</i>	ESA meets narrowband emissions limits, with both vertical and horizontal polarisations.	<input checked="" type="checkbox"/>	<input type="checkbox"/>	<input type="checkbox"/>

**Broadband Test Results**

<i>Ann 7, 2.</i>	Operational mode of ESA: Normal operation	<input checked="" type="checkbox"/>	<input type="checkbox"/>	<input type="checkbox"/>
<i>Ann 7, 4.2.</i>	Detector used and bandwidth: Quasi peak, 120kHz	<input checked="" type="checkbox"/>	<input type="checkbox"/>	<input type="checkbox"/>
<i>6.5.2.</i>	ESA meets broadband emissions limits, with both vertical and horizontal polarisations.	<input checked="" type="checkbox"/>	<input type="checkbox"/>	<input type="checkbox"/>

**Radiated Immunity**

**Test Method(s) used and Frequency Range(s)**

<i>ISO11452-4</i>	BCI frequency range between 20 and 400 MHz:	<input checked="" type="checkbox"/>	<input type="checkbox"/>	<input type="checkbox"/>
<i>ISO11452-2</i>	Free field frequency range between 400 and 2,000 MHz:	<input checked="" type="checkbox"/>	<input type="checkbox"/>	<input type="checkbox"/>
<i>ISO11452-3</i>	TEM cell frequency range between 20 and 200 MHz:	<input type="checkbox"/>	<input type="checkbox"/>	<input checked="" type="checkbox"/>
<i>ISO11452-5</i>	150 mm stripline frequency range between 20 and 400 MHz:	<input type="checkbox"/>	<input type="checkbox"/>	<input checked="" type="checkbox"/>
<i>ISO11452-5</i>	800 mm stripline frequency range between 20 and 2,000 MHz:	<input type="checkbox"/>	<input type="checkbox"/>	<input checked="" type="checkbox"/>



CETOC TS

CETOC Technical Service srl  
Via della Bufalotta, 374,  
00139 Roma

Inspection Report Nr.: CN-112-17-207-COM24-11004-IR  
Manufacturer: Shenzhen Xiaofeida Electronics Co., Ltd.  
Type: MOIS DSP 00

This inspection report shall not be reproduced except in full, without written approval of the technical service.



ISP N° 0184 E

Membro degli Accordi di Mutuo Riconoscimento  
EA, IAF e ILAC

Signatory of EA, IAF and ILAC  
Mutual Recognition Agreements

Maximum frequency step sizes do not exceed:

Frequency Band (MHz)	Linear Steps (MHz)	Log Steps (%)	Actual Steps Used
20 - 200	5	5	5%
200 - 400	10	5	5%
400 - 1000	20	2	2%
1000 - 2000	40	2	2%

### Test Arrangements (General)

Ann 9, 2.2.	Operational mode of ESA: Normal operation	<input checked="" type="checkbox"/>	<input type="checkbox"/>	<input type="checkbox"/>
Ann 9, 2.3.	Extraneous equipment in place during calibration.	<input checked="" type="checkbox"/>	<input type="checkbox"/>	<input type="checkbox"/>
Ann 9, 2.4.	Test equipment used is the same as for calibration.	<input checked="" type="checkbox"/>	<input type="checkbox"/>	<input type="checkbox"/>
Ann 9, 2.5.	Loads and actuators are as realistic as possible.	<input checked="" type="checkbox"/>	<input type="checkbox"/>	<input type="checkbox"/>
Ann 9, 2.5.	Case of ESA is: - <del>Grounded, simulating actual vehicle configuration*</del> - Not grounded, simulating actual vehicle configuration* <i>*Strikethrough, as appropriate.</i>	<input checked="" type="checkbox"/>	<input type="checkbox"/>	<input type="checkbox"/>
Ann 9, 3.1.	Test frequency range is 20 to 2,000 MHz.	<input checked="" type="checkbox"/>	<input type="checkbox"/>	<input type="checkbox"/>
Ann 9, 3.1.	Test signal is R.F. sine wave amplitude, modulated by a 1 kHz sine wave at a modulation depth of $0.8 \pm 0.04$ , in the 20 - 800 MHz band and pulse modulation (time on 577 $\mu$ s, period 4,600 $\mu$ s) in the 800 - 2,000 MHz band.	<input checked="" type="checkbox"/>	<input type="checkbox"/>	<input type="checkbox"/>
6.8.2.1.	Pre-test sweep supplied to show compliance throughout frequency range 20 to 2,000 MHz.	<input checked="" type="checkbox"/>	<input type="checkbox"/>	<input type="checkbox"/>
Ann 9, 3.2.	Test frequencies chosen from pre-test data.	<input checked="" type="checkbox"/>	<input type="checkbox"/>	<input type="checkbox"/>
6.8.2.2.	No degradation of immunity related functions during the tests.	<input checked="" type="checkbox"/>	<input type="checkbox"/>	<input type="checkbox"/>

### BCI Immunity

ISO11452-4, 5.	Shielded area used: Yes	<input checked="" type="checkbox"/>	<input type="checkbox"/>	<input type="checkbox"/>
ISO11452-4, 8.3.2.1.	Forward power used to achieve specified current.	<input checked="" type="checkbox"/>	<input type="checkbox"/>	<input type="checkbox"/>

### Installation of ESA under Test

Ann 9, 4.3.2.	Current probe located $150 \pm 10$ mm from ESA connectors.	<input checked="" type="checkbox"/>	<input type="checkbox"/>	<input type="checkbox"/>
Ann 9, 4.3.2.	ESA installed: - <del>In a vehicle, as per ISO 11451-4*</del> - On a ground plane, as per ISO 11452-4* <i>*Strikethrough, as appropriate.</i>	<input checked="" type="checkbox"/>	<input type="checkbox"/>	<input type="checkbox"/>
ISO11452-4, 7.1.	Ground plane is made from at least 0.5 mm thick copper, brass or galvanised steel.	<input checked="" type="checkbox"/>	<input type="checkbox"/>	<input type="checkbox"/>
ISO11452-4, 7.1.	Minimum width of the ground plane is 1,000 mm and the minimum length is 1,500 mm, or length of the entire underneath of equipment plus 200 mm, whichever is greater.	<input checked="" type="checkbox"/>	<input type="checkbox"/>	<input type="checkbox"/>



ISO11452-4, 7.1.	Height of the ground plane is 900 ± 100 mm.	<input checked="" type="checkbox"/>	<input type="checkbox"/>	<input type="checkbox"/>
ISO11452-4, 7.1.	Ground plane is bonded to the shielded enclosure, with the straps at a distance no greater than 300 mm apart.	<input checked="" type="checkbox"/>	<input type="checkbox"/>	<input type="checkbox"/>
ISO11452-4, 7.2.	<ul style="list-style-type: none"> <li>- ESA remotely grounded (vehicle power return line longer than 200 mm): two artificial networks are required, one for the positive supply line and one for the power return line)*</li> <li>- <del>ESA locally grounded (vehicle power return line 200 mm or shorter): one artificial network is required, for the positive supply*</del></li> </ul> <p><i>*Strikethrough, as appropriate.</i></p>			
ISO11452-4, 7.2.	Power supply is Artificial Network (AN) rated at 50 Ω/5 μH.	<input checked="" type="checkbox"/>	<input type="checkbox"/>	<input type="checkbox"/>
ISO11452-4, 7.3.	ESA and harness supported 50 ± 5 mm above ground plane, on low relative permittivity material.	<input checked="" type="checkbox"/>	<input type="checkbox"/>	<input type="checkbox"/>
ISO11452-4, 7.3.	Face of the ESA within 100 mm from the edge of the ground plane.	<input checked="" type="checkbox"/>	<input type="checkbox"/>	<input type="checkbox"/>
ISO11452-4, 7.3.	Distance of at least 500 mm between ESA and any metal parts, such as the walls of the shielded enclosure (exception is ground plane).	<input checked="" type="checkbox"/>	<input type="checkbox"/>	<input type="checkbox"/>
ISO11452-4, 7.4.	Length of test harness is 1,700 + 300 mm, unless specified.	<input checked="" type="checkbox"/>	<input type="checkbox"/>	<input type="checkbox"/>

**BCI Test Results**

6.8.2.1.	No malfunction at 60 mA.	<input checked="" type="checkbox"/>	<input type="checkbox"/>	<input type="checkbox"/>
----------	--------------------------	-------------------------------------	--------------------------	--------------------------

**Free Field Immunity**

ISO11452-2, 8.3.1.	Test field defined by: <ul style="list-style-type: none"> <li>- Forward power*</li> <li>- <del>Another parameter, directly related*</del></li> </ul> <p><i>*Strikethrough, as appropriate.</i></p>	<input checked="" type="checkbox"/>	<input type="checkbox"/>	<input type="checkbox"/>
ISO11452-2, 8.3.2.	Antenna is at a distance of 1,000 ± 10 mm from the reference point.	<input checked="" type="checkbox"/>	<input type="checkbox"/>	<input type="checkbox"/>
ISO11452-2, 8.3.2.	Reference point is 150 ± 10 mm above the ground plane.	<input checked="" type="checkbox"/>	<input type="checkbox"/>	<input type="checkbox"/>
ISO11452-2, 8.3.2.	Reference point is 100 ± 10mm from the edge of the ground plane.	<input checked="" type="checkbox"/>	<input type="checkbox"/>	<input type="checkbox"/>
ISO11452-2, 8.3.2.	For frequencies from 80 - 1,000 MHz, the reference point is in the centre of the harness.	<input checked="" type="checkbox"/>	<input type="checkbox"/>	<input type="checkbox"/>
ISO11452-2, 8.3.2.	For frequencies from 1,000 - 2,000 MHz, the reference point is in line with the ESA.	<input checked="" type="checkbox"/>	<input type="checkbox"/>	<input type="checkbox"/>

**Test Arrangements**

ISO11452-2, 7.1.	Ground plane is made from at least 0.5 mm thick copper, brass or galvanised steel.	<input checked="" type="checkbox"/>	<input type="checkbox"/>	<input type="checkbox"/>
ISO11452-2, 7.1.	Minimum width of the ground plane is 1,000 mm and the minimum length is 2,000 mm.	<input checked="" type="checkbox"/>	<input type="checkbox"/>	<input type="checkbox"/>
ISO11452-2, 7.1.	Height of the ground plane is 900 ± 100 mm.	<input checked="" type="checkbox"/>	<input type="checkbox"/>	<input type="checkbox"/>



ISO11452-2, 7.1.	Bonding straps are at a distance no greater than 300 mm apart.	<input checked="" type="checkbox"/>	<input type="checkbox"/>	<input type="checkbox"/>
ISO11452-2, 7.2.	Power supply is Artificial Network (AN) rated at 50 Ω/5 μH.	<input checked="" type="checkbox"/>	<input type="checkbox"/>	<input type="checkbox"/>
ISO11452-2, 7.2.	<p>- ESA remotely grounded (vehicle power return line longer than 200 mm): two artificial networks are required, one for the positive supply line and one for the power return line)*</p> <p>- <del>ESA locally grounded (vehicle power return line 200 mm or shorter): one artificial network is required, for the positive supply*</del></p> <p>*Strikethrough, as appropriate.</p>			
ISO11452-2, 7.3.	AN mounted directly on the ground plane and cases bonded to the ground plane.	<input checked="" type="checkbox"/>	<input type="checkbox"/>	<input type="checkbox"/>
ISO11452-2, 7.3.	ESA and harness supported 50 ± 5 mm above table, on low relative permittivity material.	<input checked="" type="checkbox"/>	<input type="checkbox"/>	<input type="checkbox"/>
ISO11452-2, 7.3.	Face of the ESA located 200 ± 10 mm from the edge of the ground plane.	<input checked="" type="checkbox"/>	<input type="checkbox"/>	<input type="checkbox"/>
ISO11452-2, 7.4.	Test harness parallel to the front edge of the ground plane.	<input checked="" type="checkbox"/>	<input type="checkbox"/>	<input type="checkbox"/>
ISO11452-2, 7.4.	Total length of harness does not exceed 2,000 mm.	<input checked="" type="checkbox"/>	<input type="checkbox"/>	<input type="checkbox"/>
ISO11452-2, 7.4.	Actual wiring harness length: <input type="text" value="N/A"/> m	<input type="checkbox"/>	<input type="checkbox"/>	<input checked="" type="checkbox"/>
ISO11452-2, 7.4.	or Length is 1,500 ± 75 mm between ECU and AN.	<input checked="" type="checkbox"/>	<input type="checkbox"/>	<input type="checkbox"/>
ISO11452-2, 7.4.	Harness is at a distance of 100 ± 10 mm from the edge of the ground plane.	<input checked="" type="checkbox"/>	<input type="checkbox"/>	<input type="checkbox"/>
ISO11452-2, Fig 1	Front face of ESA is at least 1.0 m from all other conductive structures.	<input checked="" type="checkbox"/>	<input type="checkbox"/>	<input type="checkbox"/>
ISO11452-2, Fig 1	ESA harness is at least 2.0 m forward from the chamber wall.	<input checked="" type="checkbox"/>	<input type="checkbox"/>	<input type="checkbox"/>
<b>Antenna Type(s) and Frequency Range(s)</b>				
Ann 9, 4.1.2.	Antenna is vertically polarised.	<input checked="" type="checkbox"/>	<input type="checkbox"/>	<input type="checkbox"/>
ISO11452-2, 7.6.	Antenna is in the same position as the calibration.	<input checked="" type="checkbox"/>	<input type="checkbox"/>	<input type="checkbox"/>
ISO11452-2, 7.6.	Phase centre is 100 ± 10 mm above the ground plane.	<input checked="" type="checkbox"/>	<input type="checkbox"/>	<input type="checkbox"/>
ISO11452-2, 7.6.	Antenna elements are no closer than 250 mm to the floor of the facility, no closer than 0.5 m to any radio absorbent material, and no closer than 1.5 m to the wall of the facility.	<input checked="" type="checkbox"/>	<input type="checkbox"/>	<input type="checkbox"/>
ISO11452-2, 7.6.	Distance between wiring harness and antenna is 1,000 mm ± 10 mm, measured from the phase-centre of the biconical antenna, or the nearest part of the log-periodic and horn antennas.	<input checked="" type="checkbox"/>	<input type="checkbox"/>	<input type="checkbox"/>
Ann 9, 3.1.	Test signal modulation is: - AM, 1 kHz modulation, 80 % depth in 20 - 800 MHz frequency range; - PM, ton 577 μs, period 4,600 μs in 800 - 2,000 MHz frequency range.	<input checked="" type="checkbox"/>	<input type="checkbox"/>	<input type="checkbox"/>
<b>Free Field Immunity Test Results</b>				
6.8.2.	No malfunction at 30 V/m.	<input checked="" type="checkbox"/>	<input type="checkbox"/>	<input type="checkbox"/>
<b>150 mm Stripline Immunity</b>				
ISO11452-5, 5.3.1.	Stripline housed in a shielded room.	<input type="checkbox"/>	<input type="checkbox"/>	<input checked="" type="checkbox"/>



ISO11452-5, 6.2.2.	Test field defined by:	<input type="checkbox"/>	<input type="checkbox"/>	<input checked="" type="checkbox"/>
	- Forward power*			
	- Another parameter, directly related*			
	*Strikethrough, as appropriate.			
ISO11452-5, 6.2.3.	Field probe in the centre of stripline.			
<b>Installation of ESA under Test</b>				
ISO11452-5, 5.3.1.	ESA is 200 + 20 - 0 mm from the edge of the active conductor.	<input type="checkbox"/>	<input type="checkbox"/>	<input checked="" type="checkbox"/>
ISO11452-5, 5.3.1.	Peripherals are a minimum of 200 mm from the edge of the active conductor.	<input type="checkbox"/>	<input type="checkbox"/>	<input checked="" type="checkbox"/>
ISO11452-5, 5.3.1.	Harness supported 50 mm above the ground plane and is placed in the centre of the stripline.	<input type="checkbox"/>	<input type="checkbox"/>	<input checked="" type="checkbox"/>
ISO11452-5, 5.3.1.	Actual wiring harness length: <input type="text" value="N/A"/> m	<input type="checkbox"/>	<input type="checkbox"/>	<input checked="" type="checkbox"/>
	or			
	Minimum length under stripline is 1,000 mm.	<input type="checkbox"/>	<input type="checkbox"/>	<input checked="" type="checkbox"/>
ISO11452-5, 5.3.1.	All wires in the harness are terminated or open, according to the vehicle application.	<input type="checkbox"/>	<input type="checkbox"/>	<input checked="" type="checkbox"/>
ISO11452-5, 5.3.1.	Device and peripherals connected to the ground plane, as specified by the vehicle installation.	<input type="checkbox"/>	<input type="checkbox"/>	<input checked="" type="checkbox"/>
ISO11452-5, 5.3.1.	Power supply is Artificial Network (AN) rated at 50 Ω/5 μH.	<input type="checkbox"/>	<input type="checkbox"/>	<input checked="" type="checkbox"/>
ISO11452-5, 5.3.1.	- ESA remotely grounded (vehicle power return line longer than 200 mm): two artificial networks are required, one for the positive supply line and one for the power return line)*			
	<del>- ESA locally grounded (vehicle power return line 200 mm or shorter): one artificial network is required, for the positive supply*</del>			
	*Strikethrough, as appropriate.			
<b>150 mm Stripline Test Results</b>				
6.8.2.	No malfunction at 50 V/m.	<input type="checkbox"/>	<input type="checkbox"/>	<input checked="" type="checkbox"/>
<b>800 mm Stripline Immunity</b>				
Ann 9, 4.5.2.1.	Stripline housed in a screened room.	<input type="checkbox"/>	<input type="checkbox"/>	<input checked="" type="checkbox"/>
Ann 9, 4.5.2.1.	Stripline positioned a minimum of 2,000 mm from the walls or metallic enclosure.	<input type="checkbox"/>	<input type="checkbox"/>	<input checked="" type="checkbox"/>
Ann 9, 4.5.2.1.	Stripline placed on non-conducting supports at least 400 mm above the floor.	<input type="checkbox"/>	<input type="checkbox"/>	<input checked="" type="checkbox"/>
Ann 9, 4.5.2.2.	Field probe positioned within the central one-third of the longitudinal, vertical and transverse dimensions of the space between the parallel plates, with the system under test absent.	<input type="checkbox"/>	<input type="checkbox"/>	<input checked="" type="checkbox"/>
Ann 9, 4.5.2.2.	Test field defined by:	<input type="checkbox"/>	<input type="checkbox"/>	<input checked="" type="checkbox"/>
	- Forward power*			
	- Another parameter, directly related*			
	*Strikethrough, as appropriate.			



**CETOC TS**

CETOC Technical Service srl  
Via della Bufalotta, 374,  
00139 Roma

Inspection Report Nr.: CN-112-17-207-COM24-11004-IR  
Manufacturer: Shenzhen Xiaofeida Electronics Co., Ltd.  
Type: MOIS DSP 00

This inspection report shall not be reproduced except in full, without written approval of the technical service.



ISP N° 0184 E

Membro degli Accordi di Mutuo Riconoscimento  
EA, IAF e ILAC

Signatory of EA, IAF and ILAC  
Mutual Recognition Agreements

**Installation of ESA under Test**

- Ann 9, 4.5.2.3. ESA is within the central one-third of the stripline.
- Ann 9, 4.5.2.3. ESA is supported on non-conducting material.
- Ann 9, 4.5.2.4. Wiring loom is arranged as per Appendix 1, Figure 3.
- Ann 9, 4.5.2.4. Associated equipment is a minimum of 1,000 mm from stripline.

**800 mm Stripline Test Results**

Frequency Suggested (MHz)	Frequency (MHz)	Forward Power		Output Level		Field Strength (V/m)
		Cal. (w)	Test (w)	Cal. (dBm)	Test (dBm)	
N/A	N/A	N/A	N/A	N/A	N/A	N/A
N/A	N/A	N/A	N/A	N/A	N/A	N/A

- 6.8.2. No malfunction at 12.5 V/m.

**Transient Testing**

- Case of ESA is:
- ~~Grounded, simulating actual vehicle configuration\*~~
- Not grounded, simulating actual vehicle configuration\*
- \*Strikethrough, as appropriate.

**Transient Immunity**

- 6.9.1. Test set up according to ISO 7637-2 (second edition 2004 and Amd.1:2008).
- Ann 10, 2. Supply lines and other lines, which may be connected to supply lines, are tested.
- Test voltage and time parameters are within allowed envelopes.
- Test pulses and duration according to the following:

Test Pulse	Immunity Test Level	Functional Status for Systems		Test Duration
		Related to Immunity-related Functions	Not Related to Immunity-related Functions	
1	III	C	D	5000 pulses
2a	III	B	D	5000 pulses
2b	III	C	D	10 pulses
3a	III	A	D	1 hour
3b	III	A	D	1 hour
4	III	B (for ESA, which must be operational during engine start, or C, for other ESA)	D	1 pulse

- ESA operational after the tests, according to the above classification.



**CETOC TS**

CETOC Technical Service srl  
Via della Bufalotta, 374,  
00139 Roma

Inspection Report Nr.: CN-112-17-207-COM24-11004-IR  
Manufacturer: Shenzhen Xiaofeida Electronics Co., Ltd.  
Type: MOIS DSP 00

This inspection report shall not be reproduced except in full, without written approval of the technical service.



ISP N° 0184 E

Membro degli Accordi di Mutuo Riconoscimento  
EA, IAF e ILAC

Signatory of EA, IAF and ILAC  
Mutual Recognition Agreements

**Emission of Conducted Disturbances**

- 6.9.1. Test set up according to ISO 7637-2.
- Ann 10, 3. Supply lines and other lines, which may be connected to supply lines, are tested.
- Slow pulses and fast pulses tested on both powering up and powering down.

Polarity of Pulse Amplitude	Maximum Allowed Pulse Amplitude	
	Vehicles with 12 V systems	Vehicles with 24 V system
Positive	+ 75 V	+ 150 V
Negative	- 100 V	- 450 V

**Remarks**

None

Note: CETOC TS apply measurement uncertainty to calibrated items but not test results.



CETOC TS

CETOC Technical Service srl  
Via della Bufalotta, 374,  
00139 Roma

Inspection Report Nr.: CN-112-17-207-COM24-11004-IR  
Manufacturer: Shenzhen Xiaofeida Electronics Co., Ltd.  
Type: MOIS DSP 00

This inspection report shall not be reproduced except in full, without written approval of the technical service.



ISP N° 0184 E

Membro degli Accordi di Mutuo Riconoscimento  
EA, IAF e ILAC

Signatory of EA, IAF and ILAC  
Mutual Recognition Agreements

### APPENDIX 4 – TEST RESULTS

#### APPENDIX 4.1 Radiated Emissions

Vehicles with 12V systems

#### Horizontal Polarisation 30MHz to 1GHz

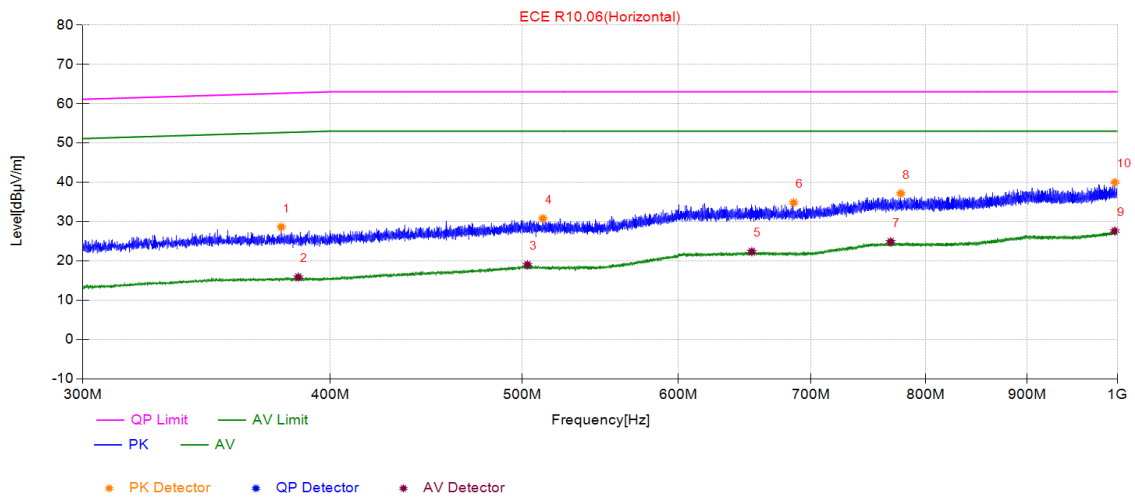
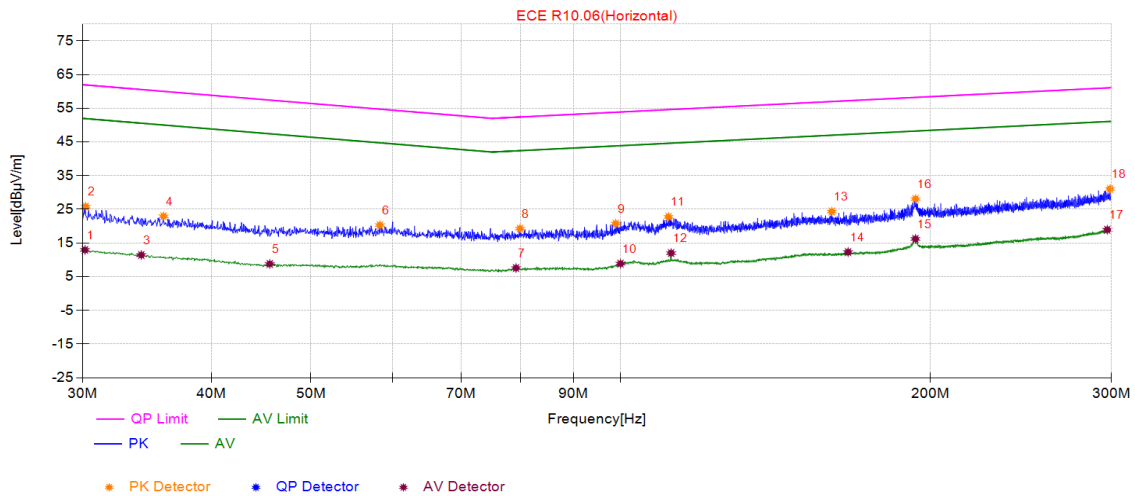



CETOC TS

CETOC Technical Service srl  
Via della Bufalotta, 374,  
00139 Roma

Inspection Report Nr.: CN-112-17-207-COM24-11004-IR  
Manufacturer: Shenzhen Xiaofeida Electronics Co., Ltd.  
Type: MOIS DSP 00

This inspection report shall not be reproduced except in full, without written approval of the technical service.



ISP N° 0184 E

Membro degli Accordi di Mutuo Riconoscimento  
EA, IAF e ILAC

Signatory of EA, IAF and ILAC  
Mutual Recognition Agreements

### Vertical Polarisation 30MHz to 1GHz

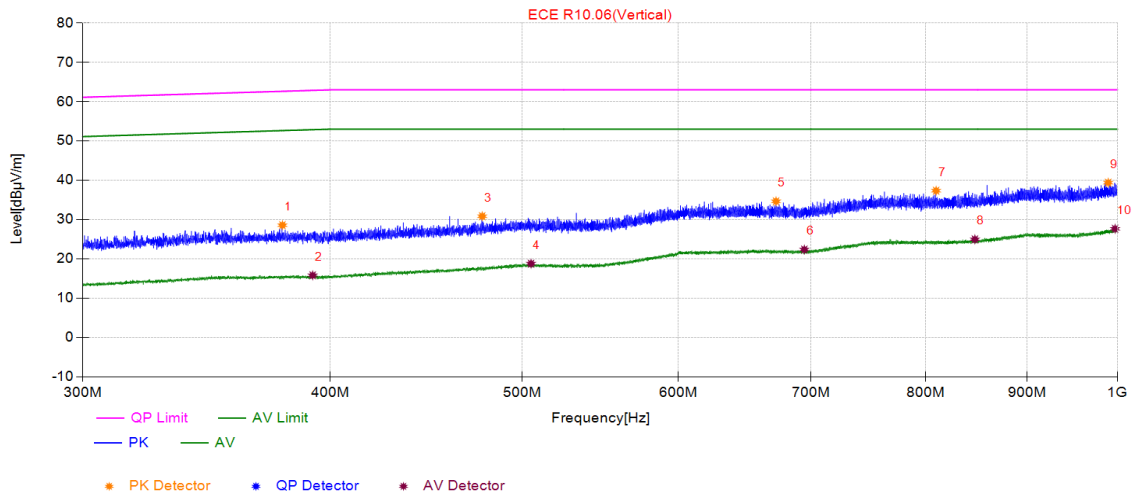
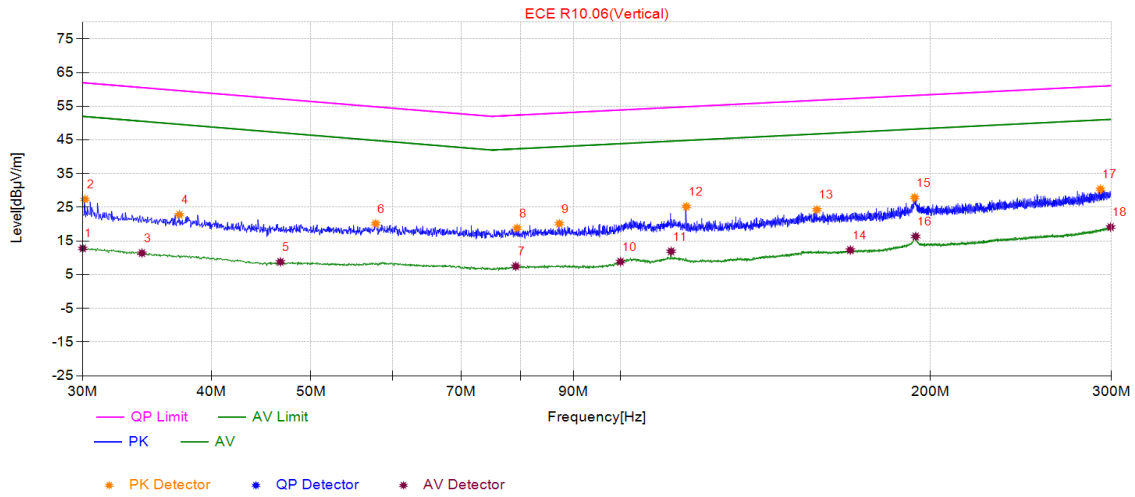



Vehicles with 24V systems

Horizontal Polarisation  
 30MHz to 1GHz

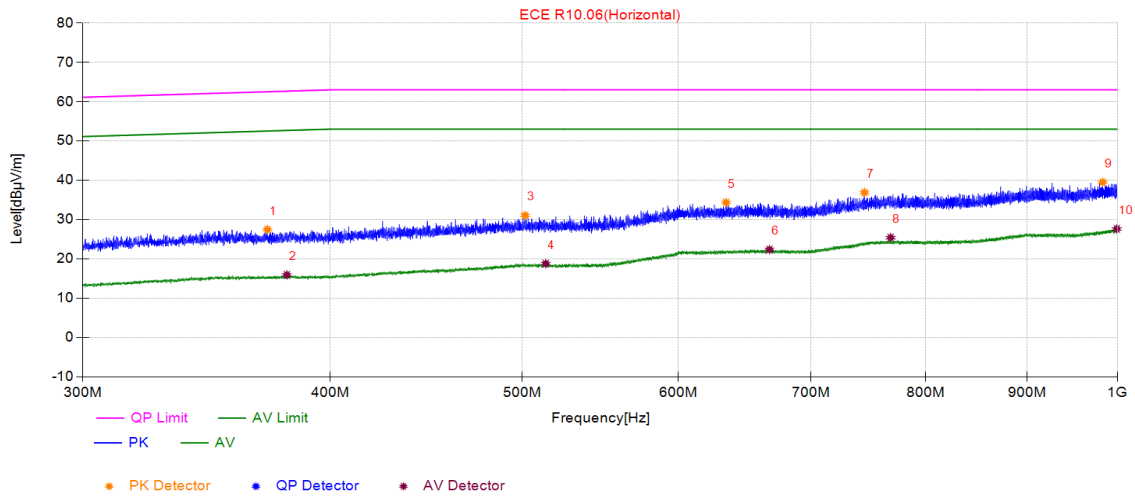
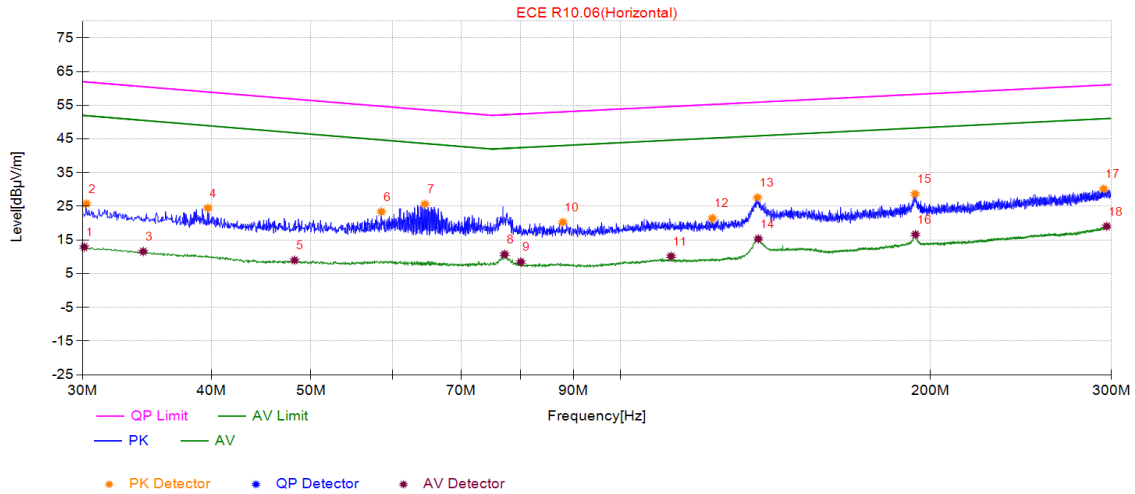



CETOC TS

CETOC Technical Service srl  
Via della Bufalotta, 374,  
00139 Roma

Inspection Report Nr.: CN-112-17-207-COM24-11004-IR  
Manufacturer: Shenzhen Xiaofeida Electronics Co., Ltd.  
Type: MOIS DSP 00

This inspection report shall not be reproduced except in full, without written approval of the technical service.



ISP N° 0184 E

Membro degli Accordi di Mutuo Riconoscimento  
EA, IAF e ILAC

Signatory of EA, IAF and ILAC  
Mutual Recognition Agreements

### Vertical Polarisation 30MHz to 1GHz

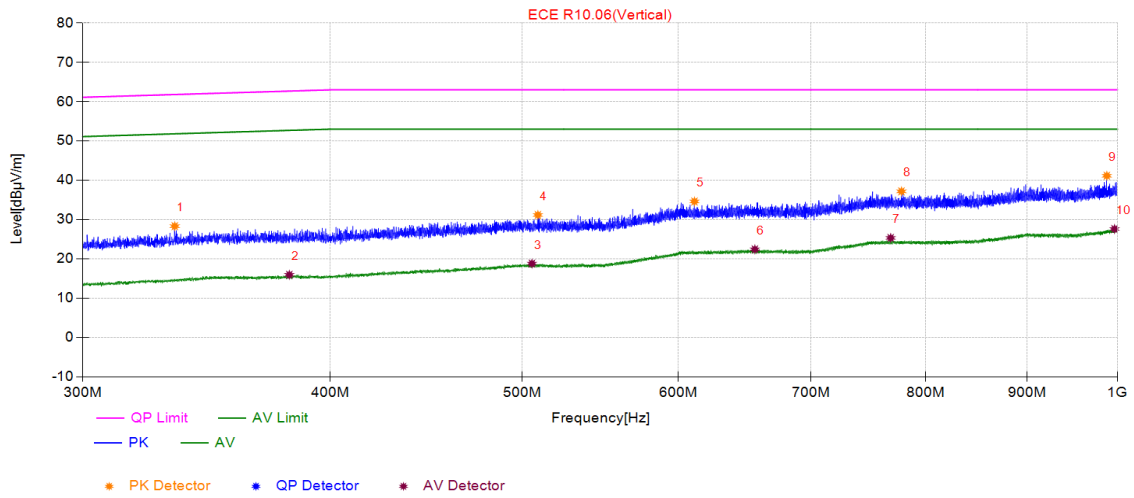
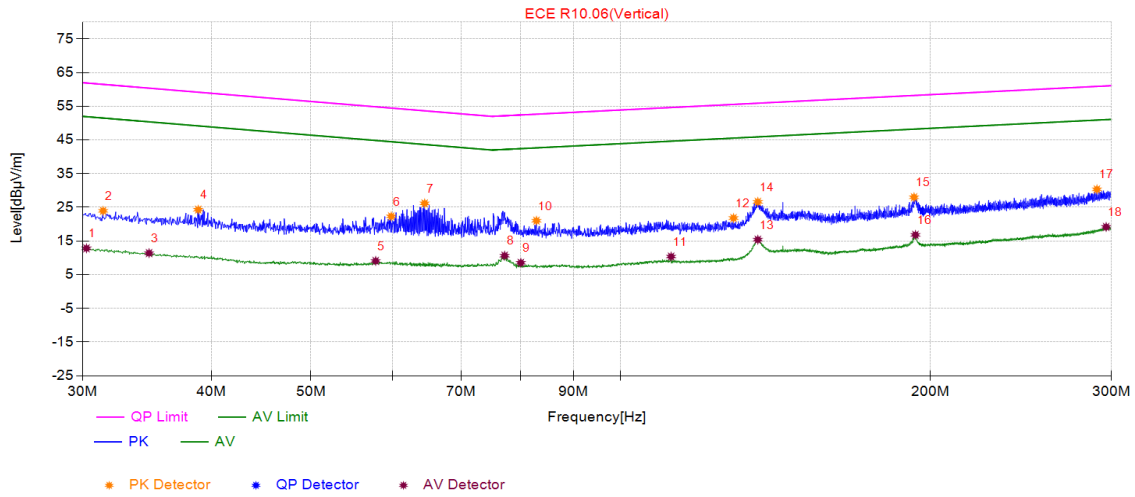



CETOC TS

CETOC Technical Service srl  
Via della Bufalotta, 374,  
00139 Roma

Inspection Report Nr.: CN-112-17-207-COM24-11004-IR  
Manufacturer: Shenzhen Xiaofeida Electronics Co., Ltd.  
Type: MOIS DSP 00

This inspection report shall not be reproduced except in full, without written approval of the technical service.



ISP N° 0184 E

Membro degli Accordi di Mutuo Riconoscimento  
EA, IAF e ILAC

Signatory of EA, IAF and ILAC  
Mutual Recognition Agreements

#### APPENDIX 4.2 Radiated Immunity

Frequency (MHz)	Level (V/m)	Modulation	Polarity	Accept Status	Test Result	
					Vehicles with 12V systems	Vehicles with 24V systems
400-800	30	AM (1kHz,80%)	V	I	A	A
800-1000	30	PM	V	I	A	A
1000-2000	30	PM	V	I	A	A

#### APPENDIX 4.3 BCI Immunity

Frequency (MHz)	Level (mA)	Modulation	Injection place	Test Result	
				Vehicles with 12V systems	Vehicles with 24V systems
20-400	60	AM (1kHz,80%)	150mm	A	A

#### APPENDIX 4.4 Transient Immunity

Test Pulse	Immunity Test Level	Functional Status for Systems		Test results	
		Related to Immunity-related Functions	Not Related to Immunity-related Functions	Vehicles with 12V systems	Vehicles with 24V systems
1	III	C	D	C	C
2a	III	B	D	A	A
2b	III	C	D	C	C
3a	III	A	D	A	A
3b	III	A	D	A	A
4	III	C	D	C	C



**APPENDIX 4.5 Emission of Conducted Disturbances**

Vehicles with 12V systems

Slow Pulse: OFF-->ON Data Graph

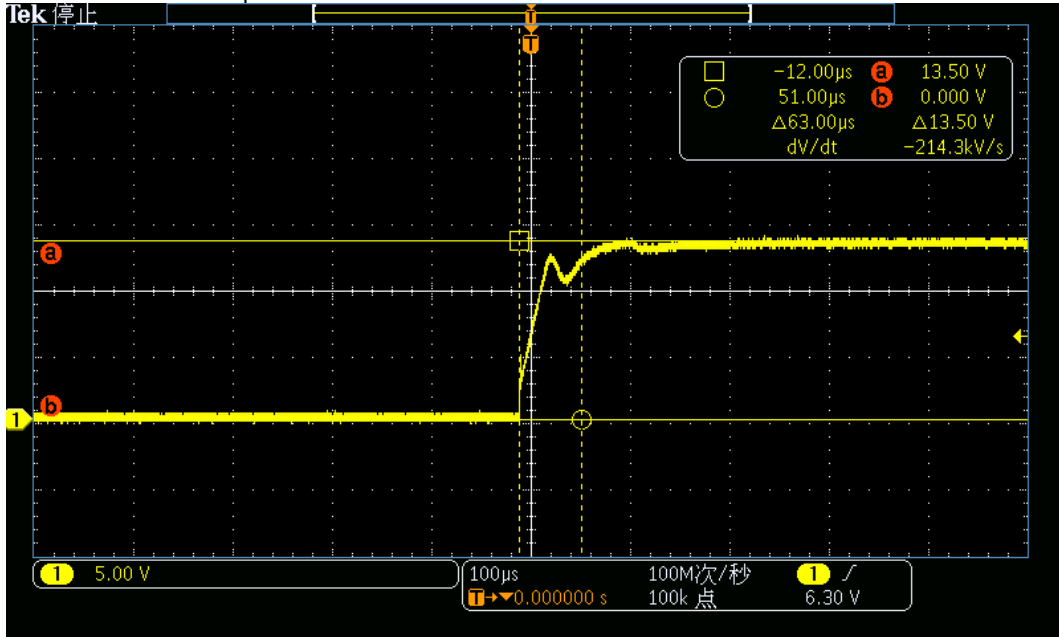

Slow Pulse: ON-->OFF Data Graph

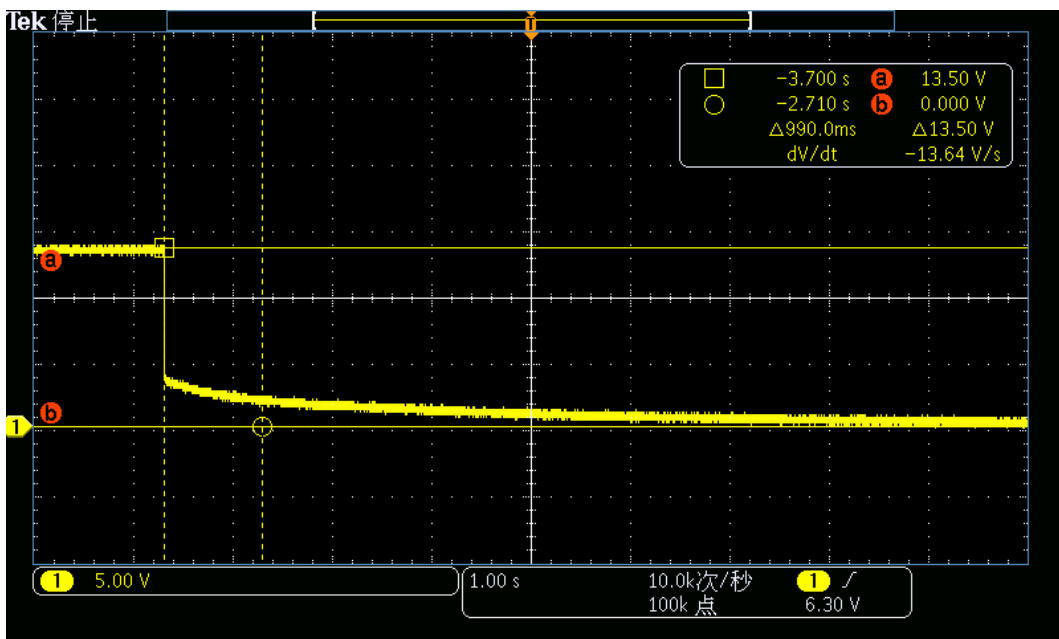



Inspection Report Nr.: CN-112-17-207-COM24-11004-IR  
 Manufacturer: Shenzhen Xiaofeida Electronics Co., Ltd.  
 Type: MOIS DSP 00



ISP N° 0184 E

Membro degli Accordi di Mutuo Riconoscimento  
 EA, IAF e ILAC

Signatory of EA, IAF and ILAC  
 Mutual Recognition Agreements

CETOC TS

CETOC Technical Service srl  
 Via della Bufalotta, 374,  
 00139 Roma

This inspection report shall not be reproduced except in full, without written approval of the technical service.

Fast Pulse: OFF-->ON Data Graph

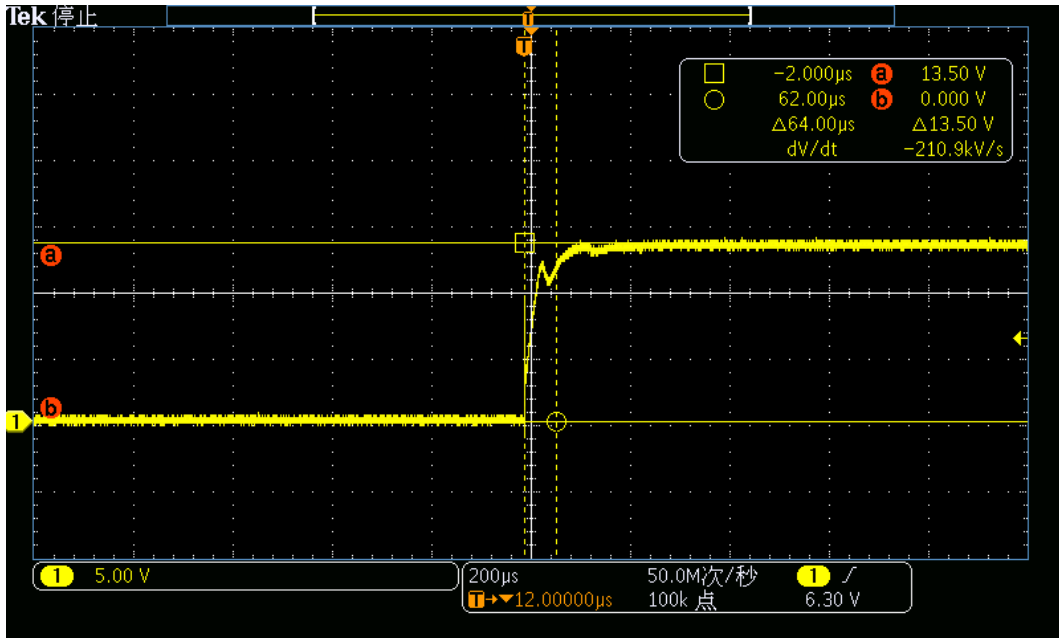

Fast Pulse: ON-->OFF Data Graph

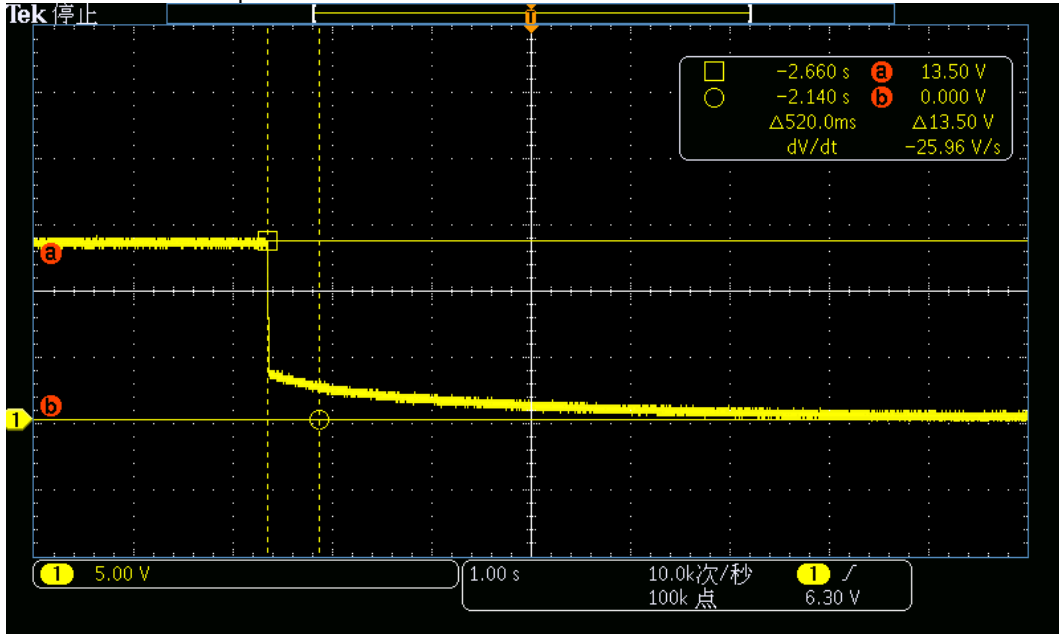



CETOC TS

CETOC Technical Service srl  
Via della Bufalotta, 374,  
00139 Roma

Inspection Report Nr.: CN-112-17-207-COM24-11004-IR  
Manufacturer: Shenzhen Xiaofeida Electronics Co., Ltd.  
Type: MOIS DSP 00

This inspection report shall not be reproduced except in full, without written approval of the technical service.



ISP N° 0184 E

Membro degli Accordi di Mutuo Riconoscimento  
EA, IAF e ILAC

Signatory of EA, IAF and ILAC  
Mutual Recognition Agreements

### Vehicles with 24V systems

Slow Pulse: OFF-->ON Data Graph

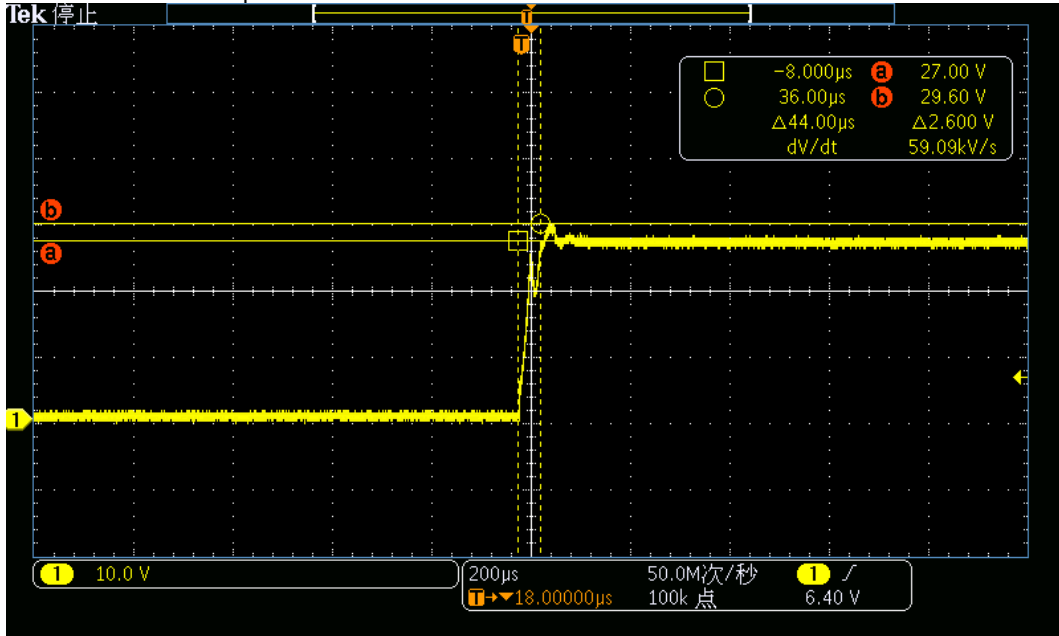

Slow Pulse: ON-->OFF Data Graph

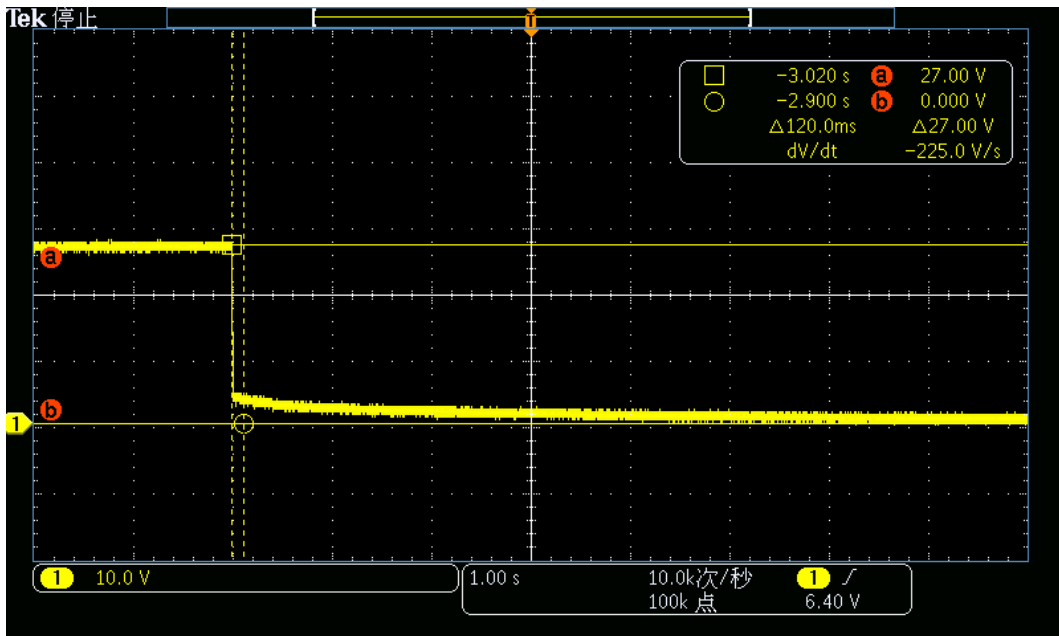



Fast Pulse: OFF-->ON Data Graph

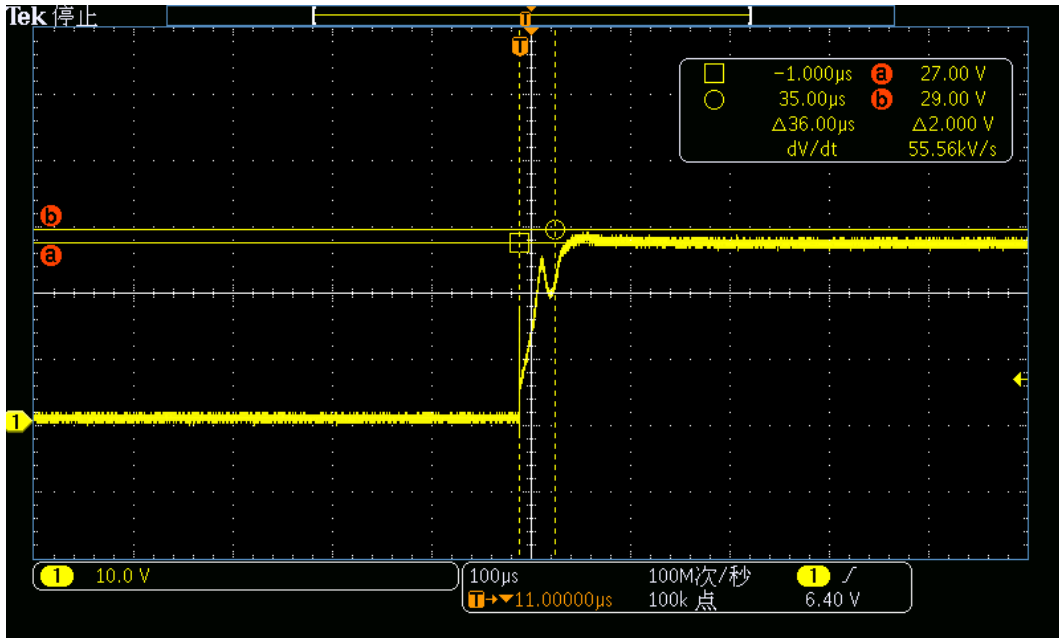

Fast Pulse: ON-->OFF Data Graph

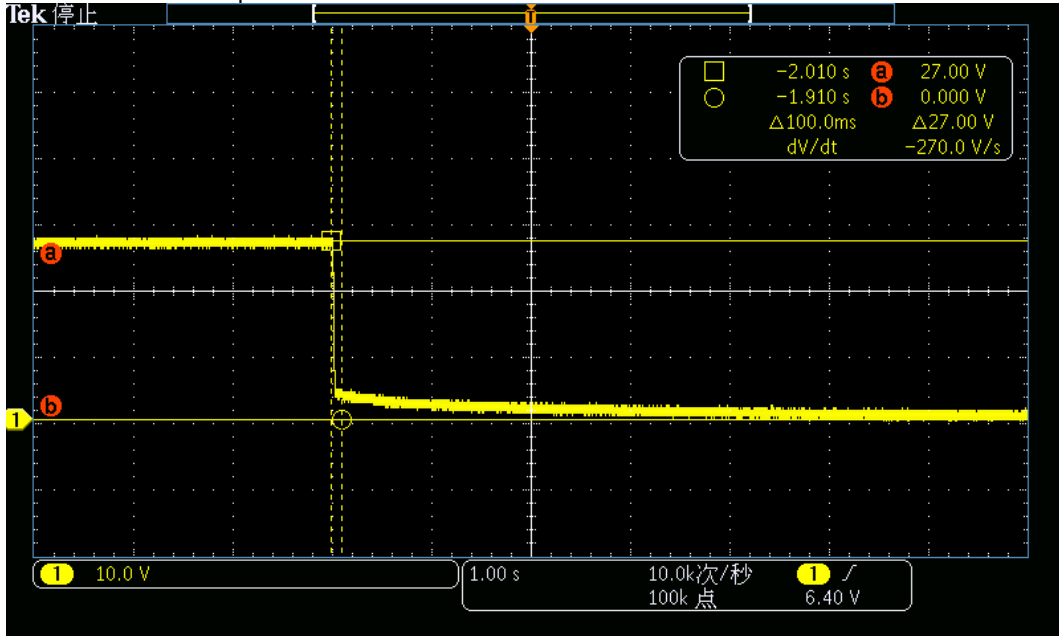

**Information document no. MOIS DSP 00-00 relating to type-approval of an  
electronic subassembly with respect to electromagnetic compatibility (ECE  
Regulation 10.06 to Supplement 2)**

Type : MOIS DSP 00

Manufacturer : Shenzhen Xiaofeida Electronics Co., Ltd.

Date : 29/01/2024

Information document No. : MOIS DSP 00-00  
Manufacturer : Shenzhen Xiaofeida Electronics Co., Ltd.  
Regulation : R10.06 to Supplement 2

---

## **INDEX**

- 2 Index
- 3 General
- 5 Drawings of the ESA
- 7 Electronic block diagram
- 8 List of components constituting the ESA

## GENERAL

1. Make (trade name of manufacturer):  
**XFD**

2. Type: **MOIS DSP 00**

**Variants: D222-V7, D222-V8**

**All variants have the same appearance, Function, PCB layout, electronic circuit design and the same component of PCB with the type, the difference among them are the model name and display effect of the different model.**

General commercial description(s):  
**MOIS Display**

3. Means of identification of type, if marked on the component/separate technical unit <sup>(1)</sup>:

**Approval mark**

3.1 Location of that marking:  
**See Drawings of the ESA.**

4. Name and address of manufacturer:

**Shenzhen Xiaofeida Electronics Co., Ltd.  
Room 901, Unit 1, Fucheng Digital Innovation Park, 15-5, Shijing Road,  
Fumin Community, Fucheng Street, Longhua District, Shenzhen City,  
Guangdong Province, China**

Name and address of authorised representative, if any:**N/A**

5. In the case of components and separate technical units, location and method of affixing of the approval mark:

**See Drawings of the ESA.**

6. Address(es) of assembly plant(s):

**Shenzhen Xiaofeida Electronics Co., Ltd.  
Room 901, Unit 1, Fucheng Digital Innovation Park, 15-5, Shijing Road,  
Fumin Community, Fucheng Street, Longhua District, Shenzhen City,  
Guangdong Province, China**

7. This ESA shall be approved as a component/~~STU~~<sup>2</sup>.

8. Any restrictions of use and conditions for fitting:  
**N/A**

9. Electrical system rated voltage:  
**DC 12V/24V, positive/negative<sup>2</sup> ground.**

Appendix 1: Description of the ESA chosen to represent the type (electronic block diagram and list of main component constituting the ESA (e.g. make and type of microprocessor, crystal, etc.).

**See electronic block diagram and list of main component constituting the ESA for details.**

Appendix 2: Relevant test report(s) supplied by the manufacturer from a test laboratory accredited to ISO 17025 and recognized by the Type Approval Authority for the purpose of drawing up the type approval certificate.

**N/A**

Only applicable for charging systems: **N/A**

10. Charger:  
**N/A**

11. Charging current:  
**N/A**

12. Maximal nominal current (in each mode if necessary) :  
**N/A**

13. Nominal charging voltage:  
**N/A**

14. Basic ESA interface functions:  
**N/A**

15. Minimum  $R_{sce}$  value (see paragraph 7.11. of this Regulation):  
**N/A**

1. If the means of identification of type contains characters not relevant to describe the component or separate technical unit types covered by this information document, such characters shall be represented in the documentation by the symbol "?" (e.g. ABC??123??).

2. Delete where not applicable.

## Drawings of the ESA

### Location of the ECE approval mark

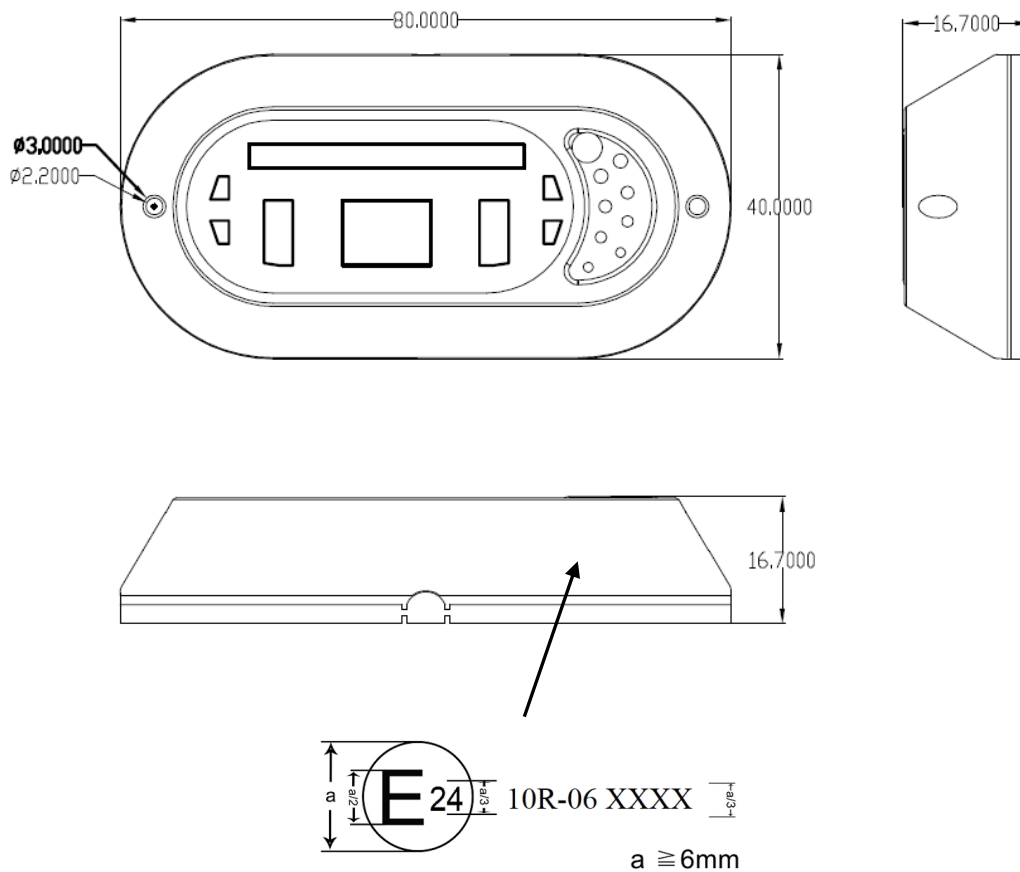

MOIS DSP 00 :



D222-V7:

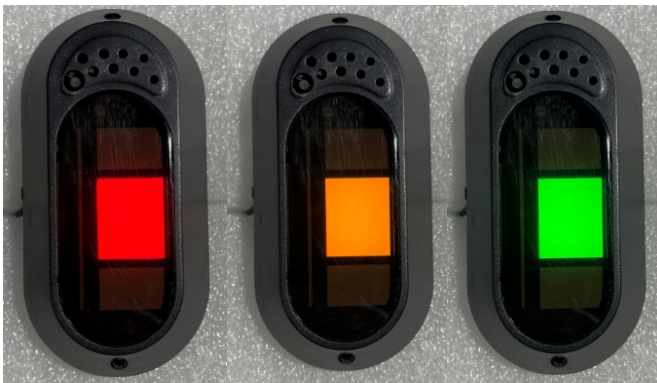

D222-V8:



### Electronic Block Diagram

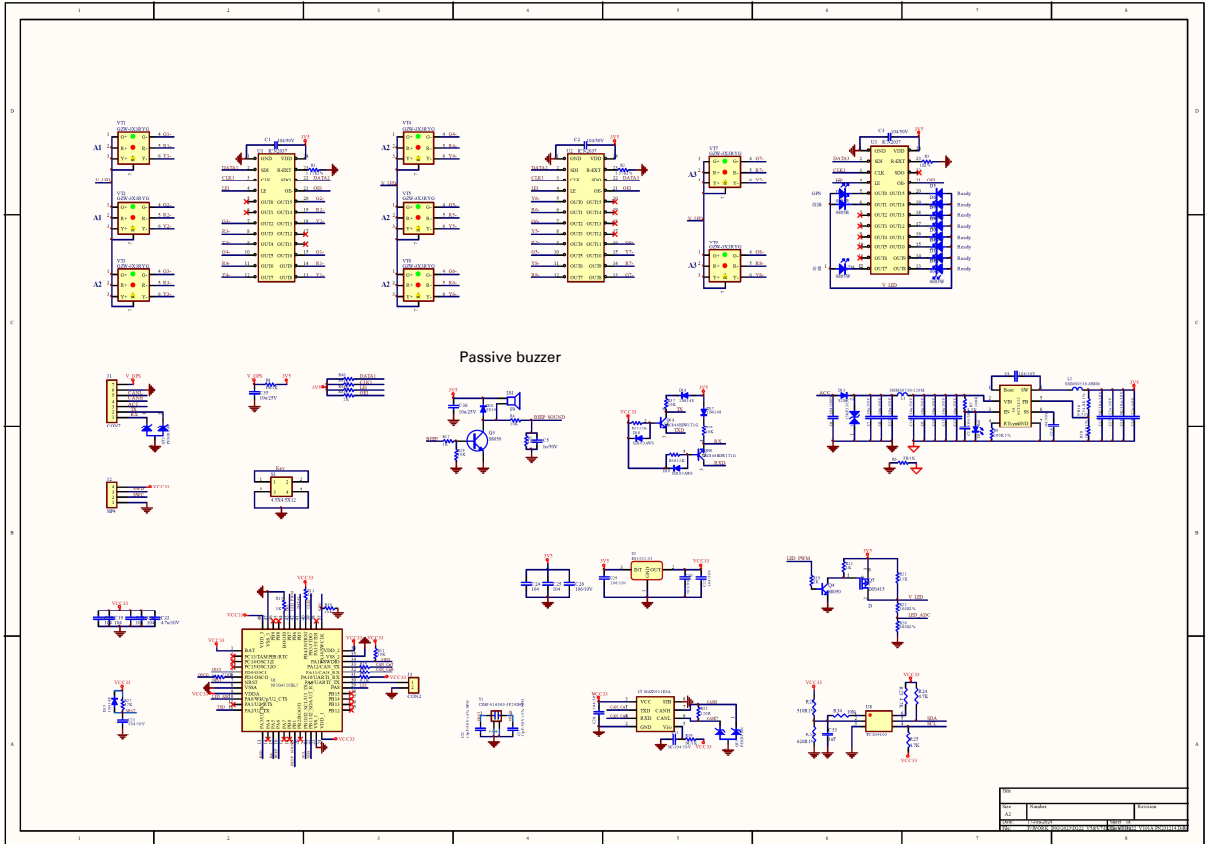

Information document No. : MOIS DSP 00-00  
Manufacturer : Shenzhen Xiaofeida Electronics Co., Ltd.  
Regulation : R10.06 to Supplement 2

---

### List of main component constituting the ESA

No.	Name	Specifications	Qty.
1	Epoxy circuit board	FR-4,T=0.8mm	1
2	Patch diode	GZW-0603W-0105	8
3	Patch diode	GZW-0805R-01096	2
4	Patch diode	GZW-0805W-0109/0805	1
5	Patch diode	GZW-3030RYG-1830/3030RYG	8
6	Patch diode	PESD1CAN	2
7	Patch diode	S2M	1
8	Patch MOS tube	DP3415	1
9	Crystal oscillator	CXAF-016000-3F20D41	1
10	Chip IC	ES5321-33	1
11	Chip IC	ICN2037	3
12	Chip IC	MAX3051ESA	1
13	Chip IC	N32G452CBL7	1
14	Chip IC	SCT2432	1
15	Chip IC	TCS34103	1
16	Plug-in diode	15KP33CA	1
17	Plug-in buzzer	Passive $\phi$ 9mm	1

**Anlage 1-5 / Annex 1-5**

*Stückliste / Partlist*

<b>Beschreibung Description</b>	<b>Modell-Nr.</b>	<b>Anzahl</b>
Radar Sensor <i>mmWave Radar</i>	ASR100	1
System-Kabel <i>System cable</i>	-	1
Display <i>Display Screen</i>	MOIS DSP 00	1
GPS&IMU <i>GPS &amp; IMU module</i>	ASI-100	1